

g

“ il signor G ispirandosi  
alla luna creò la luce ”



“ Mr. G inspired by the moon created the light ”



# ARTIERI della LUCE

handicraftsman of light





19  
59

Dal 1959, tre generazioni di imprenditori, fiduciose delle proprie risorse, hanno saputo coinvolgere una piccola ma operosa comunità dell'entroterra marchigiano per raggiungere sempre nuovi obiettivi. Questo catalogo rappresenta un'importante tappa di questa lunga esperienza artigianale made in italy e pone l'accento sull'impegno di tutto lo staff Gibas al quale vanno i più meritevoli ringraziamenti.

Since 1959, three generations of entrepreneurs, trustful in their own resources, knew to involve a small but industrious community in Le marche's outback to reach always new goals. This catalog represents an important stage of this long handicraft experience of the made in italy and puts an accent on the unquestioned engagement of all the staff Gibas to whom go the worthiest thanks.

# RICERCA & TRADIZIONE

research and tradition

Gibas da oltre sessanta anni porta sul mercato nazionale e internazionale la qualità italiana nel campo dell'illuminazione coniugando design e tradizione, affiancando l'innovazione tecnologica alla creatività artigianale. Innovazione continua ed eccellenza qualitativa sono i cardini sui quali ruota la ricerca di uno stile proprio. Il risultato è un'offerta di totale accuratezza, garantita da metodi di lavorazione che guardano alla tradizione manifatturiera italiana come unico riferimento produttivo. Il brand oggi è sinonimo di valore, movimento, provocazione, innovazione, accostamento originale, è arte fusa ad icone del quotidiano, un viaggio continuo nell'idea della bellezza.

Gibas delivers since over sixty years the italian quality in lighting to the national and international market, merging design and tradition, combining technological innovation with artisan creativity. Continuous innovation and quality excellence are the cornerstones on which rotates the search for its own style. The result is an offer of total accuracy, guaranteed by processing methods that look at the italian manufacturing tradition as a single production reference. The brand today is synonymous for value, movement, provocation, innovation, original combination, is art fused to the everyday icons, a continuous journey in the idea of beauty.



## INDEX

Agò 240  
Baja 202  
Chaplin 118  
Dolce 154  
Gilda 76  
Gioconda 196  
Gradino 160  
Inciucio 60  
Kuadra 142  
Lola 220  
Lori 126  
Luxor 134  
Moon 174  
Nio 232  
Odigiotto 54  
Osteria 214  
Polis 28  
Priamo 92  
Rail 148  
Remì 102  
Rua 208  
Rugiada 68  
Rocco 190  
Snake 38  
Spillo 84  
Titti 108  
Tuttifrutti 20  
Valencia 166  
Victoria 182  
Vitruvia 46  
Zen 10

# Image Index

## Pendant



Zen  
10-19



Tuttifrutti  
20-27



Polis  
28-37



Snake  
38-45



Vitruvia  
46-53

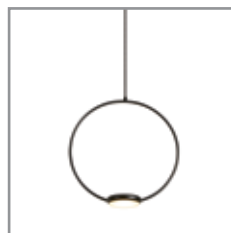

Odigiotto  
54-59

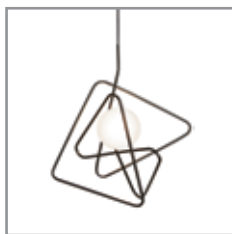

Inciucio  
60-67



Rugiada  
68-75



Gilda  
76-83



Spillo  
84-91



Priamo  
92-101



Titti  
108-117



Chaplin  
118-125



Lori  
126-133



Moon  
174-181



Victoria  
182-189



Rocco  
190-195



Gioconda  
196-201



Baja  
202-207



Rua  
208-213



Osteria  
214-219



Lola  
220-231



Nio  
232-239



Agò  
240-249

## Floor



Tuttifrutti  
20-27



Remi  
102-107



Chaplin  
118-125



Lola  
220-231

## Wall-Ceiling



Zen  
10-19



Tuttifrutti  
20-27

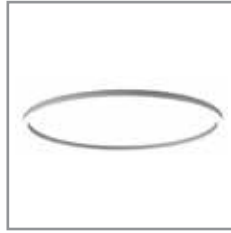

Polis  
28-37



Gilda  
76-83



Spillo  
84-91



Priamo  
92-101

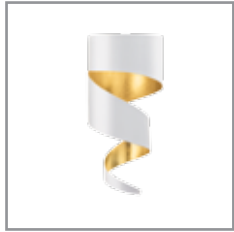

Remi  
102-107



Titti  
108-117



Luxor  
134-141



Kwadra  
142-147



Rail  
148-153



Dolce  
154-159



Gradino  
160-165



Valencia  
166-173



Moon  
174-181

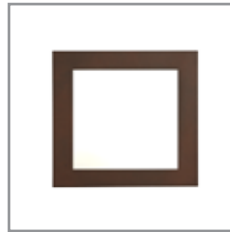

Victoria  
182-189



Rocco  
190-195



Gioconda  
196-201



Baja  
202-207



Rua  
208-213



Osteria  
214-219



Lola  
220-231



Nio  
232-239



Agò  
240-249

## Table



Tuttifrutti  
20-27



Titti  
108-117



Chaplin  
118-125



Rocco  
190-195





Zen

---

design LT DESIGN





105/29  
C84

Famiglia di lampade a sospensione e parete, realizzata con tubi in acciaio verniciato a polveri epossidiche, che si intersecano abilmente ed in maniera irregolare. Dalle estremità della struttura, le luci si diffondono attraverso diffusori bianchi in borosilicato.

Collection of suspension and wall lamps, made with steel tubes coated with epoxy powders, which intersect skillfully and in an irregular way. From the ends of the structure, the light is diffused through white borosilicate diffusers.

Kollektion von Hänge- und Wandleuchten, hergestellt aus Stahlrohren die mit Epoxidpulver beschichtet sind und sich geschickt und unregelmäßig kreuzen. Von den Enden der Struktur wird das Licht durch weiße Borosilicatstrahler verteilt.

Série de suspensions et appliques murales en tubes en acier peint en poudre époxy habilement croisés de façon irrégulière. Des diffuseurs en borosilicate blanc dirigent le flux lumineux depuis les extrémités de la structure.





---

105/22  
C84





105/42  
C27



---

105/43  
C27





---

105/43  
C27



---

105/22  
C84

---

105/21  
C27





C 27  
bronze



C 84  
coated gold

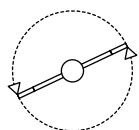
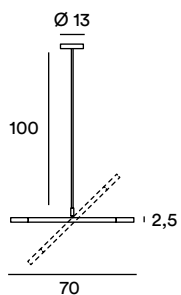

Pendant  
code  
105/22  
source  
G9 fluo/halo/led  
power  
2 x max 10W

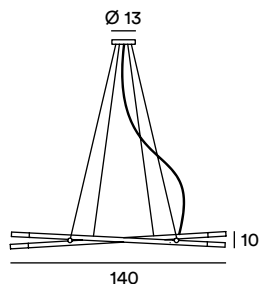
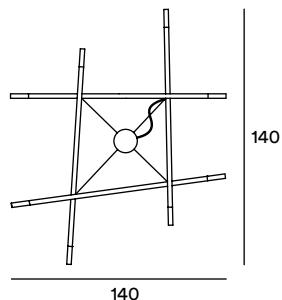

Chandelier  
code  
105/18  
source  
G9 fluo/halo/led  
power  
8 x max 10W  
cable length  
110 cm

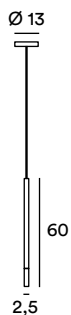

Pendant  
code  
105/21  
source  
G9 fluo/halo/led  
power  
1 x max 10W  
cable length  
150 cm

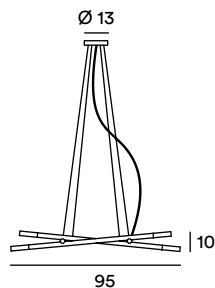
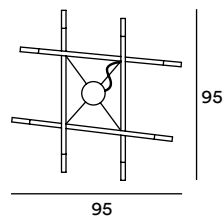

Chandelier  
code  
105/28  
source  
G9 fluo/halo/led  
power  
8 x max 10W  
cable length  
110 cm

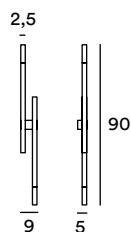

Wall  
code  
105/42  
source  
G9 fluo/halo/led  
power  
2 x max 10W

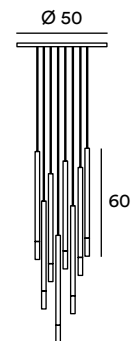

Chandelier  
code  
105/29  
source  
G9 fluo/halo/led  
power  
9 x max 10W  
cable length  
150 cm

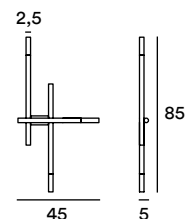

Wall  
code  
105/43  
source  
G9 fluo/halo/led  
power  
3 x max 10W

The background of the entire page is a repeating pattern of stylized fruit on shelves. The pattern consists of vertical lines representing shelves, with various combinations of circles (representing fruit) placed on them. The colors are a light, warm orange. The text is centered over this pattern.

# Tuttifrutti

---

design Davide Negri

---

106/19  
C84



---

106/66  
C74

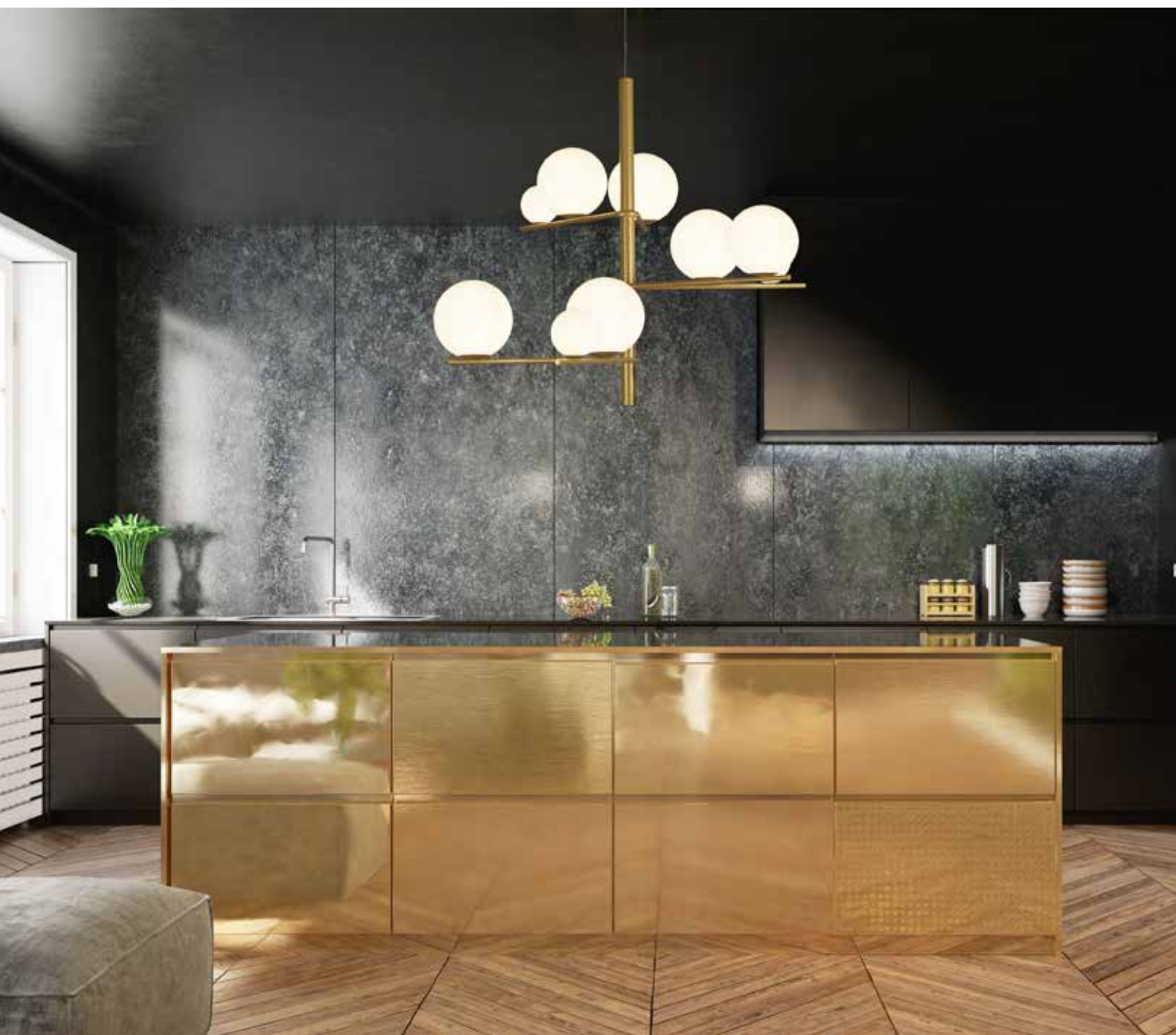

106/19  
C84

Famiglia di lampade realizzata in tubo di acciaio verniciato a polveri epossidiche e da diffusori in vetro soffiato satinato bianco.

Collection of lamps made of epoxy powder coated steel tube and white satin blown glass diffusers.

Lampenkollektion aus pulverbeschichtetem Stahlrohr und Diffusoren aus geblasenem Glas.

Série de lampes en tubes en acier peint en poudre époxy, composées de diffuseurs en verre soufflé satiné blanc.





106/42  
C80









---

106/74  
C74



---

106/42  
C80

---

106/76  
C84



-  C 74  
sand black
-  C 80  
sand white
-  C 84  
coated gold

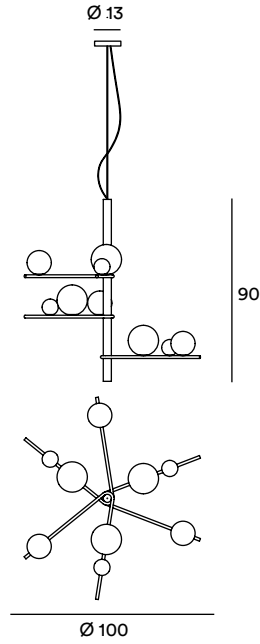

Chandelier  
code  
106/19  
source  
E14 halo/led  
power  
9 x max 33W  
cable lenght  
110 cm

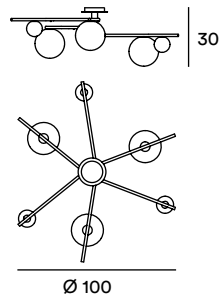

Ceiling  
code  
106/76  
source  
E14 halo/led  
power  
6 x max 33W

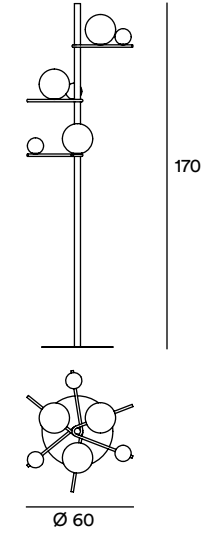

Floor  
code  
106/66  
source  
E14 halo/led  
power  
6 x max 33W

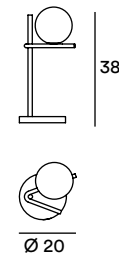
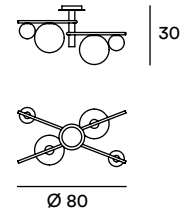
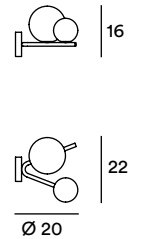

Table  
code  
106/31  
source  
E14 halo/led  
power  
1 x max 33W



Ceiling  
code  
106/74  
source  
E14 halo/led  
power  
4 x max 33W



Wall  
code  
106/42  
source  
E14 halo/led  
power  
2 x max 33W

# Polis

---

design Studio Gibas



204/40  
C1



Famiglia di lampade realizzata in lastra di acciaio verniciata a polveri epossidiche e da un diffusore in metacrilato opalino. Con doppia emissione di luce in una versione.

Collection of lamps made of epoxy powder coated steel plate and an opal methacrylate diffuser. One version has double light emission.

Lampenkollektion aus pulverbeschichtetem Stahlblech und Diffusor aus opalem Methacrylat. Eine Version hat doppelte Lichtemission.

Série de lampes réalisées en plaque en acier peint en poudre époxy, composées d'un diffuseur en méthacrylate opale. Double émission du flux lumineux disponible en une version.



204/70-77  
C1



---

204/10-17  
C36







204/15  
C36



204/15  
C36



 C 1  
white opaque

 C 36  
corten

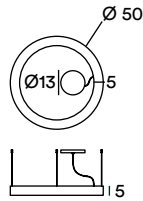

Pendant single-emission  
code  
204/15  
source/power  
36W LED 4000 Lm 2700K IP40  
dimnable  
cable lenght  
300 cm

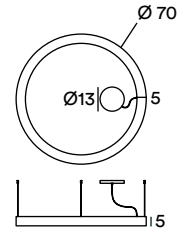

Pendant single-emission  
code  
204/17  
source/power  
54W LED 6000 Lm 2700K IP40  
dimnable  
cable lenght  
300 cm

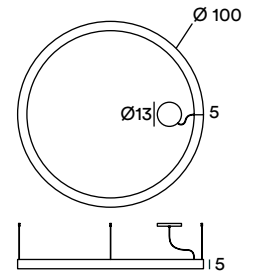

Pendant single-emission  
code  
204/10  
source/power  
81W LED 9000 Lm 2700K IP40  
dimnable  
cable lenght  
300 cm

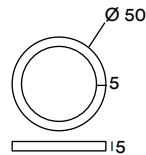

Wall-Ceiling single-emission  
code  
204/45  
source/power  
36W LED 4000 Lm 2700K IP40  
dimnable

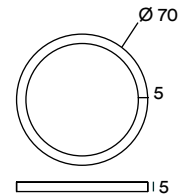

Wall-Ceiling single-emission  
code  
204/47  
source/power  
54W LED 6000 Lm 2700K IP40  
dimnable

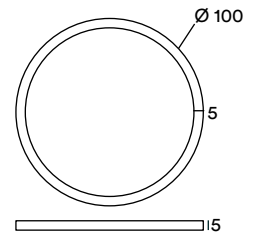

Wall-Ceiling single-emission  
code  
204/40  
source/power  
81W LED 9000 Lm 2700K IP40  
dimnable

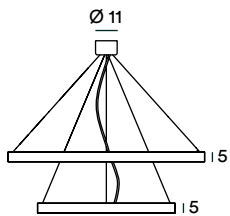
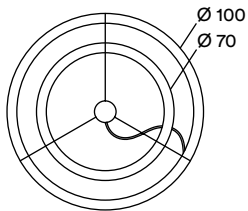

Pendant single-emission  
code  
204/19  
source/power  
135W LED 15000 Lm 2700K IP40  
dimnable  
cable lenght  
300 cm

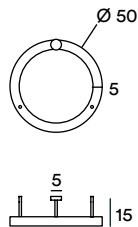

Wall-Ceiling single-emission  
code  
204/75  
source/power (indirect light)  
36W LED 4000 Lm 2700K IP40  
dimnable

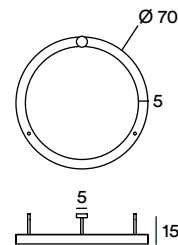

Wall-Ceiling single-emission  
code  
204/77  
source/power (indirect light)  
54W LED 6000 Lm 2700K IP40  
dimnable

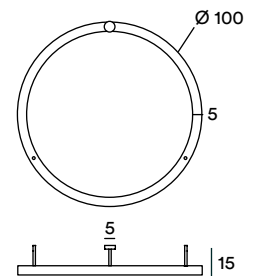

Wall-Ceiling single-emission  
code  
204/70  
source/power (indirect light)  
81W LED 9000 Lm 2700K IP40  
dimnable

204/25  
C36



204/25  
C36



204/25  
C36





C 1  
white opaque



C 36  
corten

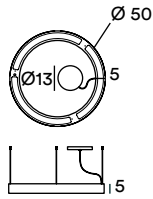

Pendant double-emission  
code  
204/25  
source/power  
36W LED 4000 Lm 2700K IP40  
dimnable  
cable lenght  
300 cm

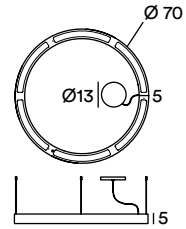

Pendant double-emission  
code  
204/27  
source/power  
54W LED 6000 Lm 2700K IP40  
dimnable  
cable lenght  
300 cm

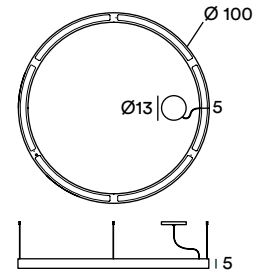

Pendant double-emission  
code  
204/20  
source/power  
81W LED 9000 Lm 2700K IP40  
dimnable  
cable lenght  
300 cm

# Snake

---

design Studio Gibas





110/12  
C36

Famiglia di lampade a sospensione in lamiera d'acciaio tagliata a laser e sagomata, verniciata a polveri epossidiche. Diffusore in metacrilato opalino superiore ed inferiore per la doppia emissione di luce.  
La modularità della collezione permette l'utilizzo in ambienti diversi.

Collection of pendant lights in laser cut and shaped sheet steel, coated with epoxy powders. Upper and lower opal methacrylate diffuser for double light emission.  
The modularity of the collection allows its use in different environments.

Kollektion von Hängeleuchten aus lasergeschnittenem und geformtem Stahlblech, beschichtet mit Epoxidpulver. Oberer und unterer Opalmethacrylat-Diffusor für doppelte Lichtemission.  
Die Modularität der Kollektion ermöglicht ihren Einsatz in verschiedenen Umgebungen.

Série de suspensions en plaque en acier découpée au laser et profilée, peinte en poudre époxy. Diffuseur en méthacrylate opale supérieur et inférieur pour une double émission du flux lumineux. La modularité de la collection permet une utilisation dans différents environnements.



---

110/18  
C36





110/21-28  
C1





---

110/21  
C1



---

110/11  
C36

---

110/28  
C1



 C 1  
white opaque

 C 36  
corten

### Composition

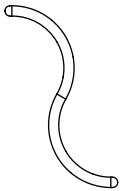

110/12

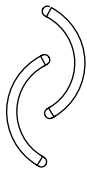

2 x 110/11

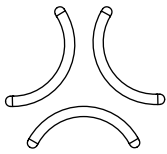

3 x 110/11

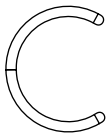

110/13

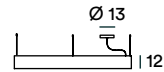
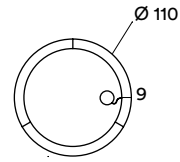

Pendant double-emission  
code  
110/21  
source/power  
81W LED 9000 Lm 2700K  
dimnable  
cable lenght  
300 cm

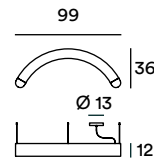

Pendant double-emission  
code  
110/11  
source/power  
27W LED 3000 Lm 2700K  
dimnable  
cable lenght  
300 cm

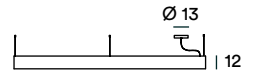
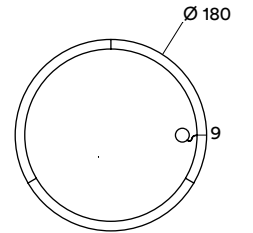

Pendant double-emission  
code  
110/28  
source/power  
135W LED 15000 Lm 2700K  
dimnable  
cable lenght  
300 cm

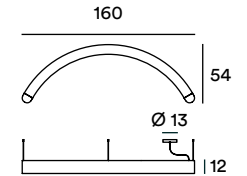

Pendant double-emission  
code  
110/18  
source/power  
45W LED 5000 Lm 2700K  
dimnable  
cable lenght  
300 cm

# Vitruvia

---

design Roberto Giacomucci





---

202/17  
C74



---

202/19  
C84

Famiglia di lampade a sospensione in diverse dimensioni e luci in tubo di acciaio verniciato a polveri epossidiche.

I diffusori ai vertici dei moduli geometrici sono in borosilicato satinato.

Collection of pendant lamps with different dimensions and lights in tubular powder coated steel. The diffusers at the top of the geometrical forms are in satin borosilicate.

Kollektion von Pendelleuchten aus pulverbeschichtetem Metallrohr mit unterschiedlichen Abmessungen. Die Strahler an der Oberseite der geometrischen Formen sind aus satiniertem Borosilikatglas.

Série de suspensions de différentes dimensions et lumières en tube en acier peint en poudre époxy. Diffuseurs dans la partie supérieure des formes géométriques en borosilicate satiné.







---

202/15  
C80



---

202/21  
C80



---

202/19  
C84





---

202/17  
C74

---

202/21  
C74



-  C 74  
sand black
-  C 80  
sand white
-  C 84  
coated gold

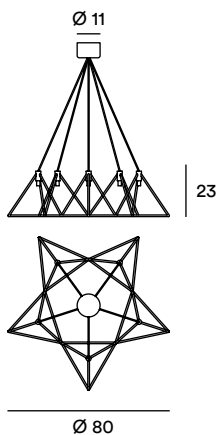

Pendant  
code  
202/15  
source  
G9 halo/led  
power  
5 x max 10W  
cable length  
150 cm

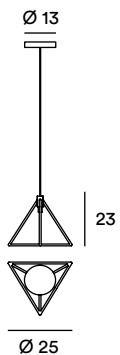

Pendant  
code  
202/21  
source  
G9 halo/led  
power  
1 x max 10W  
cable length  
150 cm

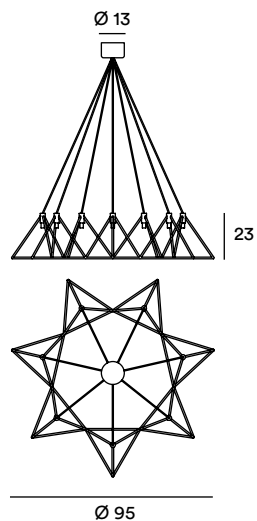

Pendant  
code  
202/17  
source  
G9 halo/led  
power  
7 x max 10W  
cable length  
150 cm

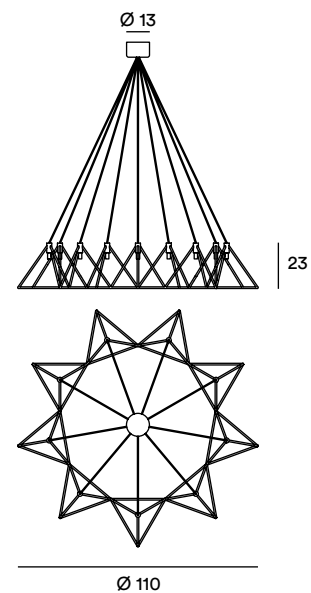

Pendant  
code  
202/19  
source  
G9 halo/led  
power  
9 x max 10W  
cable length  
150 cm

# Odigiotto

---

design Roberto Giacomucci





Famiglia di lampade a sospensione in tubo e lastra d'acciaio verniciati a polveri epossidiche. Diffusore superiore ed inferiore in metacrilato satinato per la doppia emissione di luce.

Collection of pendant lamps in tube and plate steel powder coated. Upper and lower diffuser in satin methacrylate for a dual light emission.

Kollektion von Hängeleuchten aus pulverbeschichtetem Rohr- und Stahlblech. Der Diffuser nach oben und unten in satiniertem Methacrylat sorgt für beidseitige Lichtemission.

Série de suspensions en tube et plaque en acier peint en poudre époxy. Diffuseur supérieur et inférieur en méthacrylate satiné pour une double émission du flux lumineux.

---

200/23  
C84

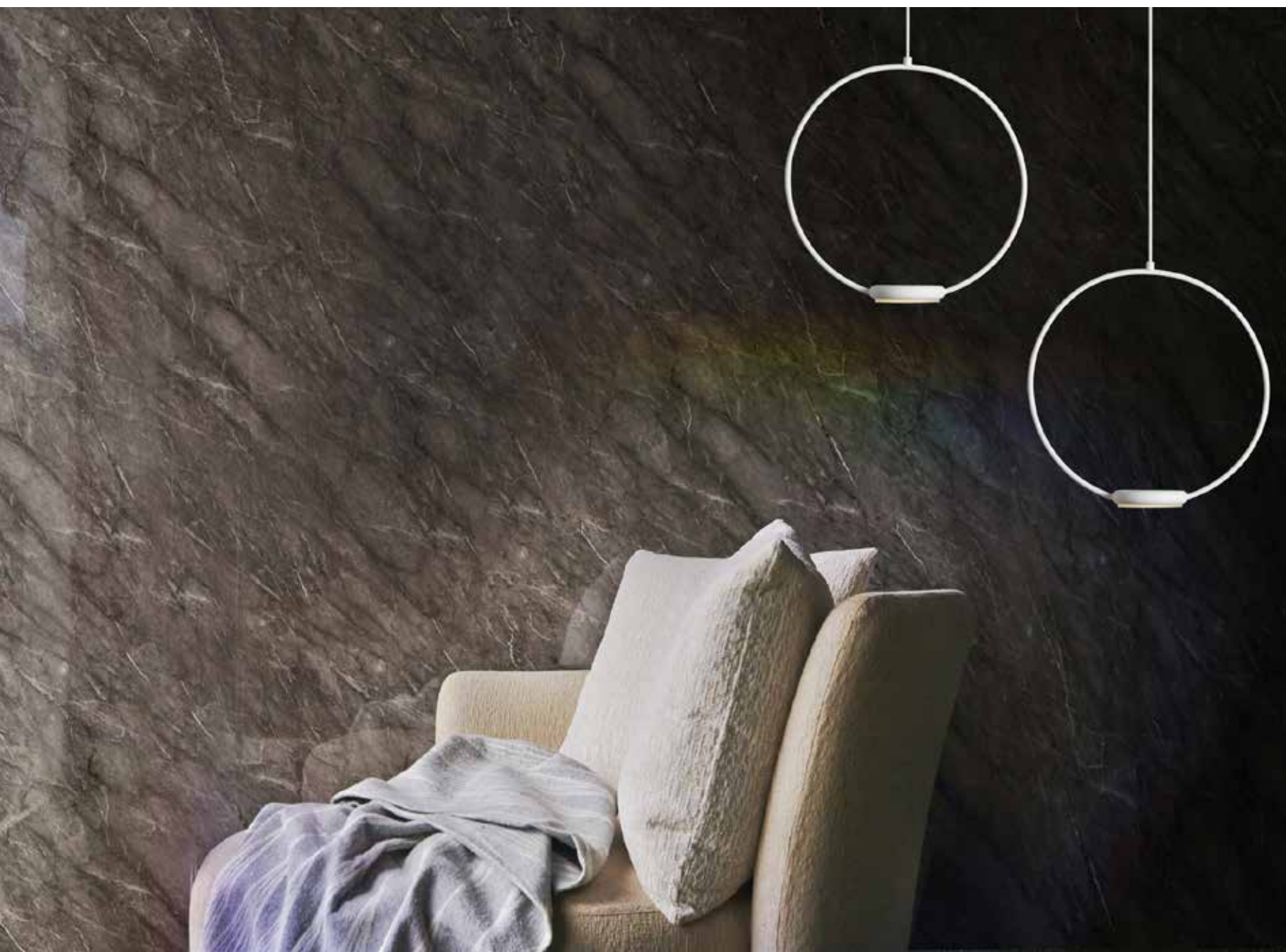





200/21  
C74



200/21  
C74



-  C 74  
sand black
-  C 80  
sand white
-  C 84  
coated gold

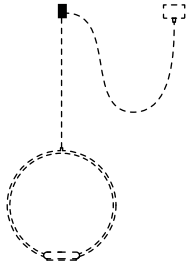

Accessory  
code  
200/d  
support for decentralization

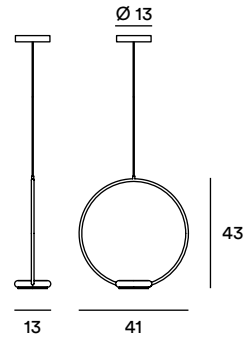

Pendant  
code  
200/21  
source  
led board  
power  
1 × 8W  
luminous flux  
600 Lm  
CCT  
2700K  
cable lenght  
150 cm

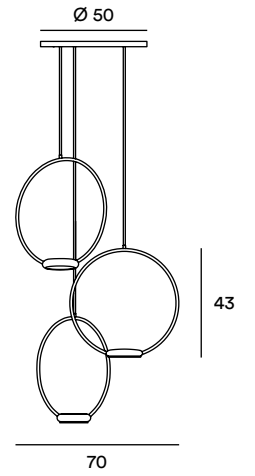

Pendant  
code  
200/23  
source  
led board  
power  
3 × 8W  
luminous flux  
1800 Lm  
CCT  
2700K  
cable lenght  
150 cm

# Inciucio

---

design Roberto Giacomucci



---

201/23  
C84



201/21  
C80

Famiglia di lampade a sospensione in acciaio verniciato a polveri epossidiche. La struttura metallica sagomata descrive curve che racchiudono il diffusore in vetro soffiato satinato bianco.

Collection of pendant lamps in powder coated steel. The curved steel pipe encloses the borosilicate white diffuser.

Kollektion von Hängeleuchten aus pulverbeschichtetem Stahl. Das Stahlrohr beschreibt Kurven die den weißen Borosilikatglas-Diffusor umschließen.

Série de suspensions en acier peint en poudre époxy. La structure en métal profilé décrit des courbes qui englobent le diffuseur en verre soufflé satiné blanc.







201/21  
C80

201/26  
C84







---

201/21  
C80

---

201/21  
C74



 C 74  
sand black

 C 80  
sand white

 C 84  
coated gold

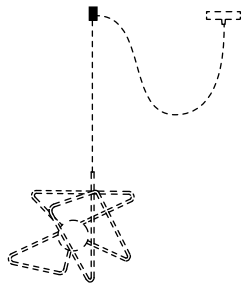

#### Accessory

code  
201/d  
support for decentralization

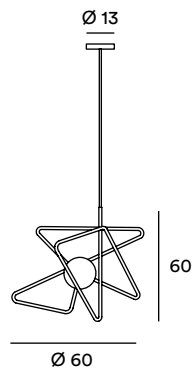

Pendant  
code  
201/21  
source  
E27 halo/led  
power  
1 x max 53W  
cable lenght  
150 cm

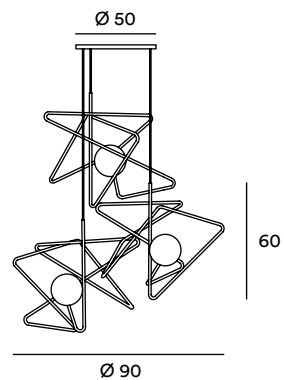

Pendant  
code  
201/23  
source  
E27 halo/led  
power  
3 x max 53W  
cable lenght  
150 cm

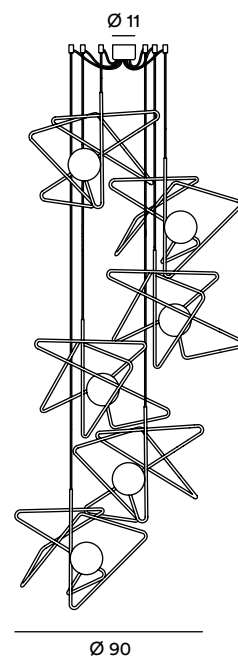

Pendant  
code  
201/26  
source  
E27 halo/led  
power  
6 x max 53W  
cable lenght  
150 cm



# Rugiada

---

design Studio Gibas



---

122/24  
C74



---

122/26  
C35



122/26  
C35+C1

Famiglia di lampade a sospensione bicolore in lastra di acciaio verniciata a polveri epossidiche e decorata a mano.

Hanging lamp in two-tone powder coated steel and decorated by hand.

Hängelampe in zweifarbig pulverbeschichtetem Metall und von Hand verziert.

Série de suspensions bicolores en plaque en acier peint en poudre époxy et décoré main.

122/25  
C36+C1





122/24  
C74+C60



122/28  
C35+C1







---

122/25  
C35



---

122/25  
C36

---

122/28  
C74+C60





C 35  
concrete



C 36  
corten



C 74  
sand black



C 1  
white opaque (inside)



C 60  
goldfoil (inside)

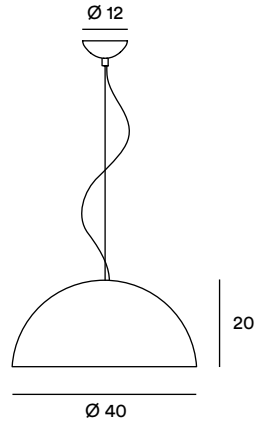

Pendant  
code  
122/24  
source  
E27 fluo/halo/led  
power  
1 x max 53W  
cable lenght  
110 cm

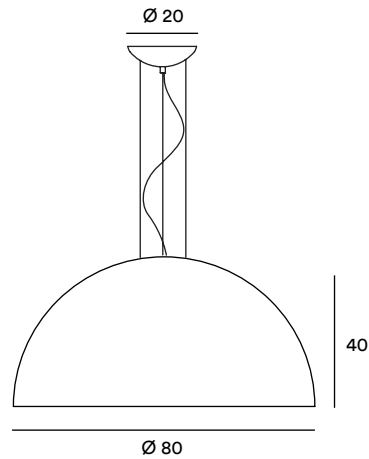

Pendant  
code  
122/28  
source  
E27 fluo/halo/led  
power  
1 x max 53W  
cable lenght  
110 cm

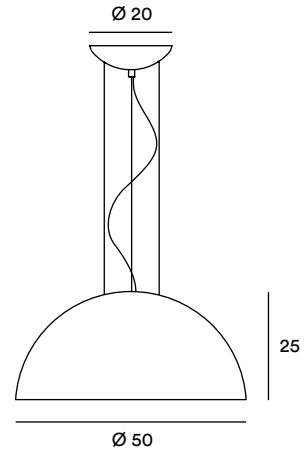

Pendant  
code  
122/25  
source  
E27 fluo/halo/led  
power  
1 x max 53W  
cable lenght  
110 cm

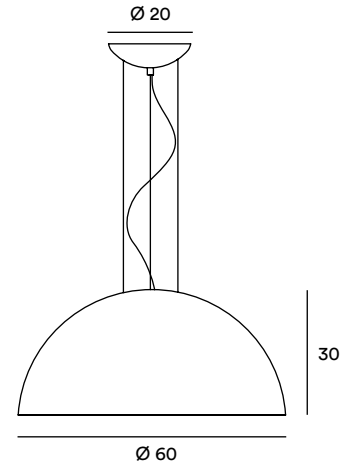

Pendant  
code  
122/26  
source  
E27 fluo/halo/led  
power  
1 x max 53W  
cable lenght  
110 cm

# Gilda

---

design Giulio Giacomozzi





Famiglia di lampade da soffitto, sospensione e applique, disponibile in diverse dimensioni. Realizzata con bracci sagomati in acciaio verniciati a polveri epossidiche e sfere in vetro soffiato fumé.

Collection of ceiling lamps, suspension lamps and wall lamps, available in different sizes. Made with shaped steel brackets coated with epoxy powders and blown smoked glass spheres.

Kollektion von Decken-, Hänge- und Wandlampen in verschiedenen Größen erhältlich. Hergestellt mit geformten Stahlarmen die mit Epoxidpuder beschichtet sind und geblasenen Rauchglaskugeln.

Série de plafonniers, suspensions et appliques disponibles en plusieurs dimensions, réalisés avec des bras en acier peint en poudre époxy et profilés, et des sphères en verre soufflé fumé.

---

210/77  
C2



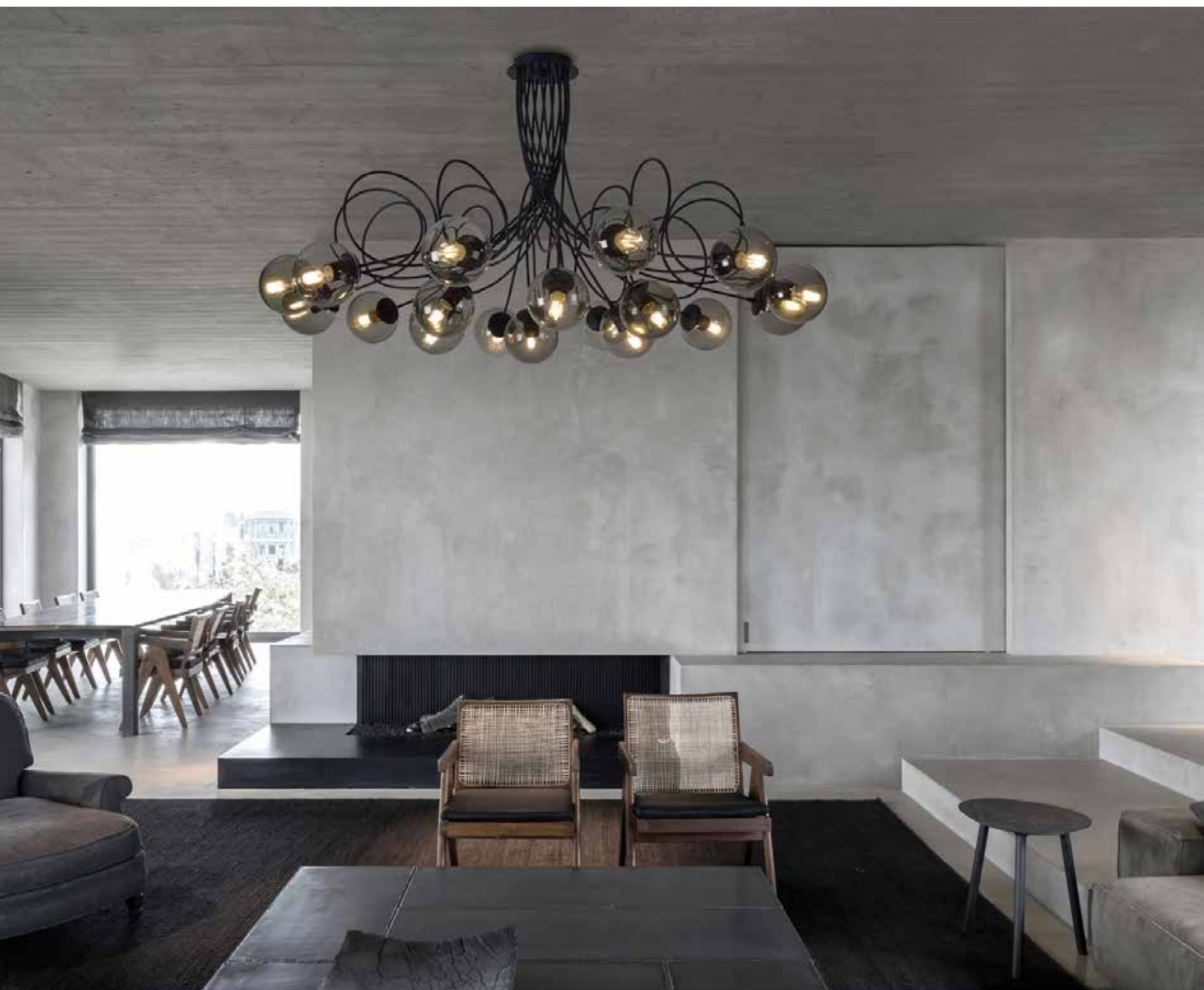



210/41  
C2



---

210/21  
C2





210/21  
C2



210/76  
C2





C 2  
black opaque

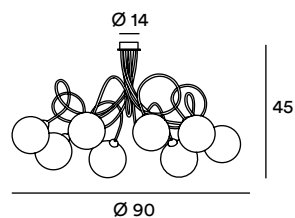

Ceiling  
code  
210/76  
source  
E27 fluo/halo/led  
power  
8 x max 53W

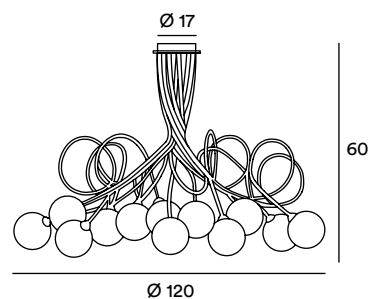

Ceiling  
code  
210/77  
source  
E27 fluo/halo/led  
power  
12 x max 53W

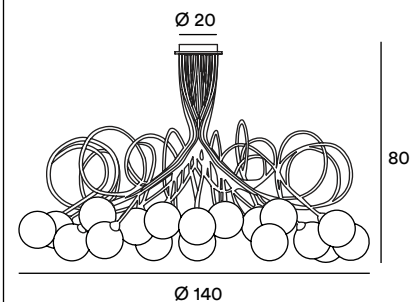

Ceiling  
code  
210/78  
source  
E27 fluo/halo/led  
power  
18 x max 53W

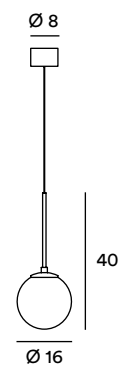

Pendant  
code  
210/21  
source  
E27 fluo/halo/led  
power  
1 x max 53W  
cable lenght  
100 cm

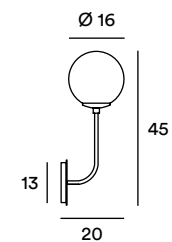

Wall  
code  
210/41  
source  
E27 fluo/halo/led  
power  
1 x max 53W

# Spillo

---

design Studio Gibas





Famiglia di lampade a sospensione e parete in lastra di acciaio verniciata a polveri epossidiche. Ad ogni lampada, con l'apposita ghiera, può essere facilmente abbinato un disco diffusore in alluminio rendendola versatile per ogni ambiente.

Collection of suspension and wall lamps in epoxy powder coated steel plate. Each lamp, with the appropriate ring nut, can easily be combined with an aluminum diffuser disc making it versatile for any environment.

Kollektion von Hänge- und Wandleuchten aus pulverbeschichtetem Stahlblech. Jede Lampe kann dank der passenden Ringmutter leicht mit einer Diffusorscheibe aus Aluminium kombiniert werden, wodurch sie für jede Umgebung geeignet ist.

Série de suspensions et appliques murales en plaque en acier peint en poudre époxy. Chaque lampe peut s'adapter à tout environnement grâce à l'application d'un disque diffuseur en aluminium combiné avec son écrou approprié.

---

160/21+D2  
C2



---

160/14  
C2



---

160/41  
C2



160/44+G  
C2





160/41  
C2



160/21+D2+G  
C2





C 2  
black opaque

Accessory

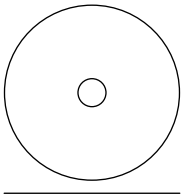

Ø 25

code  
160/D2  
disk



Ø 2

code  
160/S  
decentralizer



Ø 4

code  
160/G  
ring



Pendant  
code  
160/21  
source  
E27 fluo/halo/led  
power  
1 x max 53W  
cable length  
150 cm

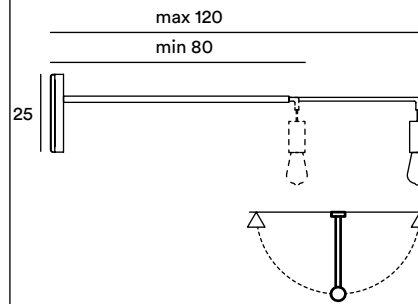

Wall  
code  
160/44  
source  
E27 fluo/halo/led  
power  
1 x max 53W  
cable length  
400 cm

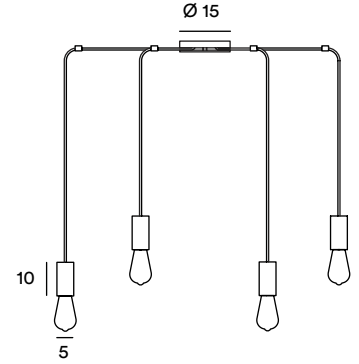

Pendant  
code  
160/14  
source  
E27 fluo/halo/led  
power  
4 x max 53W  
cable length  
150 cm

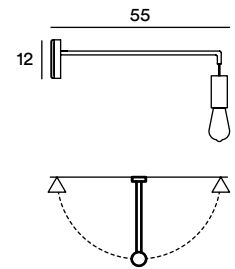

Wall  
code  
160/41  
source  
E27 fluo/halo/led  
power  
1 x max 53W  
cable length  
300 cm

# Priamo

---

design Giulio Giacomozzi





197/41  
C1



Famiglia di lampade a sospensione e parete, dalle forme piramidali di grandezze diverse, realizzata in lamiera di acciaio traforata e verniciata a polveri epossidiche. La struttura metallica filtra la luce creando un particolare effetto luminoso nell'ambiente.

Collection of pendant and wall lamps with pyramid shapes of different sizes, made of perforated sheet steel and epoxy paint. The metal structure filters the light by creating a particular lighting effect in the environment.

Kollektion von Pendel- und Wandleuchten in Pyramidenformen in verschiedenen Größen aus perforiertem, pulverbeschichtetem Stahlblech. Die Metallstruktur filtert das Licht und schafft so einen besonderen Lichteffect

Série de suspensions et appliques murales de forme pyramidale de différentes dimensions, réalisées en tôle en acier perforé et peint en poudre époxy. La structure métallique filtre la lumière en créant un flux lumineux particulier dans l'environnement.

---

197/42  
C84



197/26-27  
C2







197/26  
C84



---

197/41  
C2



197/22  
C13



197/42  
C84

 C 1  
white opaque

 C 2  
black opaque

 C 13  
copper

 C 84  
coated gold

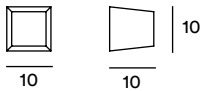

Wall  
code  
197/41  
source  
E14 fluo/halo/led  
power  
1 x max 40W

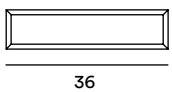

Wall  
code  
197/42  
source  
E14 fluo/halo/led  
power  
2 x max 40W

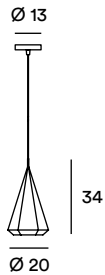

Pendant  
code  
197/22  
source  
E27 fluo/halo/led  
power  
1 x max 53W  
cable lenght  
150 cm

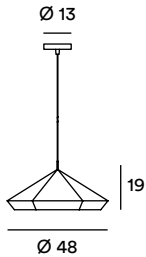

Pendant  
code  
197/25  
source  
E27 fluo/halo/led  
power  
1 x max 53W  
cable lenght  
150 cm

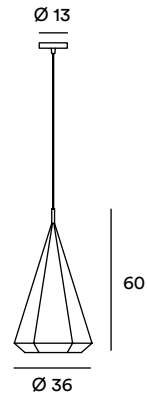

Pendant  
code  
197/23  
source  
E27 fluo/halo/led  
power  
1 x max 53W  
cable lenght  
150 cm

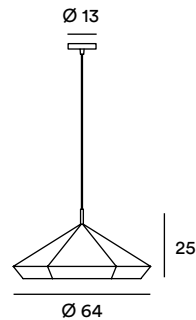

Pendant  
code  
197/26  
source  
E27 fluo/halo/led  
power  
1 x max 53W  
cable lenght  
150 cm

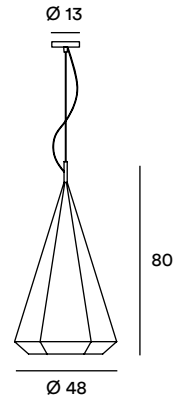

Pendant  
code  
197/24  
source  
E27 fluo/halo/led  
power  
1 x max 53W  
cable lenght  
110 cm

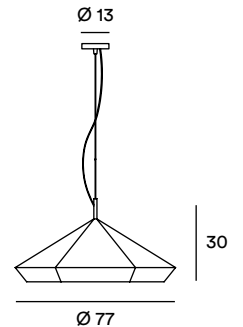

Pendant  
code  
197/27  
source  
E27 fluo/halo/led  
power  
1 x max 53W  
cable lenght  
110 cm

# Remì

---

design Paolo Giacomozzi

---

139/41  
C1+C60



---

139/61  
C2+C60



Famiglia di lampade da parete e da terra, in lastra di acciaio sagomata. Superficie esterna della struttura verniciata a polveri epossidiche, interno decorato a mano in foglia oro o foglia argento.

Collection of wall and floor lamps made of steel and shaped by hand. The outer surface of the structure is powder coated, interior decorated by hand in gold foil or silver foil.

Kollektion von Wand- und Bodenleuchten aus handgeformten Stahl. Die Aussenseite der Struktur ist pulverbeschichtet, die Innenseite von Hand mit Blattgold oder Blattsilber verziert.

Série d'appliques murales et lampes sur pied en plaque en acier profilé. Extérieur de la structure peint en poudre époxy, intérieur décoré à la main en feuille d'or ou feuille d'argent.

---

139/61  
C1+C60



139/41  
C2+C60



139/41  
C1+C60

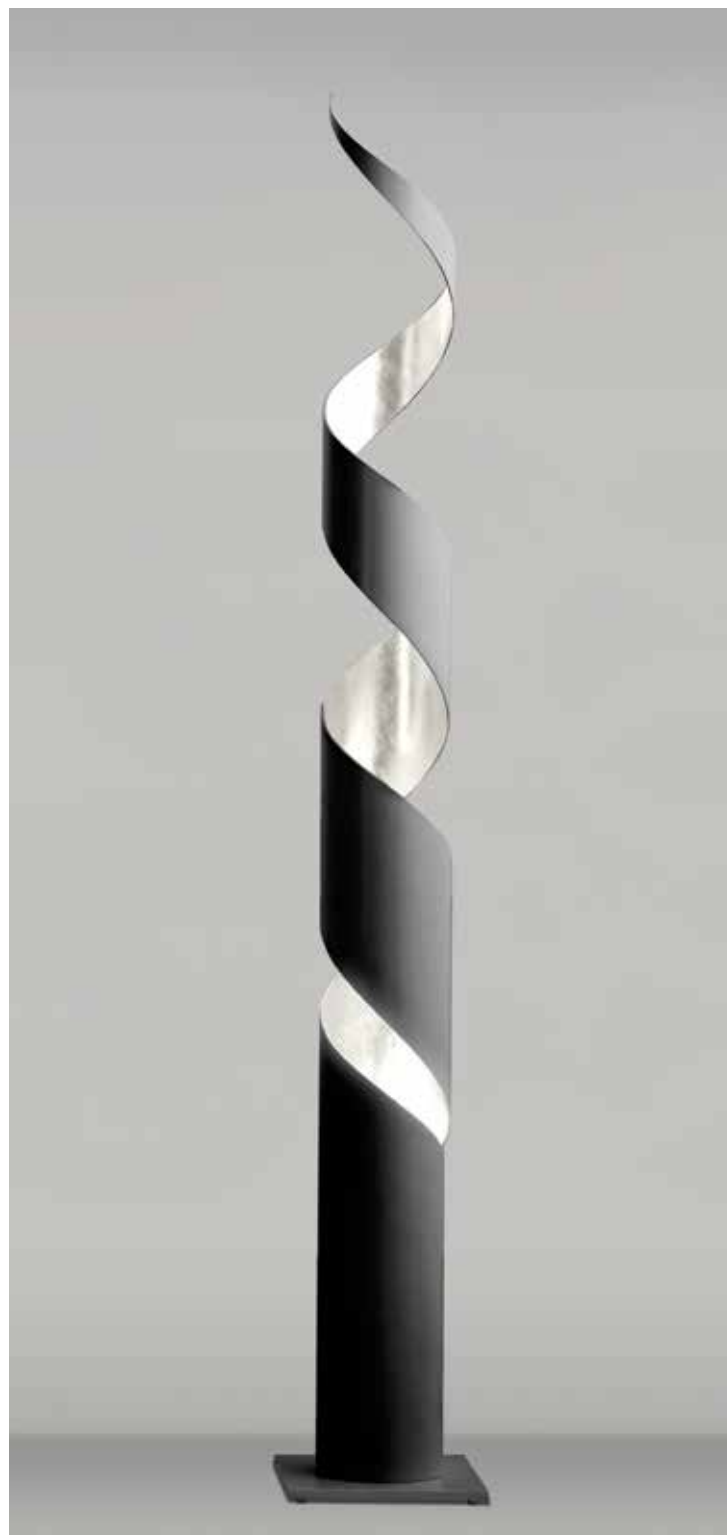

139/61  
C2+C75

 C 1  
white opaque

 C 2  
black opaque

 C 60  
goldfoil (inside)

 C 75  
silverfoil (inside)

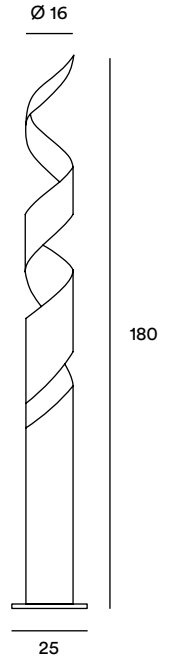
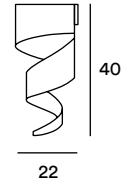

Wall  
code  
139/41  
source  
E27 fluo/halo/led  
power  
1 x max 53W

Floor  
code  
139/61  
source  
E27 fluo/halo/led  
power  
1 x max 53W

# Titti

---

design Giulio Giacomozzi

---

170/23  
C7

---

170/21  
C7



---

170/22  
C7



Famiglia di lampade da tavolo, soffitto e sospensione dalla struttura in tondino d'acciaio verniciato a polveri epossidiche. Possibilità di montare l'accessorio paralume di tessuto bianco testurizzato.

Collection of table, ceiling and suspension lamps made of powder coated tubular steel. Ability to mount accessory lamp shade of white fabric.

Kollektion von Tisch-, Decken- und Hängeleuchten mit fadenförmiger Struktur aus pulverbeschichtetem Metall. Der Lampenschirm aus weißen Stoff kann als Zubehör montiert werden.

Série de lampes de table, plafonniers et suspensions avec structure en tige d'acier peint en poudre époxy. Possibilité d'installer l'accessoire abat-jour en tissu texturé blanc.

---

170/22  
C7





170/34  
C2



170/34  
C7







---

170/21  
C2

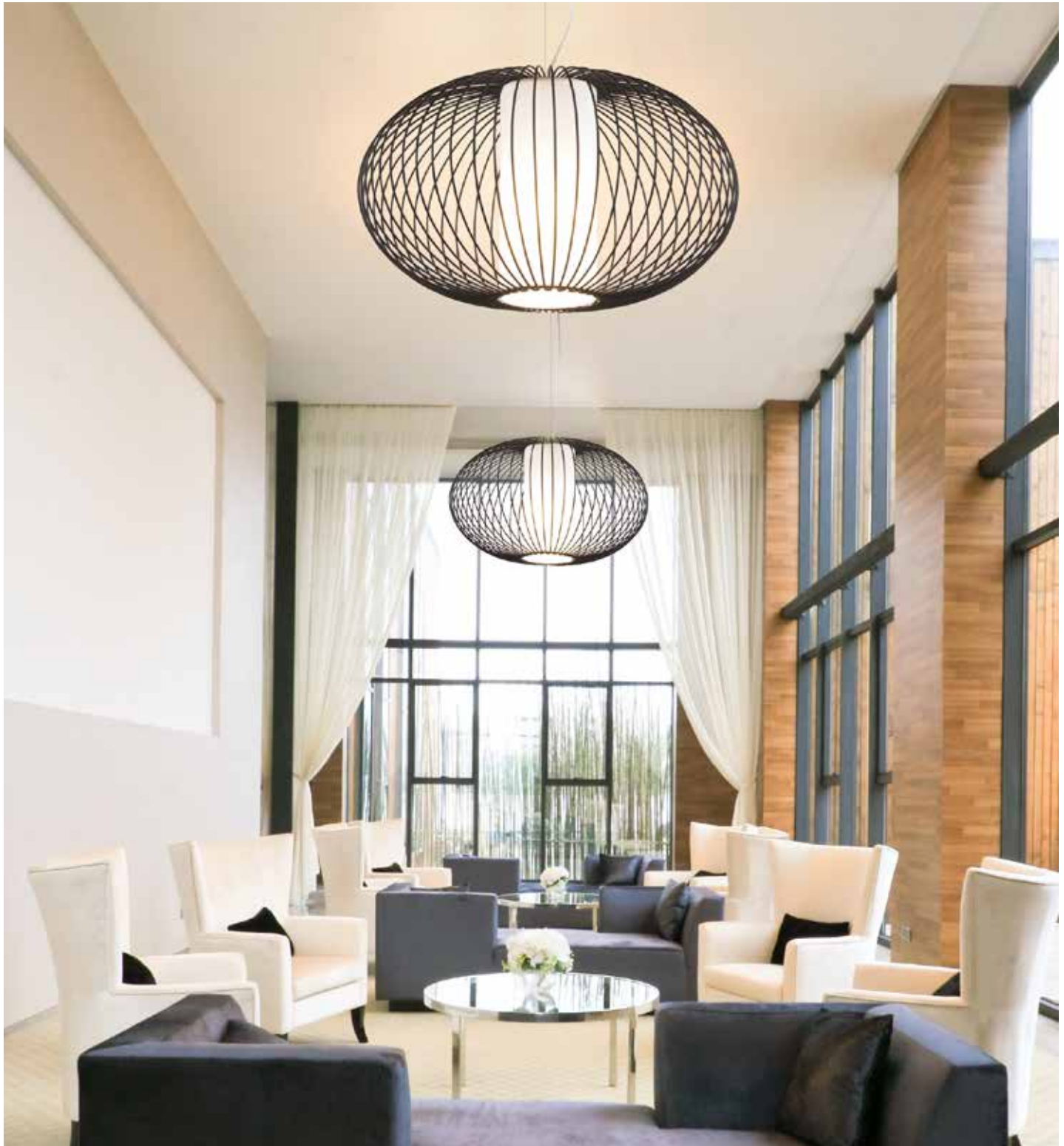

170/29  
C2



---

170/74  
C2



---

170/34 + P4  
C2

---

170/23 + P3  
C7



 C 2  
black opaque

 C 7  
ivory

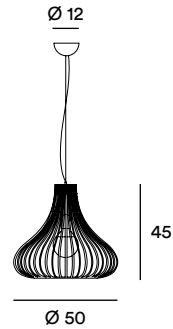

Pendant  
code  
170/21  
source  
E27 fluo/halo/led  
power  
1 x max 53W  
cable length  
110 cm

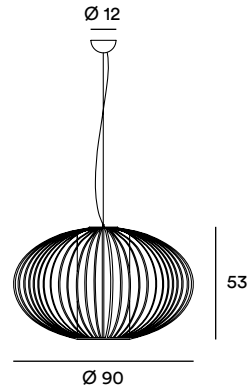

Pendant  
code  
170/29  
source  
E27 fluo/halo/led  
power  
1 x max 53W  
cable length  
110 cm  
note  
lampshade included

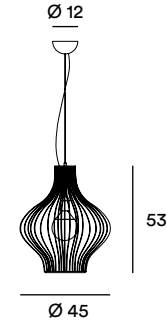

Pendant  
code  
170/22  
source  
E27 fluo/halo/led  
power  
1 x max 53W  
cable length  
110 cm

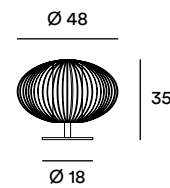
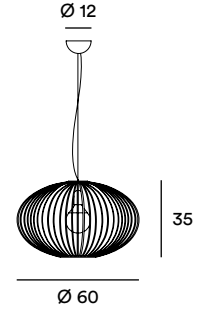
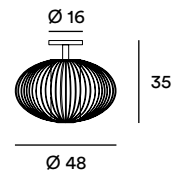

Table  
code  
170/34  
source  
E27 fluo/halo/led  
power  
1 x max 53W



Pendant  
code  
170/23  
source  
E27 fluo/halo/led  
power  
1 x max 53W  
cable length  
110 cm



Ceiling  
code  
170/74  
source  
E27 fluo/halo/led  
power  
1 x max 53W

# Chaplin

---

design Giulio Giacomozzi

---

195/26  
C57



---

195/24  
C57



---

195/25  
C57





195/26-64  
C57

Famiglia di lampade da terra e sospensione realizzata in tondino d'acciaio sagomato e verniciato a polveri epossidiche. Le due fasce che chiudono il corpo tondeggiante sono in legno naturale.

Collection of floor and pendant lamps made of shaped and powder coated steel rod. The two bands that close the round body are made of natural wood.

Kollektion von Steh- und Hängeleuchten aus geformten und pulverbeschichteten Metallstäben. Die beiden Ringe die den runden Lampenkörper umschließen sind aus Naturholz.

Série de lampes sur pied et suspensions réalisées en tige en acier profilé et peint en poudre époxy. Corps arrondi de la lampe renfermé entre deux bandes en bois naturel.

195/65  
C57







195/24+P  
C57



195/24  
C57





---

195/65  
C57



---

195/64  
C57

---

195/26  
C57





C 57  
coffee



wood

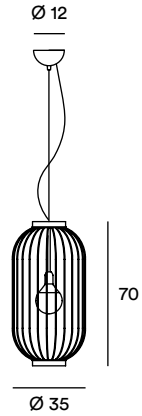

Pendant  
code  
195/24  
source  
E27 fluo/halo/led  
power  
1 x max 53W  
cable length  
110 cm

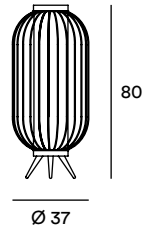

Floor  
code  
195/64  
source  
E27 fluo/halo/led  
power  
1 x max 53W  
note  
lampshade included

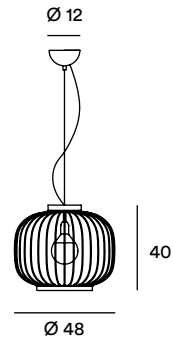

Pendant  
code  
195/25  
source  
E27 fluo/halo/led  
power  
1 x max 53W  
cable length  
110 cm

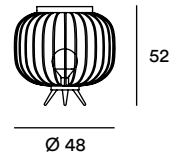
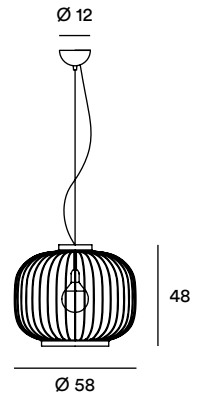

Table  
code  
195/65  
source  
E27 fluo/halo/led  
power  
1 x max 53W



Pendant  
code  
195/26  
source  
E27 fluo/halo/led  
power  
1 x max 53W  
cable length  
110 cm

# Lori

---

design Giulio Giacomozzi

---

185/23  
C2



---

185/22  
C13



---

185/22  
C13

Famiglia di lampade a sospensione in tondino d'acciaio saldato e verniciato a polveri epossidiche. Disponibile in tre diverse forme.

Pendant lamp with a tubular steel welded and powder coated. Available in three different forms.

Hängeleuchte in Stahlstange geschweißt und mit Epoxidpulver lackiert. Erhältlich in drei verschiedenen Formen.

Série de suspensions en tige en acier soudé et peint en poudre époxy. Disponible en trois formes différentes.

---

185/21  
C1







---

185/21-22-23  
C2





185/22  
C13



 C 1  
white opaque

 C 2  
black opaque

 C 13  
copper

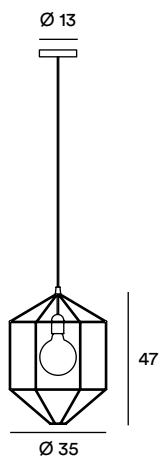

Pendant  
code  
185/21  
source  
E27 fluo/halo/led  
power  
1 x max 53W  
cable length  
150 cm

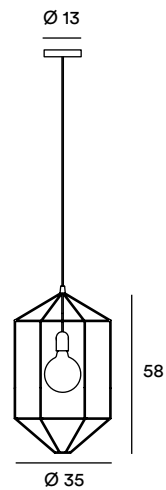

Pendant  
code  
185/22  
source  
E27 fluo/halo/led  
power  
1 x max 53W  
cable length  
150 cm

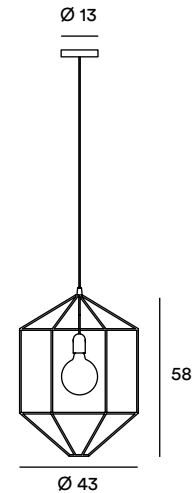

Pendant  
code  
185/23  
source  
E27 fluo/halo/led  
power  
1 x max 53W  
cable length  
150 cm



# Luxor

---

design Giulio Giacomozzi

---

190/74  
C1



---

190/76  
C1



---

190/76  
C1

Famiglia di lampade da parete e soffitto composta da tre componenti in lastra di acciaio, verniciato a polveri epossidiche, di forma rotonda o quadrata, che possono essere disposti agevolmente, anche dopo l'installazione, in molteplici posizioni.

Collection of wall and ceiling lamps composed of three components in steel plate, coated with epoxy powders, of round or square shape, which can be easily arranged, even after installation in multiple positions.

Kollektion von Wand- und Deckenleuchten aus drei Komponenten in Stahlblech, mit Epoxidpulver beschichtet, in runder oder quadratischer Form die auch nach der Installation leicht in mehreren Positionen angeordnet werden können.

Série de plafonniers et appliques murales composées de trois pièces en plaque en acier peint en poudre époxy, de forme ronde ou carrée, qui présentent plusieurs possibilités de positionnement, même après l'installation.







---

190/74  
C1



190/76  
C57





190/75  
C1



190/73  
C57



 C 1  
white opaque

 C 57  
coffee

some possible combinations

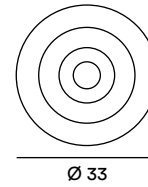
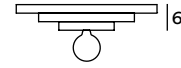
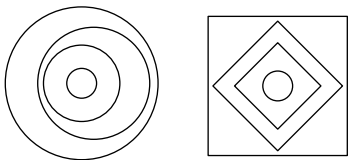
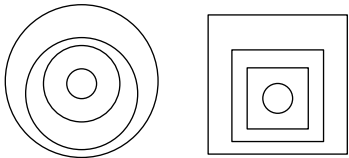
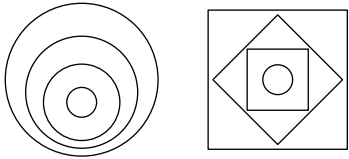

Wall-Ceiling  
code  
190/73  
source  
E27 fluo/halo/led  
power  
1 x max 53W

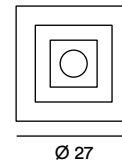
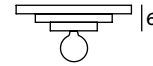

Wall-Ceiling  
code  
190/75  
source  
E27 fluo/halo/led  
power  
1 x max 53W

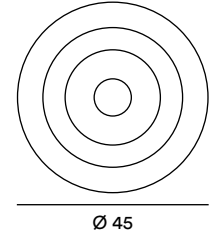
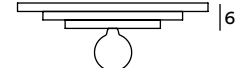

Wall-Ceiling  
code  
190/74  
source  
E27 fluo/halo/led  
power  
1 x max 53W

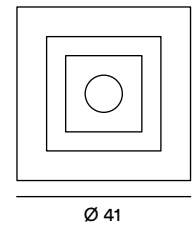
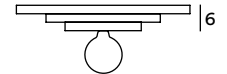

Wall-Ceiling  
code  
190/76  
source  
E27 fluo/halo/led  
power  
1 x max 53W



# Kuadra

---

design Studio Gibas



---

173/76  
C89



---

173/74  
C89



---

173/76  
C89

Lampada da soffitto e parete realizzata  
in lastre di acciaio verniciate a polveri  
epossidiche ed assemblate in diversi  
colori.

Collection of Ceiling and wall lamps  
made of steel sheets coated with epoxy  
powders and assembled in different  
colors.

Kollektion von Decken- und  
Wandleuchten aus mit Epoxidpulver  
beschichteten und in verschiedenen  
Farben zusammengesetzten Stahlblechen.

Plafonnier et applique murale en plaques  
en acier peint en poudres époxy et  
assemblés en couleurs différentes.





173/74  
C89

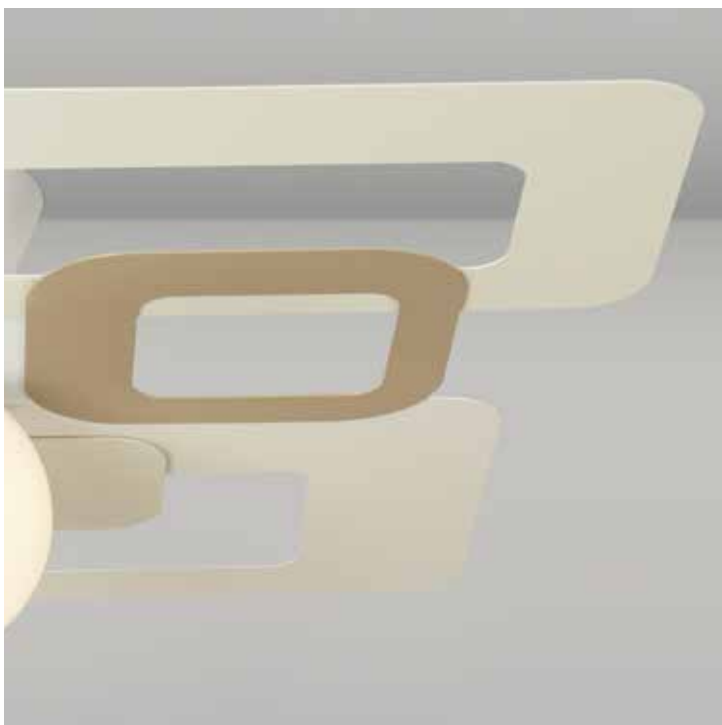

173/74  
C89

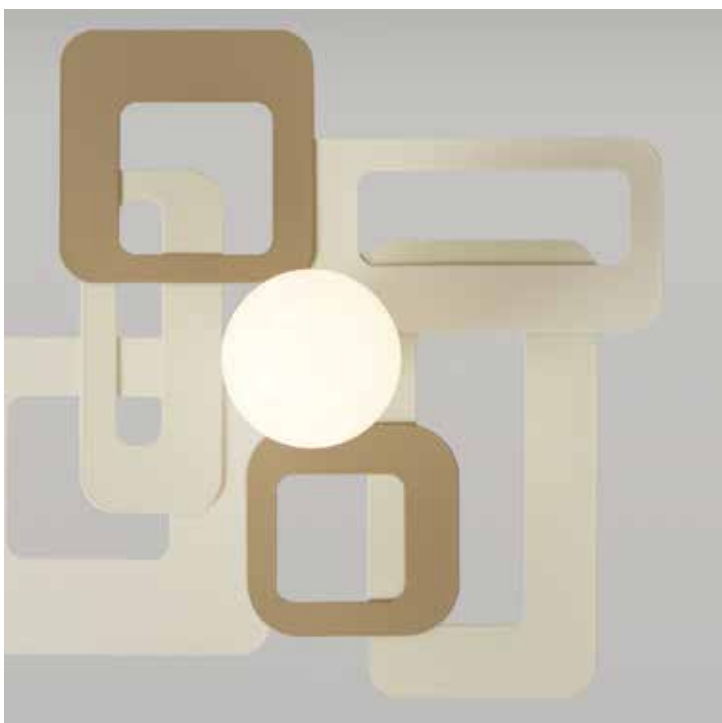

173/76  
C89



 C 89  
milk & honey

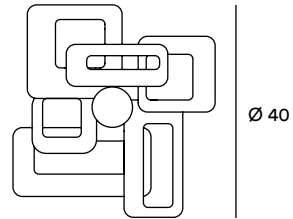
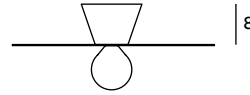

Wall-Ceiling  
code  
173/74  
source  
E27 fluo/halo/led  
power  
1 x max 53W

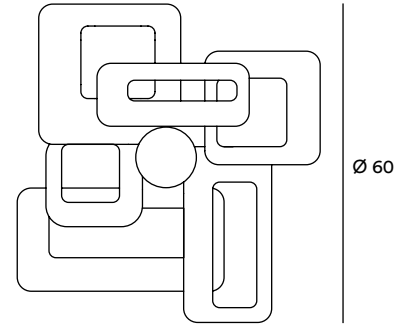
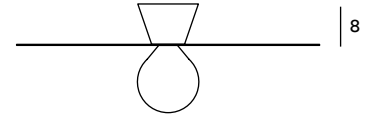

Wall-Ceiling  
code  
173/76  
source  
E27 fluo/halo/led  
power  
1 x max 53W



# Rail

---

design Studio Gibas



---

171/76  
C91



---

171/74  
C91



---

171/76  
C91

Lampada da soffitto e parete realizzata  
in lastre di acciaio verniciate a polveri  
epossidiche ed assemblate in diversi  
colori.

Collection of Ceiling and wall lamps  
made of steel sheets coated with epoxy  
powders and assembled in different  
colors.

Kollektion von Decken- und  
Wandleuchten aus mit Epoxidpulver  
beschichteten und in verschiedenen  
Farben zusammengesetzten Stahlblechen.

Plafonnier et applique murale en plaques  
en acier peint en poudres époxy et  
assemblés en couleurs différentes.



---

171/74  
C91



171/76  
C91

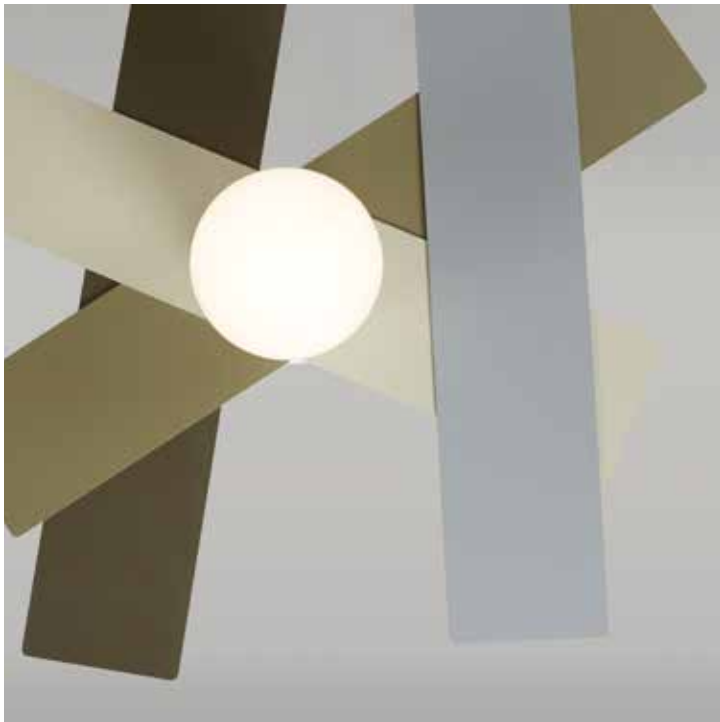

171/76  
C91

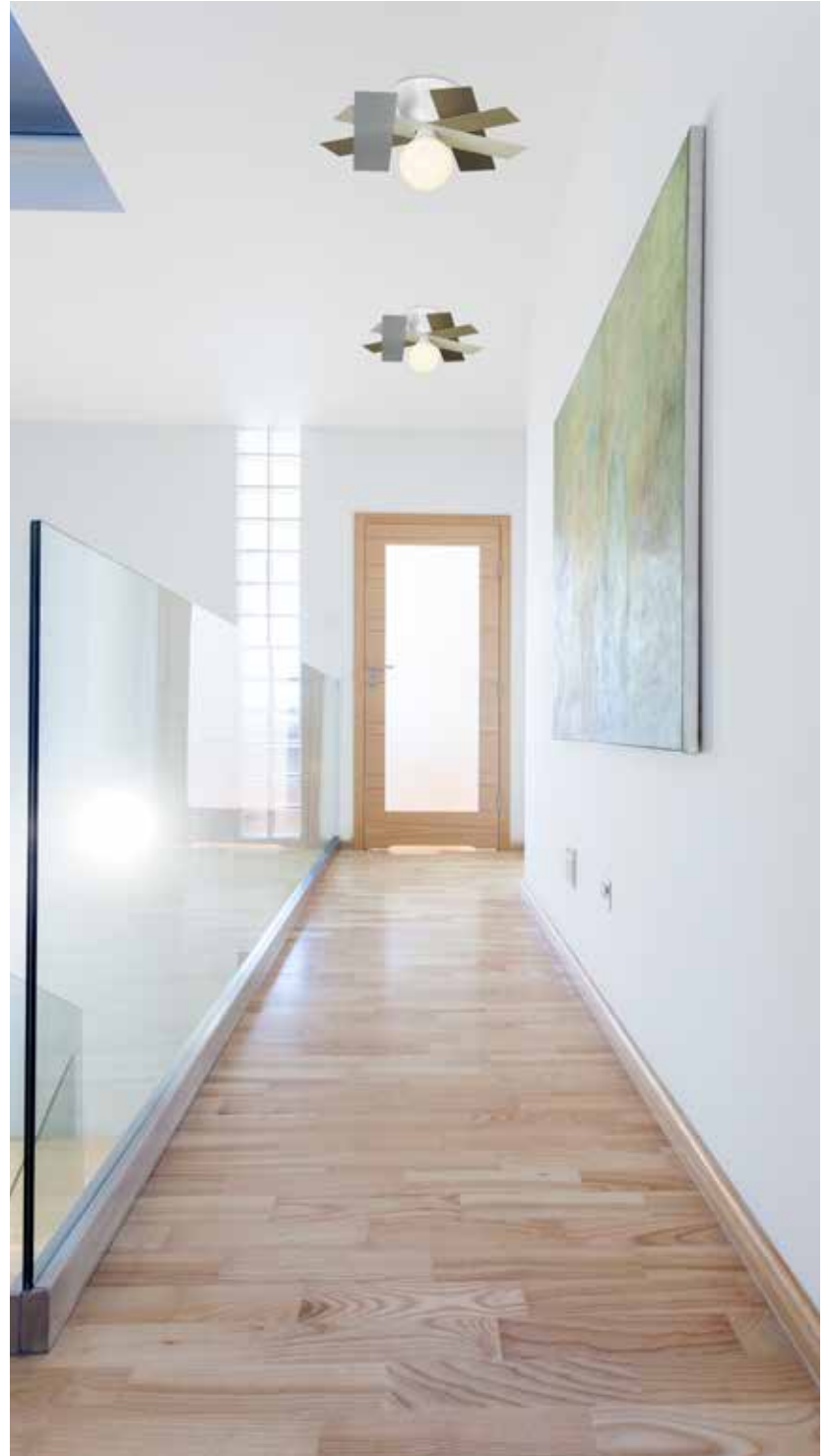



C 91  
storm

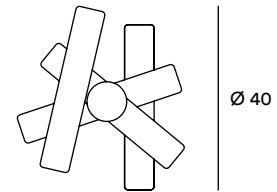
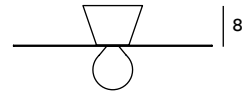

Wall-Ceiling  
code  
171/74  
source  
E27 fluo/halo/led  
power  
1 x max 53W

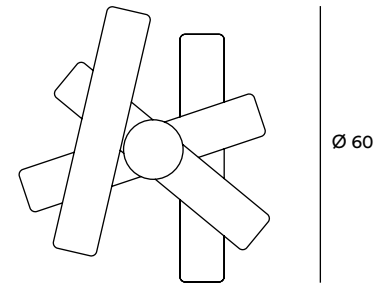
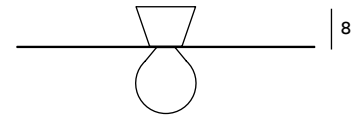

Wall-Ceiling  
code  
171/76  
source  
E27 fluo/halo/led  
power  
1 x max 53W





# Dolce

---

design Studio Gibas





---

192/45  
C36

Famiglia di lampade da parete disponibile in diverse dimensioni, realizzata in lastra di acciaio curvata e verniciata a polveri epossidiche. Il modulo LED integrato a tensione di rete permette un'omogenea illuminazione indiretta attraverso il diffusore in metacrilato opalino.

Wall lamp available in different sizes, made of an epoxy coated steel frame. The integrated high voltage LED module allows a homogeneous indirect lighting through the opal methacrylate diffuser.

Wandleuchte, aus geformtem pulverbeschichtetem Stahlblech, in verschiedenen Größen erhältlich. Das integrierte Hochvolt LED Modul ermöglicht eine homogene indirekte Beleuchtung durch den matten methacrylat Diffusor.

Série d'appliques murales disponibles en différentes dimensions, réalisées en plaque en acier courbe et peint en poudre époxy. Le module LED intégré à tension de secteur assure un éclairage indirect homogène à travers le diffuseur en méthacrylate opalescent.

192/43  
C35





---

192/41  
C80



---

192/43  
C35

---

192/41  
C36



 C 35  
concrete

 C 36  
corten

 C 80  
sand white

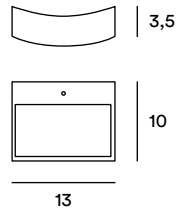

Wall  
code  
192/41  
source  
led board  
power  
1 × 8W  
luminous flux  
600 lm  
CCT  
2700K

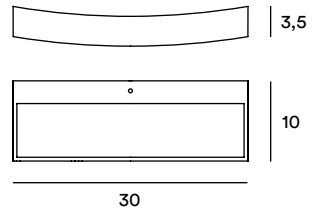

Wall  
code  
192/43  
source  
led board  
power  
1 × 13W  
luminous flux  
1450 lm  
CCT  
2700K

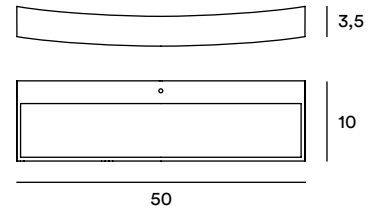

Wall  
code  
192/45  
source  
led board  
power  
2 × 13W  
luminous flux  
2900 lm  
CCT  
2700K

# Gradino

---

design Studio Gibas







Famiglia di lampade da parete in lastra sagomata e verniciata a polveri epossidiche, disponibile in due dimensioni. Presente anche la versione a LED integrato con diffusore in metacrilato opalino.

Collection of Wall lamps in shaped metal sheet epoxy painted available in two sizes. Also available with integrated LED with opal methacrylate diffuser.

Kollektion von Wandlampen in geformtem, pulverbeschichtetem Blech, verfügbar in zwei Größen. Auch mit integrierter LED mit opalem Methacrylat-Diffusor erhältlich.

Série d'appliques murales en plaque profilée et peinte en poudre époxy. Disponibles en deux dimensions et dans la version avec LED intégrée et diffuseur méthacrylate opalescent.

---

176/42  
C69





---

176/45  
C69



---

176/45  
C69

---

176/46  
C57





C 1  
white opaque



C 57  
coffee



C 69  
aluminum



9



9

9

Wall  
code  
176/41  
source  
G9 fluo/halo/led  
power  
1 x max 40W



9



9

9

Wall  
code  
176/45  
source  
led board  
power  
8W  
luminous flux  
lm  
CCT  
2700K



33

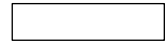

8

33

Wall  
code  
176/42  
source  
E27 fluo/halo/led  
power  
1 x max 53W

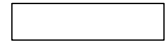

33

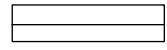

8

33

Wall  
code  
176/46  
source  
led board  
power  
18W  
luminous flux  
1980 lm  
CCT  
2700K

# Valencia

---

design Giulio Giacomozzi

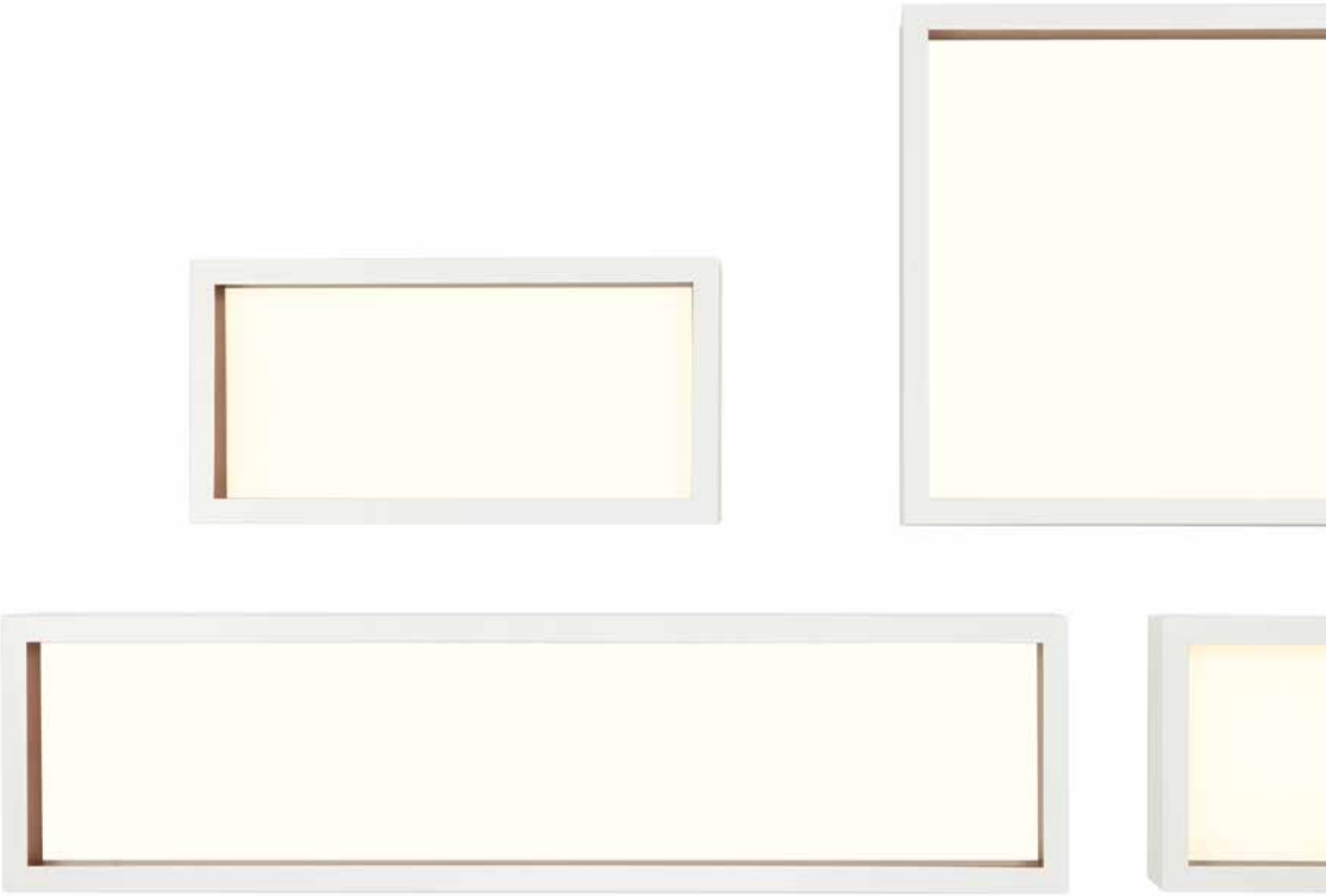



Famiglia di lampade da parete e soffitto di forma quadrata e rettangolare disponibile in quattro dimensioni, con struttura in lastra di acciaio verniciato bicolore a polveri epossidiche per una gradevole ed omogenea illuminazione.

Collection of square and rectangular wall and ceiling lamps available in four sizes, with structure in two-colored epoxy powder coated steel plate for a pleasant and homogeneous lighting.

Kollektion von quadratischen und rechteckigen Wand- und Deckenleuchten in vier Größen, mit Struktur aus zweifarbigem pulverbeschichtetem Stahlblech für eine angenehme und homogene Beleuchtung.

Série de plafonniers et appliques murales carrés et rectangulaires disponibles en quatre dimensions. Structure en plaque en acier peint en deux couleurs en poudre époxy créant un éclairage agréable et homogène.







205/77  
C1+C13



205/78  
C1+C84



205/72  
C1+C84





205/72  
C57+C84



 C 1  
white opaque

 C 57  
coffee

 C 13  
copper (inside)

 C 84  
coated gold (inside)

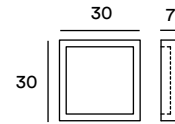

Wall-Ceiling  
code  
205/72  
source  
led board  
power  
18W LED  
luminous flux  
1420 Lm  
CCT  
3000K  
dimnable

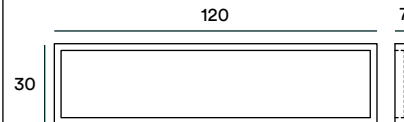

Wall-Ceiling  
code  
205/77  
source  
led board  
power  
36W LED  
luminous flux  
3850 Lm  
CCT  
3000K  
dimnable

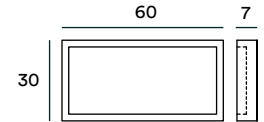

Wall-Ceiling  
code  
205/75  
source  
led board  
power  
36W LED  
luminous flux  
3450 Lm  
CCT  
3000K  
dimnable

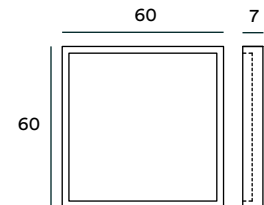

Wall-Ceiling  
code  
205/78  
source  
led board  
power  
36W LED  
luminous flux  
3400 Lm  
CCT  
3000K  
dimnable

The background of the entire image consists of a series of concentric circles centered in the middle. The circles are thin and light gray, creating a subtle, hypnotic pattern that fills the entire frame. The spacing between the circles is uniform, and they radiate outwards from the center.

# Moon

---

design Studio Gibas





---

144/74  
C35

Famiglia di lampade da parete, soffitto e sospensione con emissione luminosa a LED, in lastra di acciaio con decoro laser, verniciata a polveri epossidiche.

Collection of wall, ceiling and suspension lamps with LED light emission, in steel plate with laser decoration, coated with epoxy powders.

Kollektion von Wand-, Decken- und Hängeleuchten mit integrierter LED, Metallgestell mit Laser-Dekor, mit Epoxidpulver beschichtet.

Série d'appliques murales, plafonniers et suspensions avec source lumineuse LED en plaque en acier peint en poudre époxy avec décoration laser.



144/26  
C36





---

144/76  
C36





---

144/76  
C36



---

144/74  
C35

---

144/76  
C36



 C 35  
concrete

 C 36  
corten

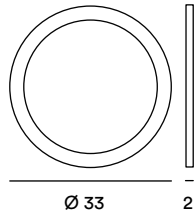

Wall-Ceiling

code  
144/73  
source  
led board  
power  
28W  
luminous flux  
2100 Lm  
CCT  
2700K

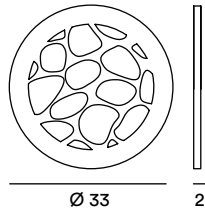

Wall-Ceiling

code  
144/75  
source  
led board  
power  
28W  
luminous flux  
2100 Lm  
CCT  
2700K

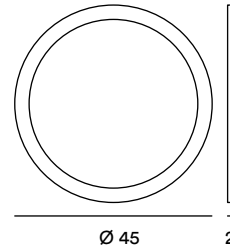

Wall-Ceiling

code  
144/74  
source  
led board  
power  
38W  
luminous flux  
3000 Lm  
CCT  
2700K

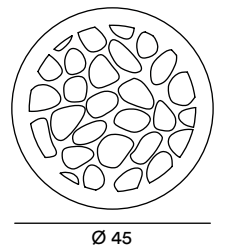

Wall-Ceiling

code  
144/76  
source  
led board  
power  
38W  
luminous flux  
3000 Lm  
CCT  
2700K

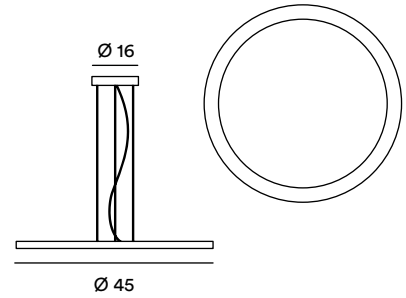

Pendant

code  
144/24  
source  
led board  
power  
38W  
luminous flux  
3000 Lm  
CCT  
2700K  
cable length  
110 cm

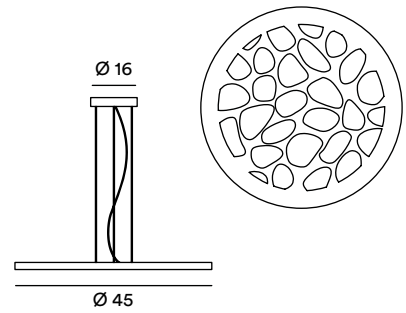

Pendant

code  
144/26  
source  
led board  
power  
38W  
luminous flux  
3000 Lm  
CCT  
2700K  
cable length  
110 cm

# Victoria

---

design Studio Gibas

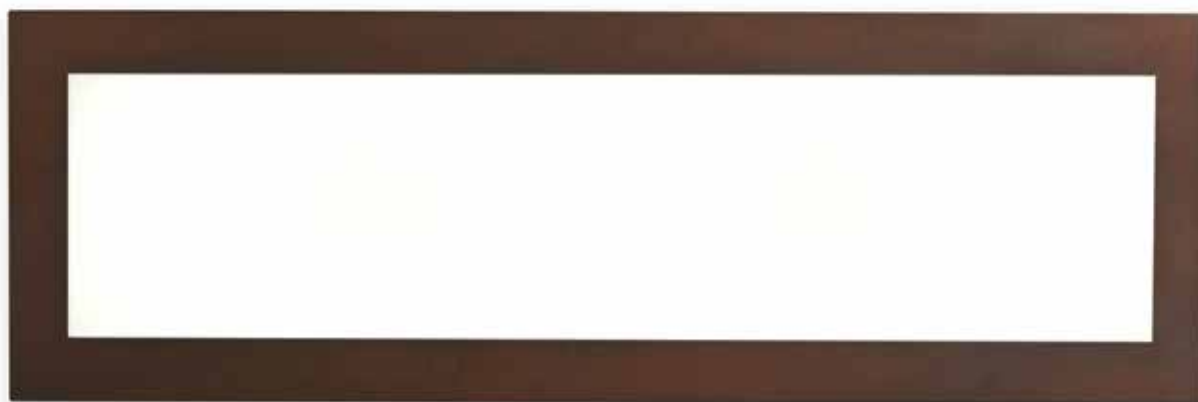



148/78  
C35

Famiglia di lampade da parete, soffitto e sospensione di forma quadrata e rettangolare in quattro dimensioni, con struttura in acciaio tagliato a laser e verniciato a polveri epossidiche, emissione di luce diretta e omogenea.

Collection of wall, ceiling and suspension lamps in four dimensions in square or rectangular shape. Laser-cut steel frame, epoxy coated with Opal acrylic diffuser for direct and homogeneous light emission.

Sammlung von Wand-, Decken- und Hängeleuchten in vier Abmessungen in quadratischer oder rechteckiger Form. Lasergeschnittener Stahlrahmen, epoxidbeschichtet mit Opal-Acryl-Diffusor für direkte und homogene Lichtemission.

Série d'appliques murales, plafonniers et suspensions de forme carrée et rectangulaire en quatre dimensions. Structure en acier découpée laser et peint en poudre époxy. Flux lumineux direct et homogène.







---

148/77  
C36





---

148/72  
C36



---

148/75  
C35

---

148/75  
C36



 C 35  
concrete

 C 36  
corten

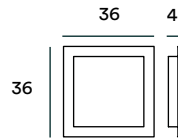

Wall-Ceiling  
code  
148/72  
source  
led board  
power  
18W IP40  
luminous flux  
1420 Lm  
CCT  
3000K  
dimnable

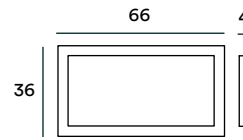

Wall-Ceiling  
code  
148/75  
source  
led board  
power  
36W IP40  
luminous flux  
3450 Lm  
CCT  
3000K  
dimnable

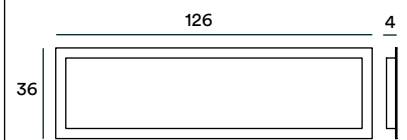

Wall-Ceiling  
code  
148/77  
source  
led board  
power  
36W IP40  
luminous flux  
3850 Lm  
CCT  
3000K  
dimnable

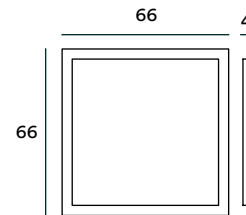

Wall-Ceiling  
code  
148/78  
source  
led board  
power  
36W IP40  
luminous flux  
3400 Lm  
CCT  
3000K  
dimnable

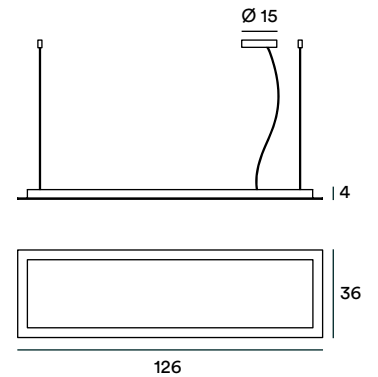

Pendant  
code  
148/27  
source  
led board  
power  
36W IP40  
luminous flux  
3850 Lm  
CCT  
3000K  
cable lenght  
110 cm  
dimnable

# Rocco

---

design Studio Gibas

---

923/5  
C2



---

923/10  
C1



923/5+P-923/41+P  
C2

Famiglia di lampade a sospensione, tavolo e applique, disponibile in diverse dimensioni, con bracci in acciaio sagomati a mano e verniciati a polveri epossidiche. Il paralume in tessuto è disponibile come accessorio.

Collection of Pendant, table and wall lights in different sizes and brackets in hand-shaped, epoxy powder coated steel. The fabric lampshade is available as an accessory.

Kollektion von Hänge-, Tisch- und Wandleuchten in verschiedenen Größen mit von Hand geformten, pulverbeschichteten Armen. Der Stoff Lampenschirm ist als Zubehör erhältlich.

Série de suspensions, lampes de table et appliques murales disponibles en différentes dimensions avec bras en acier profilé à la main et peint en poudre époxy. Abat-jour en tissu disponible comme accessoire.



923/10+P-923/41+P  
C1





923/31+P  
C1



923/41+P  
C1





C 1  
white opaque



C 2  
black opaque

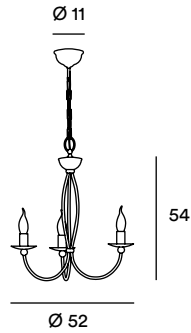

Pendant  
code  
923/3  
source  
E14 fluo/halo/led  
power  
3 x max 40W  
cable lenght  
60 cm  
accessory  
lampshade code 923/P

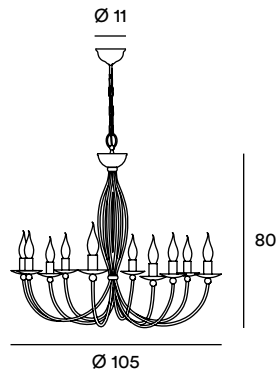

Pendant  
code  
923/10  
source  
E14 fluo/halo/led  
power  
10 x max 40W  
cable lenght  
60 cm  
accessory  
lampshade code 923/P

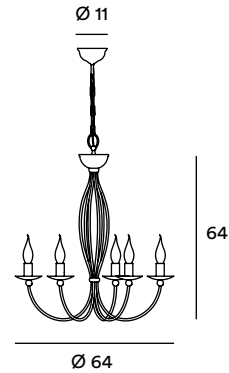

Pendant  
code  
923/5  
source  
E14 fluo/halo/led  
power  
5 x max 40W  
cable lenght  
60 cm  
accessory  
lampshade code 923/P

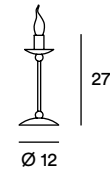
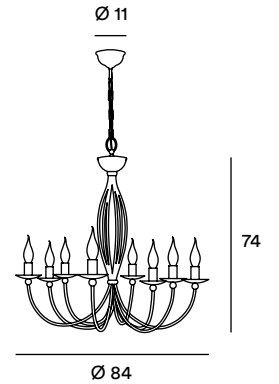
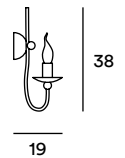

Table  
code  
923/31  
source  
E14 fluo/halo/led  
power  
1 x max 40W  
accessory  
lampshade code 923/P



Pendant  
code  
923/8  
source  
E14 fluo/halo/led  
power  
8 x max 40W  
cable lenght  
60 cm  
accessory  
lampshade code 923/P



Wall  
code  
923/41  
source  
E14 fluo/halo/led  
power  
1 x max 40W  
accessory  
lampshade code 923/P

# Gioconda

---

design Studio Gibas

---

189/24  
C35



---

189/25  
C36



189/25  
C36

Famiglia di lampade a sospensione e parete realizzate con fasce di acciaio saldate e verniciate a polveri epossidiche. La sorgente LED a tensione di rete è collocata sul dissipatore in fusione d'alluminio. Il doppio diffusore in metacrilato satinato permette l'emissione luminosa diretta e indiretta.

Collection of pendant and floor lamps made of shaped and welded steel bands. The integrated high voltage LED light source resides in sink cast aluminum. Light emission direct and indirect through the frosted methacrylate diffuser.

Kollektion von Hänge- und Stehleuchten aus geformten und geschweißten Metallbändern. Die integrierte Hochvolt LED Lichtquelle liegt in einer Wanne aus Aluminiumguss. Die Lichtemission ist direkt und indirekt durch den Diffusor aus satiniertem Metacrylat.

Série de suspensions et d'appliques murales réalisées avec bandes en acier soudées et peintes en poudre époxy. La source lumineuse LED à tension de secteur se trouve dans le dissipateur en fonte d'aluminium. Eclairage direct et indirect à travers un double diffuseur en méthacrylate satiné.





189/24  
C35





C 35  
concrete



C 36  
corten

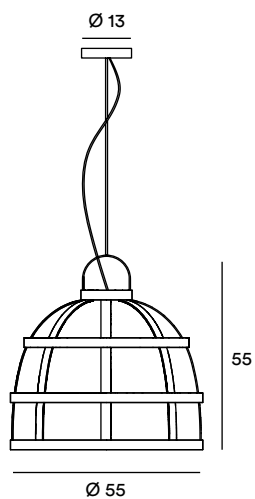

Pendant  
code  
189/25  
source  
led board  
power  
1 × 17W  
luminous flux  
1500lm  
CCT  
2700K  
cable lenght  
110 cm

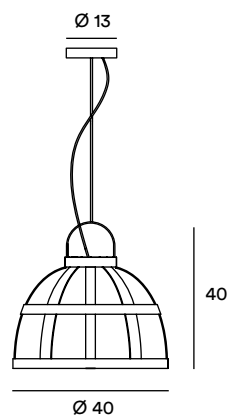

Pendant  
code  
189/24  
source  
led board  
power  
1 × 17W  
luminous flux  
1500lm  
CCT  
2700K  
cable lenght  
110 cm

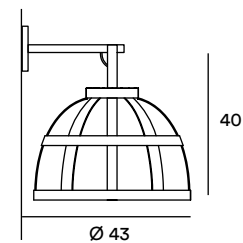

Wall  
code  
189/44  
source  
led board  
power  
1 × 17W  
luminous flux  
1500lm  
CCT  
2700K



# Baja

---

design Studio Gibas

---

902/23  
C51



---

902/24  
C57

---

902/24  
C7



902/24  
C51

Famiglia di lampade da soffitto, sospensione e parete realizzata in acciaio verniciato a polveri epossidiche. Diffusori con schermo bianco interno per una maggiore riflessione della luce. Nella versione a sospensione il cavo elettrico è in tessuto intrecciato.

Collection of ceiling, suspension and wall lamps made of powder coated steel.

Diffusers with white screen inside for greater reflection of light. In the pendant version, the electrical cable is made of woven fabric.

Kollektion von Decken-, Wand- und Hängeleuchten aus pulverbeschichtetem Metall. Der Lampenschirm ist im Inneren weiß für größere Lichtausbeute. Bei der Hängevariante ist das Kabel gewebtem Stoff.

Série de plafonniers, suspensions et appliques murales réalisés en acier peint en poudre époxy. Diffuseurs avec écran blanc à l'intérieur pour une plus ample réflexion de la lumière. Cordon d'alimentation en tissu tressé dans la version à suspension.



902/73  
C7



902/24  
C7



902/73  
C7





C 7  
ivory



C 51  
sage green



C 57  
coffee

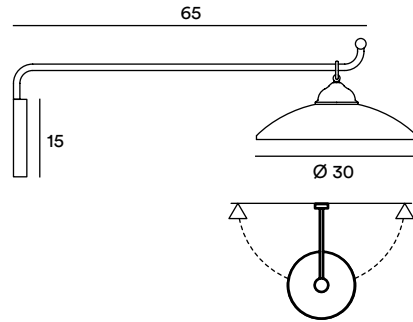

Wall  
code  
902/43  
source  
E27 fluo/halo/led  
power  
1 x max 53W

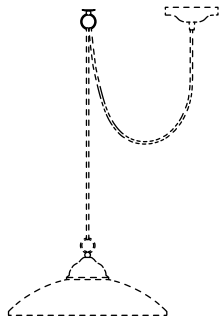

Accessory  
code  
902/d  
support for decentralization

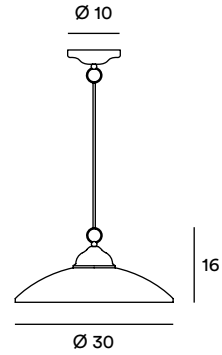

Pendant  
code  
902/23  
source  
E27 fluo/halo/led  
power  
1 x max 53W  
cable length  
150 cm

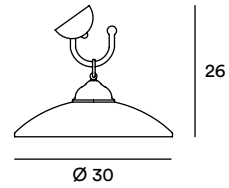

Ceiling  
code  
902/73  
source  
E27 fluo/halo/led  
power  
1 x max 53W

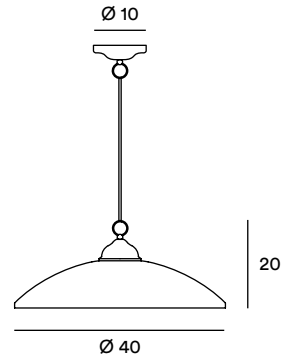

Pendant  
code  
902/24  
source  
E27 fluo/halo/led  
power  
1 x max 53W  
cable length  
150 cm

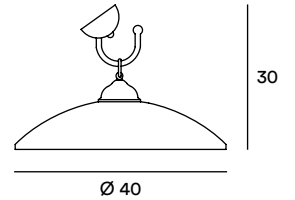

Ceiling  
code  
902/74  
source  
E27 fluo/halo/led  
power  
1 x max 53W

# Rua

---

design Studio Gibas

---

837/24  
C7+C51



---

837/24  
C57+C43







837/24  
C57+C43



Famiglia di lampade a sospensione e soffitto disponibile in diverse misure realizzata in acciaio verniciato a polveri epossidiche, con diffusore in acciaio o in ottone ossidato. Il cavo elettrico della versione a sospensione è in tessuto intrecciato.

Pendant and ceiling lamps available in different sizes made of powder coated steel with diffuser in oxidized brass or steel. The power cord of the hanging version is woven fabric.

Hänge- und Deckleuchten in verschiedenen Größen mit pulverbeschichtetem Metallgestell. Der Lampenschirm ist aus oxidiertem Messing oder Metall. Das Netzkabel des Hängevariante ist aus gewebtem Stoff.

Série de suspensions et plafonniers disponibles en différentes dimensions, réalisés en acier peint en poudre époxy avec diffuseur en acier ou laiton oxydé. Cordon d'alimentation en tissu tressé dans la version à suspension.

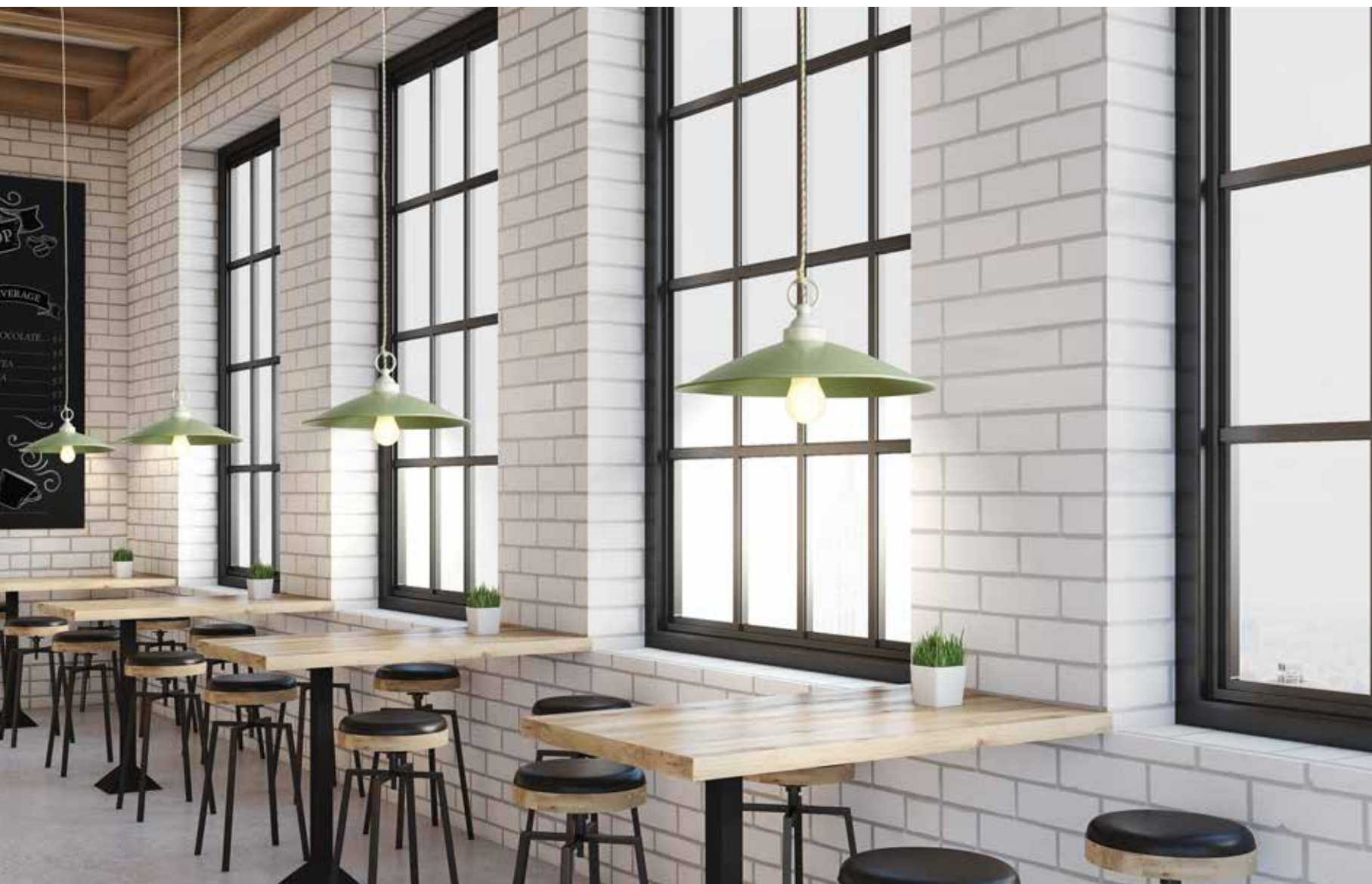





837/72  
C57+C43





837/24  
C57+C43



 C 7  
ivory (structure)

 C 57  
coffee (structure)

 C 43  
brass oxidized (diffuser)

 C 51  
sage green (diffuser)

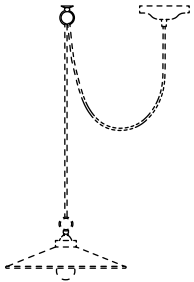

Accessory  
code  
837/d  
support for decentralization

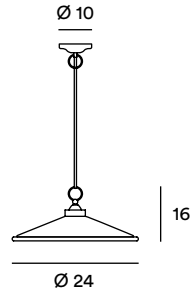

Pendant  
code  
837/22  
source  
E27 fluo/halo/led  
power  
1 x max 53W  
cable lenght  
150 cm

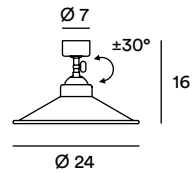

Ceiling  
code  
837/72  
source  
E27 fluo/halo/led  
power  
1 x max 53W

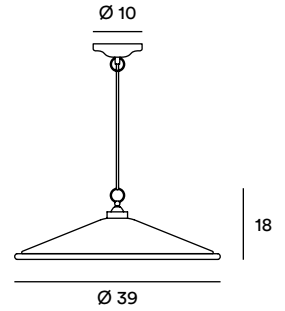

Pendant  
code  
837/24  
source  
E27 fluo/halo/led  
power  
1 x max 53W  
cable lenght  
150 cm

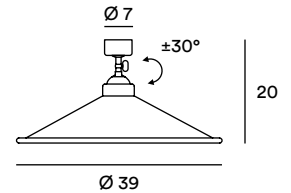

Ceiling  
code  
837/74  
source  
E27 fluo/halo/led  
power  
1 x max 53W

# Osteria

---

design Studio Gibas

---

839/24  
C43



---

839/22  
C43





839/22  
C43

Famiglia di lampade a sospensione e soffitto, in lastra di ottone ossidato di due dimensioni. Il cavo elettrico della lampada a sospensione è in tessuto intrecciato. Disponibile anche nella variante con rosone decentrato.

Collection of pendant and ceiling lamps, available in two sizes in oxidized brass. The electrical cable of the hanging lamp is in woven fabric. Also available in a decentralized variant.

Kollektion von Hänge- und Deckenleuchten aus oxidiertem Messing in zwei Größen erhältlich. Das elektrische Kabel der Hängelampe ist aus gewebtem Stoff. Auch mit dezentralisierter Abhängung erhältlich.

Série de suspensions et plafonniers en plaque en laiton oxydé de deux dimensions. Cordon d'alimentation en tissu tressé dans la version à suspension. Disponible également en version avec rosace décentré.







---

839/24+d  
C43



---

839/23  
C43

---

839/74  
C43





C 43  
brass oxidized

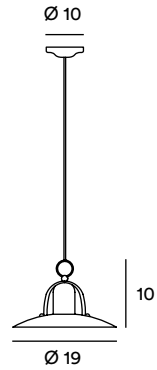

Pendant  
code  
839/22  
source  
E27 fluo/halo/led  
power  
1 x max 53W  
cable lenght  
150 cm

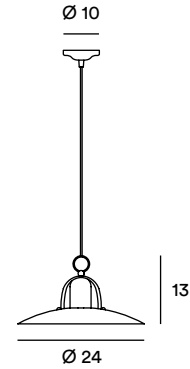

Pendant  
code  
839/23  
source  
E27 fluo/halo/led  
power  
1 x max 53W  
cable lenght  
150 cm

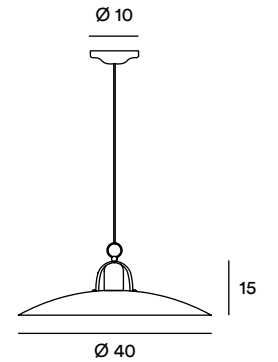

Pendant  
code  
839/24  
source  
E27 fluo/halo/led  
power  
1 x max 53W  
cable lenght  
150 cm

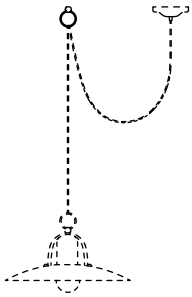

Accessory  
code  
839/d  
support for decentralization

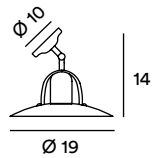

Ceiling  
code  
839/72  
source  
E27 fluo/halo/led  
power  
1 x max 53W

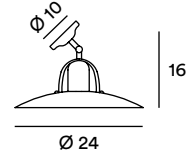

Ceiling  
code  
839/73  
source  
E27 fluo/halo/led  
power  
1 x max 53W

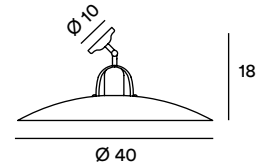

Ceiling  
code  
839/74  
source  
E27 fluo/halo/led  
power  
1 x max 53W

# Lola

---

design Studio Gibas

---

929/25-26-27  
C43+C57





---

929/27  
C43+C57

Famiglia di lampade da parete, soffitto, sospensione e terra in ottone ossidato, con dettagli in acciaio verniciato a polveri epossidiche. Nella versione a parete il diffusore è in vetro temperato bianco per l'emissione diretta ed indiretta della luce

Collection of Wall-, Floor-, Ceiling- and suspension lamps with structure in oxidized brass and details in powder coated steel. Tempered glass diffuser for direct and indirect light emission for the wall lamps.

Kollektion von Wand-, Boden-, Decken- und Hängeleuchten mit Struktur aus oxidiertes Messing und Teilen aus pulverbeschichtetem Stahl. Temperierter Glasdiffusor für direkte und indirekte Lichtemission bei den Wandlampen.

Série de suspensions, plafonniers, appliques murales et lampes sur pied en laiton oxydé avec éléments en acier peint en poudre époxy. Diffuseur en verre trempé blanc dans l'applique murale pour un éclairage direct et indirect.





---

929/75  
C43+C57









---

929/26  
C43+C57



---

929/95  
C43+C57

---

929/65  
C43+C57





C 43  
brass oxidized



C 57  
coffee (details)

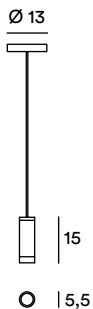

Pendant  
code  
929/25  
source  
GU10 fluo/halo/led  
power  
1 x max 10W  
cable length  
150 cm

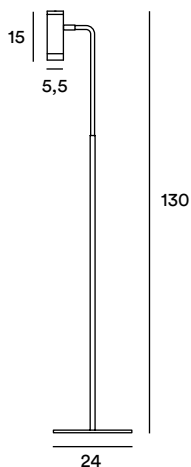

Floor  
code  
929/65  
source  
GU10 fluo/halo/led  
power  
1 x max 10W

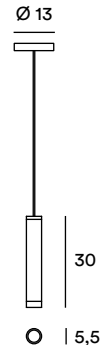

Pendant  
code  
929/26  
source  
GU10 fluo/halo/led  
power  
1 x max 10W  
cable length  
150 cm

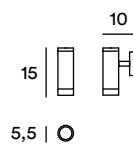

Wall  
code  
929/95  
source  
GU10 fluo/halo/led  
power  
1 x max 10W

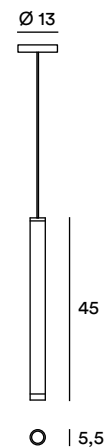

Pendant  
code  
929/27  
source  
GU10 fluo/halo/led  
power  
1 x max 10W  
cable length  
150 cm

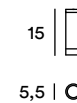

Ceiling  
code  
929/75  
source  
GU10 fluo/halo/led  
power  
1 x max 10W



---

929/41+B1  
C43+C57



929/46+929/46+B3  
C43+C57





929/41  
C43



929/46  
C43



 C 43  
brass oxidized

 C 57  
coffee (backplate)

### Accessory backplate

code  
929/B1

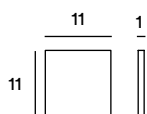

code  
929/B2

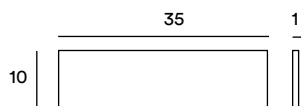

code  
929/B3

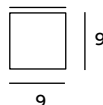
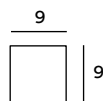
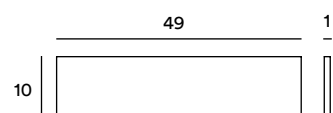

Wall  
code  
929/41  
source  
G9 fluo/halo/led  
power  
1 x max 18W

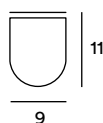
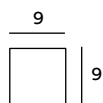

Wall  
code  
929/45  
source  
G9 fluo/halo/led  
power  
1 x max 18W

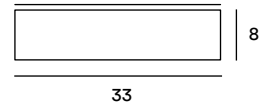
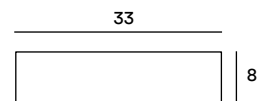

Wall  
code  
929/42  
source  
E27 fluo/halo/led  
power  
1 x max 53W

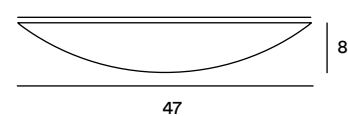
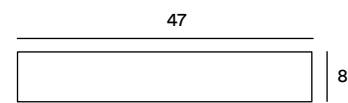

Wall  
code  
929/46  
source  
E27 fluo/halo/led  
power  
1 x max 53W

# Nio

---

design Studio Gibas





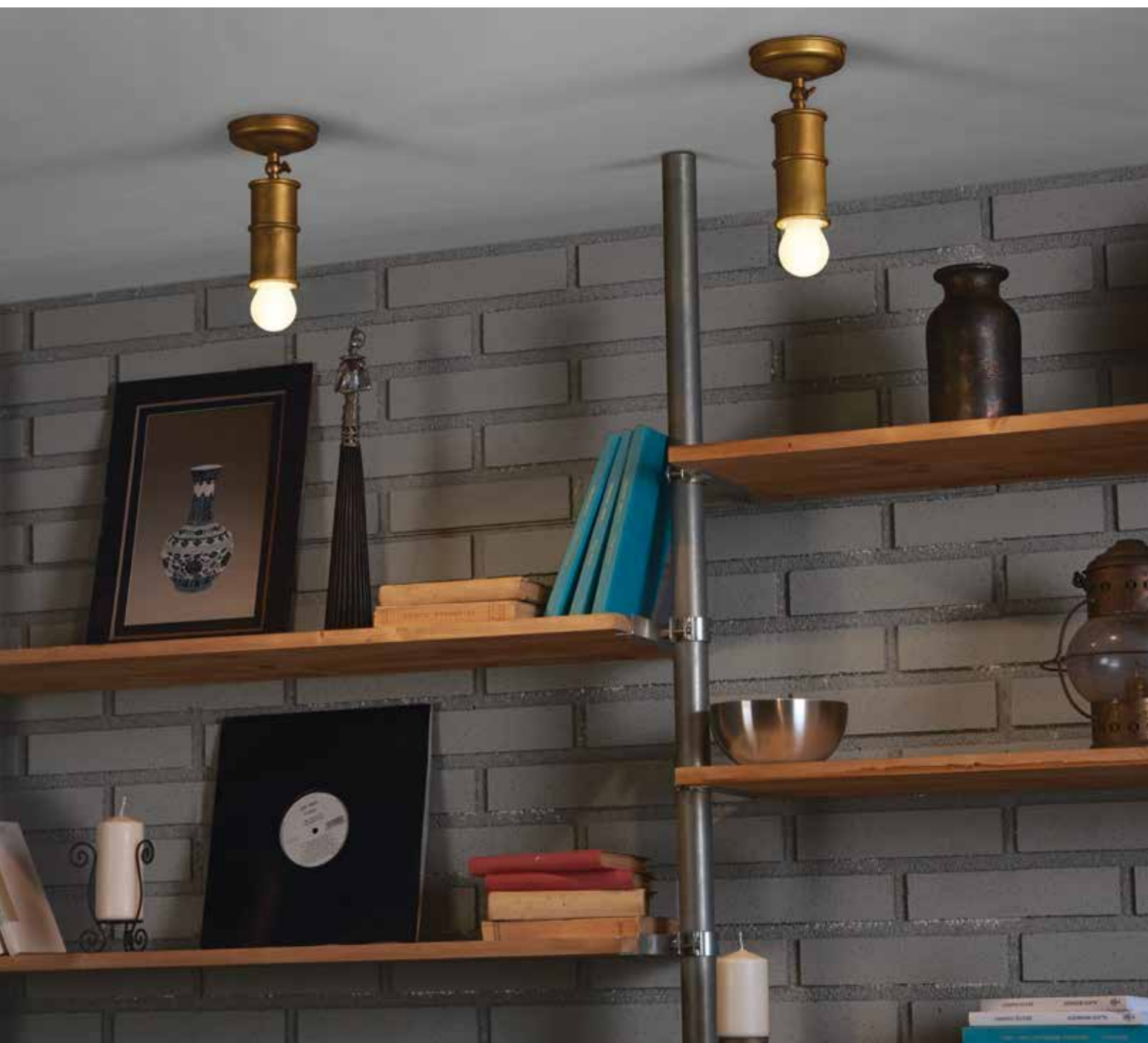

188/91  
C43

Famiglia di lampade da soffitto, sospensione e parete, con corpo tubolare in ottone ossidato. Il cavo elettrico della versione sospesa è in tessuto intrecciato, disponibile in varie dimensioni e anche con decentramento del rosone.

Collection of ceiling, suspension and wall lamps with tubular body in oxidized brass. The power cord of the suspended version is woven fabric. Available in various sizes and even in a decentralized version.

Kollektion von Decken-, Hänge-, und Wandleuchten mit röhrenförmigen Gestell aus oxidiertem Messing. Das Stromkabel der Hängeleuchte ist aus Stoff. Erhältlich in verschiedenen Größen und auch mit dezentralisierter Abhängung.

Série de plafonniers, suspensions et appliques murales avec corps tubulaire en laiton oxydé. Cordon d'alimentation de la version à suspension en tissu tressé. Disponible en différentes dimensions et également avec décentralisation de la rosace.





188/14  
C43





188/24  
C43

188/42  
C43





C 43  
brass oxidized

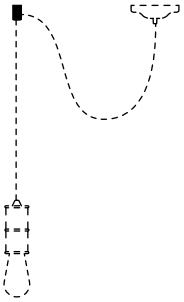

Accessory  
code  
188/d  
support for decentralization



Pendant  
code  
188/23  
source  
E27 fluo/halo/led  
power  
1 x max 53W  
cable length  
150 cm

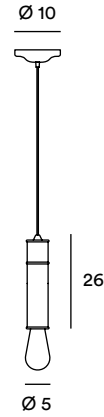

Pendant  
code  
188/24  
source  
E27 fluo/halo/led  
power  
1 x max 53W  
cable length  
150 cm

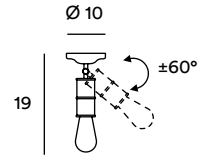

Wall-Ceiling  
code  
188/91  
source  
E27 fluo/halo/led  
power  
1 x max 53W

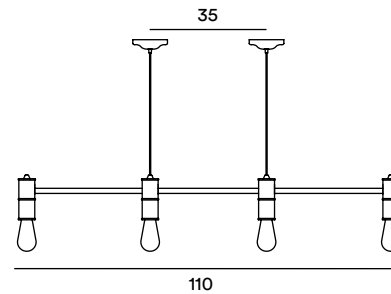

Pendant  
code  
188/14  
source  
E27 fluo/halo/led  
power  
4 x max 53W  
cable length  
150 cm

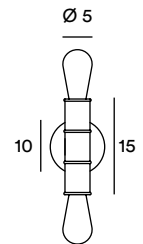

Wall-Ceiling  
code  
188/42  
source  
E27 fluo/halo/led  
power  
2 x max 53W



**Agò**

design LT DESIGN





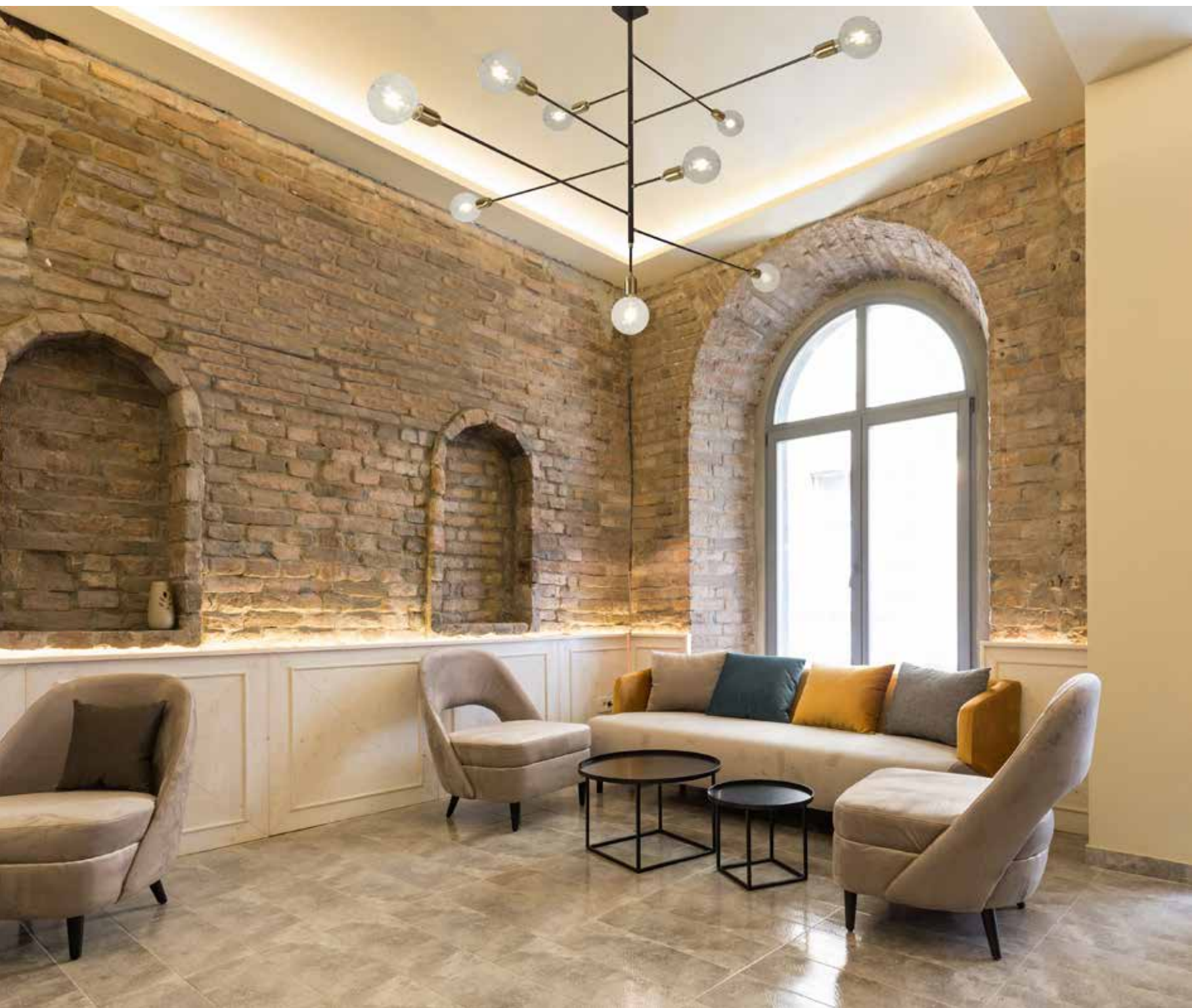



Famiglia di lampade da soffitto e parete realizzata con tubi in metallo verniciato a polveri epossidiche e decorato a mano. I dettagli sono in ottone spazzolato.

Collection of ceiling and wall lamps made of epoxy powder coated metal tubes and decorated by hand. The details are in brushed brass.

Kollektion von Decken- und Wandleuchten aus mit Epoxidharz pulverbeschichteten Metallrohren, die von Hand dekoriert sind. Die Details sind in gebürstetem Messing.

Série de plafonniers et appliques murales en tubes en métal peint en poudre époxy et décoré à la main. Détails en laiton brossé.

---

103/19  
C28

---

103/16  
C28





103/75  
C28







103/84  
C28





103/42  
C28



103/76  
C29





C 28  
golden brown



C 29  
golden ivory



C 41  
brushed brass (details)

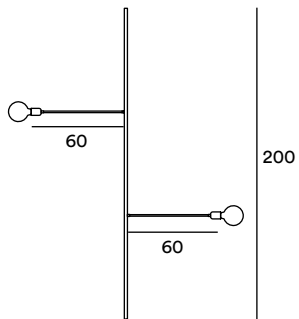
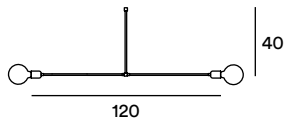

Ceiling  
code  
103/84  
source  
E27 fluo/halo/led  
power  
2 x max 53W

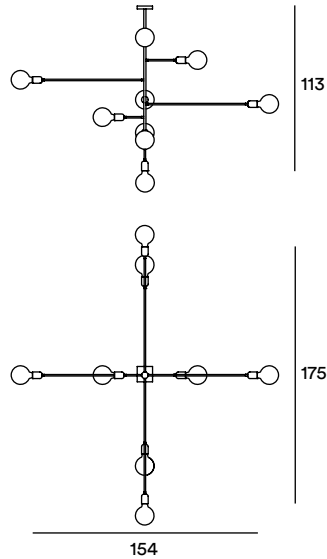

Chandelier  
code  
103/19  
source  
E27 fluo/halo/led  
power  
9 x max 53W

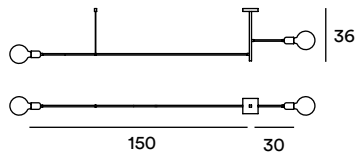

Pendant  
code  
103/73  
source  
E27 fluo/halo/led  
power  
2 x max 53W

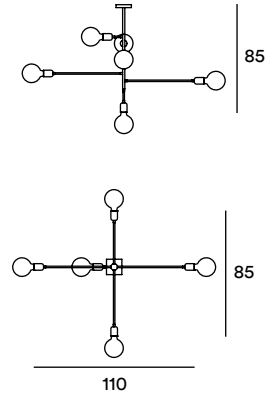

Chandelier  
code  
103/16  
source  
E27 fluo/halo/led  
power  
6 x max 53W

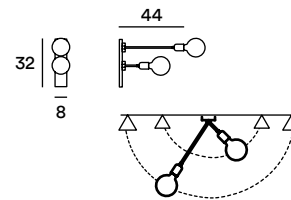

Wall  
code  
103/42  
source  
E27 fluo/halo/led  
power  
2 x max 53W

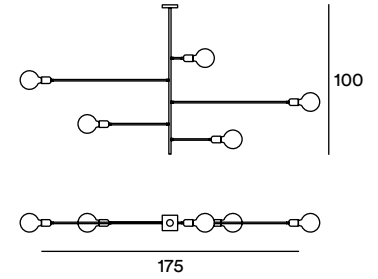

Ceiling  
code  
103/75  
source  
E27 fluo/halo/led  
power  
5 x max 53W

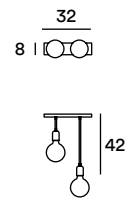

Ceiling  
code  
103/76  
source  
E27 fluo/halo/led  
power  
2 x max 53W



COLOR

COLORE



# COLOR CODES

## CODICI COLORE

---

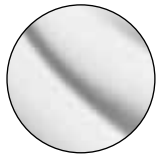

C 1  
white opaque  
bianco opaco



C 2  
black opaque  
nero opaco

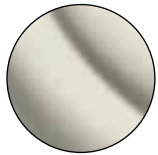

C 7  
ivory  
avorio



C 13  
copper  
rame



C 27  
bronze  
bronzò



C 28  
golden brown  
marrone dorato



C 29  
golden ivory  
avorio dorato



C 35  
concrete  
cemento



C 36  
corten  
corten



C 41  
brushed brass  
ottone spazzolato

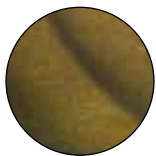

C 43  
brass oxidized  
ottone ossidato

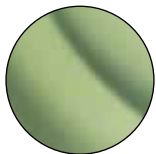

C 51  
sage green  
verde salvia



C 57  
coffee  
caffè

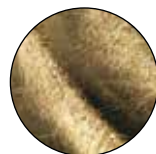

C 60  
goldfoil  
foglia oro



C 69  
aluminum  
alluminio



C 74  
sand black  
nero sabbia



C 75  
silverfoil  
foglia argento

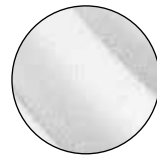

C 80  
sand white  
bianco sabbia

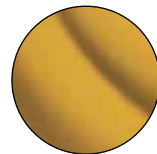

C 84  
coated gold  
oro patinato



C 89  
milk & honey  
latte e miele

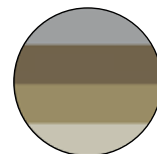

C 91  
storm  
burrasca

The colour-code under each image is related to the colour of the photographed article. The available standard colours are shown on the last page of each series. The colours of the illustrated articles are reproduced the most faithfully possible, in line with the technical limits of printing and small variations of tone are possible, due to the handcraft making.



Graphic Design  
Margherita Giacomozzi

Elena Salusti

Photo  
Andrea Bellezza

Printing

Bieffe

Credits

Giorgio Vallorani

Giorgio Tassi

Pirovano

[www.gibas.it](http://www.gibas.it)

HQ & flagship store

Facebook - Instagram - Twitter