

ALMA light  
Barcelona

Catálogo general  
*General catalogue*  
2020 - 2021



ALMA light  
Barcelona

# Quién es

Josep Novell (Barcelona 1953)

Oriol Llahona (Barcelona 1977)

Ernest Perera (Barcelona 1974)

Jordi Llopis (Barcelona 1972)



## Josep Novell.

Estudia Diseño de Producto en ELISAVA (Escuela Universitaria de Diseño e Ingeniería de Barcelona), y posteriormente se gradúa en Bachelor of Arts por la University of Southampton (Reino Unido). Desde 1980 se dedica al diseño, tanto desde su propio estudio como en colaboración con otros diseñadores. En 1984 funda la empresa "Via Design", junto con Joan Suñol, proyecto que finaliza en 1988. Posteriormente crea "Novell/Puig Design" junto con el diseñador Josep Puig. Además, desde 1984 imparte clases como profesor de proyectos en la Escuela Superior de Diseño ELISAVA. Es miembro de la Asociación de Diseño Industrial del Foment de les Arts i del Disseny (ADI-FAD). Para ALMA LIGHT, conjuntamente con los diseñadores Josep Puig y Ernest Perera, ha desarrollado luminarias clásicas de la marca, como las colecciones BLOW, FLAT, MOON, ORB, ROOM, STONE, SUN y TINY.

Josep Novell está particularmente interesado en relacionar estrechamente tres conceptos: forma, material y proceso de fabricación. Además tiene muy en cuenta aspectos más intangibles del producto como la comunicación, la emoción o la ética. Sus diseños están presentes en ámbitos tan diferentes como la iluminación, el packaging, el diseño de producto, el mobiliario o la imagen corporativa. Josep Novell es uno de los grandes diseñadores de nuestro país, y muchas de sus creaciones han sido galardonadas y expuestas en ferias y certámenes de diseño en Europa, Estados Unidos y Asia.

## Oriol Llahona.

Estudia Diseño Industrial en, Barcelona, Alemania y Reino Unido. Se gradúa en

1999 y obtiene su postgrado en 2004. Después de trabajar en diversas empresas y estudios de diseño, en 2004 crea su propio proyecto llamado "Llahona Design Studio" en el cual desarrolla su visión cosmopolita, contemporánea y positiva del diseño, la búsqueda de la esencia y las emociones en nuestra vida. En 2012 es llamado a unirse a Philips, diseñando luminarias de origen y asumiendo su Dirección Creativa. Actualmente trabaja en varios proyectos en Europa, América y Asia que incluyen diseños de iluminación, muebles y electrónica de consumo. Para ALMA LIGHT ha desarrollado luminarias que ya se han convertido en clásicos, como las colecciones BATH, BIG BROTHER, CAPITONÉ, MADAME, NOTE, PROFILE, SPIKE y SUIT.

Oriol Llahona es un diseñador nato, curioso y de mente abierta, su estilo es una mezcla de búsqueda de nuevos materiales y tecnologías con un sereno y refinado sentido de las formas. Sus diseños abarcan ámbitos tan diversos como la iluminación, el packaging, el diseño de producto, los espacios de restauración, el mobiliario. Muchas de sus creaciones han sido expuestas en salones de Italia, Alemania y Japón y han sido seleccionadas para diversas publicaciones sobre diseño internacional.

## Ernest Perera.

Ernest Perera combina sus estudios de escultura en la Facultad de Bellas Artes de la Universidad de Barcelona con los de Diseño Industrial en la Escuela ELISAVA (Escuela Universitaria de Diseño e Ingeniería) de la misma

ciudad.

Funda su propio estudio en 1999, donde diseña productos y experiencias para ayudar a las empresas a ser más competitivas, desde piezas únicas a elementos altamente seriados. Sus trabajos se caracterizan por proporcionar conceptos renovados en cada proyecto, aportando soluciones específicas para cada caso. En 2006 crea "Amor de Madre", su propia empresa editora de productos para el hogar, la cual le permite imprimir su libertad de creación y de experimentación en diversos productos del ámbito del hogar. Desde 1998 es docente en varias universidades de diseño de Barcelona. Actualmente es el Jefe de Área de Diseño de Productos en la escuela LCI Barcelona.

Ha colaborado con empresas como Camper, Lékué, Delica, Mago Urban, Alma Light –donde desarrolla junto a Josep Novell las colecciones BLOW, FLAT, MOON, ORB, PILL y SQUARE--, Museo Picasso de Barcelona, Rumitag, Artesanía de Cataluña o el ADI-FAD. Ha recibido diversos galardones, como una selección a los Premios DELTA de Diseño ADI-FAD, Barcelona (2009) y el primer premio en el certamen internacional Les Découvertes, Maison Objet, París (2008).

Sus creaciones han sido expuestas en galerías de todo el mundo y han sido seleccionadas para diversas publicaciones sobre diseño internacional.

## Jordi Llopis.

Se forma como diseñador en la Escuela ELISAVA de Barcelona y en el "Royal College of Art" de Londres.

Diseñador Industrial, ha trabajado como Design Manager en empresas de iluminación, llevando a cabo la dirección de nuevos productos e identidad corporativa. Lleva años colaborando con empresas de iluminación, mobiliario urbano y objetos para el hogar. 'Lifelight', lámpara creada por él en 2003, forma parte de la colección permanente del 'Museu del Disseny' de Barcelona, y su lámpara 'Clipa'm' fue seleccionada en los Premios Delta 2016.

Actualmente dirige su propio estudio de diseño llamado Jordi Llopis Design, en Barcelona, y es co-fundador de la editora Brots. Trabaja desarrollando nuevos diseños para el mundo de la iluminación y elementos urbanos, así como diseñando y produciendo sus nuevas colecciones para Brots. La excusa es diseñar para uno mismo como autoencargo, sin premisas ni filtros previos, para poder llegar a un producto muy personal, original y coherente que ofrecer. Esta es parte de la filosofía que se quiere transmitir en Brots. Jordi Llopis colabora, además, como profesor externo en ESDI, Escuela Superior de Diseño de Barcelona y ELISAVA Alumni y es tutor en el Máster de ESdesign Barcelona. Ha sido jurado en los Premios Eil de ELISAVA de Barcelona, y ha impartido talleres en la Universidad de Aguascalientes en México y en ELISAVA.

# Who is

Jordi Llopis (Barcelona 1972) Ernest Perera (Barcelona 1974) Oriol Llahona (Barcelona 1977) Josep Novell (Barcelona 1953)



**Ernest Perera.**

He combined his studies of sculpture in the Faculty of Fine Arts of the University of Barcelona with those of Industrial Design in ELISAVA (University School of Design and Engineering) of the same city. He founded his own studio in 1999, where he designed products and experiences to help companies become more competitive, from unique pieces to highly serialized elements. His works are characterized by providing renewed concepts in each project, bringing specific solutions for each case. In 2006, he created "Amor de Madre", his own company for home products, which allows him to develop his freedom of creation and experimentation on various household products. Since 1998 he has been teaching at several design universities in Barcelona. He is currently the Head of Product Design at LCI Barcelona School.

He has collaborated with companies such as Camper, Lékué, Delica, Mago Urban, ALMA LIGHT - where he developed, together with Josep Novell, the collections BLOW, FLAT, MOON, ORB, PILL and SQUARE--, Barcelona Picasso Museum, RumiTag, Artesanía de Cataluña or the ADI-FAD. He has received several awards, such as a selection at the DELTA Design Awards ADI-FAD, Barcelona (2009) and the first prize at the international competition Les Découvertes, Maison Objet, Paris (2008). His creations have been exhibited in galleries around the world and have been selected for various publications on international design.

**Jordi Llopis**

was formed as a designer at the ELISAVA School in Barcelona and at the 'Royal College of Art' in London.

Industrial Designer, he has worked as a Design Manager in lighting companies carrying out the direction of new products and corporate identity. He has been collaborating with lighting companies, street furniture and household items for years. 'Lifelight', a lamp created by him in 2003, is part of the permanent collection of the 'Museu del Disseny' of Barcelona, and the 'Clipa'm' lamp was selected in the Delta 2016 Awards.

He currently directs his own design studio called Jordi Llopis Design, in Barcelona, and is co-founder of the editing company Brots. He works developing new designs in the world of lighting and urban elements, as well as designing and producing new collections for Brots. The excuse is to design for oneself on self-request, without prejudices or previous filters, in order to arrive at a very personal, original and coherent product to offer. This is part of the philosophy that to be transmitted by Brots. Jordi Llopis also collaborates as an external teacher at ESDI, Barcelona School of Design and ELISAVA Alumni and is Tutor in the ESdesign Barcelona Master. He has been a jury at the Ei Awards! of ELISAVA in Barcelona, and has collaborated in workshops at the University of Aguascalientes in Mexico and in ELISAVA.

**Oriol Llahona.**

He studied Industrial Design in Barcelona, Germany and the United Kingdom. He graduated in 1999 and obtained his postgraduate degree in 2004.

After working in various companies and design studios, in 2004 he created his own project called "Llahona Design Studio" in which he developed his cosmopolitan, contemporary and positive vision of design, the pursuit of essence and emotions in our life. In 2012 he was called to join Philips, designing light fixtures and undertaking his Creative Direction. He is currently working on several projects in Europe, America and Asia including lighting designs, furniture and consumer electronics. For ALMA LIGHT has developed luminaires that have already become classics, such as BATH, BIG BROTHER, CAPITONÉ, MADAME, NOTE, PROFILE, SPIKE and SUIT. Oriol Llahona is a born designer, curious and open-minded, his style is a mixture of searching for new materials and technologies with a serene and refined sense of forms. His designs cover areas as diverse as lighting, packaging, product design, dining spaces, furniture. Many of his creations have been exhibited in salons in Italy, Germany and Japan. They have also been selected for various publications on international design

Josep Novell is particularly interested in closely relating three concepts: form, material and manufacturing process. He also takes into account more intangible aspects of the product such as communication, emotion or ethics. His designs are present in areas as different as lighting, packaging, product design, furniture or corporate image. Josep Novell is one of the great designers of our country, and many of his creations have been awarded and exhibited in fairs and design contests in Europe, the United States and Asia.

**Josep Novell.**

He studied Product Design at ELISAVA (School of Design and Engineering of Barcelona) and he later graduated as Bachelor of Arts at the University of Southampton (United Kingdom).

Since 1980 he has been dedicated to design, both from his own studio and in collaboration with other designers.

In 1984 he founded the company "Via Design, SA" together with Joan Suñol, a project that ended in 1988. He later created "Novell / Puig Design" together with the designer Josep Puig. In addition, since 1984 teaches as a professor of projects in the School of Design ELISAVA. He is a member of the Industrial Design Association of the Foment de les Arts i del Disseny (ADI-FAD). In ALMA LIGHT, together with the designers Josep Puig and Ernest Perera, he has developed classic luminaires of the brand such as the collections BLOW, FLAT, MOON, ORB, ROOM, STONE, SUN and TINY.

Josep Novell is particularly interested in closely relating three concepts: form, material and manufacturing process. He also takes into account more intangible aspects of the product such as communication, emotion or ethics. His designs are present in areas as different as lighting, packaging, product design, furniture or corporate image. Josep Novell is one of the great designers of our country, and many of his creations have been awarded and exhibited in fairs and design contests in Europe, the United States and Asia.

# Ilumínate

Obj (Barcelona 2007)

Josep Puig (Barcelona 1959)

Cristian Cubiñá (Barcelona 1968)

Alfonso de la Fuente (Valladolid 1974)



## Obj ( Javier Taberner & Nacho Poveda )

Nace en 2007 de la unión de sus dos socios: Javier Taberner y Nacho Poveda. Sus diseños de mobiliario, producto e iluminación han sido reconocidos con numerosos premios y distinciones, habiendo sido difundidos en publicaciones especializadas a nivel internacional. El estudio también ha participado en distintas exposiciones y eventos en diferentes ciudades de Iberoamérica, Londres, Madrid, Milán, Barcelona, Saint Étienne, etc.

## Josep Puig

Estudia Diseño Industrial en ELISAVA (Escuela Universitaria de Barcelona Diseño e Ingeniería) y obtiene el título en 1980. Posteriormente amplía su formación en la University of Southampton (Reino Unido) donde se gradúa con honores como Bachelor of Arts. Es miembro de la Asociación de Diseño Industrial del Fomento de las Artes y el Diseño ADI-FAD y ha formado parte de la Junta de la Asociación en diversas ocasiones. Ha impartido cursos y talleres en numerosos foros de diseño y actualmente es profesor en la Escuela Superior de Diseño ELISAVA, donde dirige el Máster en Diseño y Desarrollo de Producto en ELISAVA desde 2006. Josep Puig es un diseñador inquieto y brillante cuya creatividad se ha desarrollado en multitud de ámbitos. Entre otras muchas iniciativas, es miembro fundador del grupo de diseño experimental "Transatlàntic" junto a Ramón Benedito y Lluís Morillas. En 1989 se embarca en el proyecto "The Barna Crossing in Fukuoka" con Alfredo Arribas Arquitectos Asociados, para el diseño de una colección de objetos para un complejo multimedia en Fukuoka (Japón). Durante su trayectoria profesional

ha recibido numerosos premios y distinciones de organismos españoles e internacionales. Junto al diseñador Josep Novell funda en 1992 el estudio "Novell/Puig Design", orientado al diseño y desarrollo de productos. En 2010 crea su propio estudio "Puig[i]Cabeza Design". Para ALMA LIGHT ha desarrollado, junto con Josep Novell, colecciones de luminarias ya clásicas de la marca como STONE, SUN y TINY. Sus diseños, numerosos de ellos premiados en certámenes nacionales e internacionales, abarcan áreas tan variadas como los artículos sanitarios, gafas, packaging, cerámica y vidrio, electrodomésticos, mobiliario, iluminación y menaje del hogar.

## Cristian Cubiñá

Estudia Diseño Industrial en la Escuela ELISAVA (Escuela Universitaria de Diseño e Ingeniería) de Barcelona y una vez finaliza su formación decide crear su proyecto empresarial, fundando la sociedad familiar "Hustadt Iluminación". Durante los primeros años asume las responsabilidades de Jefe de Producto. En 2003, momento en que la compañía crea la marca ALMA LIGHT, se responsabiliza de áreas más amplias como diseño de producto, selección de proveedores de proximidad y control de la fabricación y de sus estándares de máxima calidad, siempre con la vista puesta en la continua evolución del mercado, tanto en términos de diseño como en aspectos puramente tecnológicos y productivos. Es en el proyecto ALMA LIGHT donde Cristian Cubiñá puede desarrollar sus dotes de diseñador, proyectando los stands de las ferias a las que la empresa acude como expositora, y creando colecciones ya clásicas como la DROP o la LENS. Más adelante firmará otras

creaciones, como las familias CANDLE, CAPSULE, DECO, HOTEL, KONE, LED BOX, LED OVAL, LED POLE, THE LIGHT y THE PALM. Sus diseños están impregnados de su carácter curioso y observador y en su afán por fijarse en todo lo que ve a su alrededor, donde cualquier detalle puede ser susceptible de convertirse en una luminaria.

Cristian Cubiñá es uno de los diseñadores más reputados en el campo de la iluminación decorativa contemporánea, sector en el cual está especializado. Sus creaciones han sido expuestas en diversas ferias europeas y han sido seleccionadas para diversas publicaciones sobre diseño internacional.

## Alfonso de la Fuente (Pichiglas Studio)

Afincado en Barcelona desde 1997, Alfonso de la Fuente ha ido evolucionando como artista autodidacta, aportando aires de renovación al panorama del diseño en el ámbito de la decoración a base de trabajo, talento, pasión e imaginación. Después de que su llegada a Barcelona le descubriese el reciclaje del plástico, Pichiglas empieza a reutilizar botellas de consumo masivo para crear objetos, creando su primer aparato de iluminación decorativa en 1997. Pichiglas se desarrolla entonces a gran velocidad gracias a la continua creatividad, a la pasión y al trabajo, produciendo siempre con humor, ironía y color, y convirtiéndose en participe de esa Barcelona tan de moda de los primeros años del siglo XXI en la que todo era posible. Después de cosechar un notable éxito con su línea de objetos decorativos y accesorios, el diseñador decide incluir en sus intereses el interiorismo integral para la decoración de bares de moda, restaurantes, comercios, locales y clubs, algunos convertidos ya en grandes clásicos como la discoteca barcelonesa FONFONE. El trabajo de Pichiglas Studio se da a conocer ya no sólo a nivel nacional, sino que empieza a recibir encargos de países como Francia e Italia. Lo que diferencia a Pichiglas Studio del resto de diseñadores es, precisamente, su capacidad para hacer de las texturas, los materiales y los objetos cotidianos verdaderas combinaciones de efectos visuales que no dejan a nadie indiferente. En una época en la que triunfa el minimalismo, Alfonso de la Fuente y Pichiglas Studio, revolucionan la decoración de los espacios con un denominador común: explosión de color combinada con una sorprendente simplicidad conceptual que consiguen un resultado de alto poder expresivo. En palabras del propio diseñador, "Hoy en día, tenemos que contar cosas cuando creamos, sorprender y chocar, pero sin perder nuestra esencia, aquello que nos define"

# Light up

Alfonso de la Fuente (Valladolid 1974) Cristian Cubiñá (Barcelona 1968)

Josep Puig (Barcelona 1959)

Obj (Barcelona 2007)



DROP or LENS. Later, he signs other creations such as CANDLE, CAPSULE, DECO, HOTEL, KONE, LED BOX, OVAL LED, LED POLE, THE LIGHT and THE PALM. His designs are imbued with his curious and observant character and his eagerness to look at everything he sees around him, where any detail can be susceptible of becoming a light fitting.

Cristian Cubina is one of the most renowned designers in the field of contemporary decorative lighting, a sector in which he is specialized. His creations have been exhibited at various European fairs and have been selected for several publications on international design.

#### Alfonso de la Fuente (Pichiglas Studio)

Based in Barcelona since 1997, Alfonso de la Fuente has evolved as a self-taught artist, bringing renewal airs to the design environment in the field of decoration based on work, talent, passion and imagination.

After his arrival in Barcelona, when finding out more about the recycling of plastic, Pichiglas begins to reuse bottles of mass consumption to create objects, designing his first decorative lighting fixture in 1997. Pichiglas develops then at high speed thanks to his continuous creativity, passion and work, always producing with humor, irony and color, and becoming a participant in that fashionable Barcelona of the first years of the 21st century in which everything was possible.

After reaping a remarkable success with his line of decorative objects and accessories, the designer decides to include in his interests the integral interior design for the decoration of trendy bars, restaurants, shops, stores and clubs, some of which have already become great classics such as the Barcelona disco FONFONE. The work of Pichiglas Studio is already known not only nationally, but begins to receive orders from countries such as France and Italy. What sets Pichiglas Studio apart from other designers is precisely its ability to make textures, materials and everyday objects true combinations of visual effects that leave no one indifferent. In an era in which minimalism triumphs,

Alfonso de la Fuente and Pichiglas Studio revolutionize the decoration of spaces with a common denominator: explosion of color combined with a surprising conceptual simplicity that achieve a result of high expressive power.

In the words of the designer himself: "Today, we have to tell things when we create, we must surprise and collide, but without losing our essence, what defines us."

Japan. During his professional career he has received numerous awards and distinctions from Spanish and international organizations. Together with the designer Josep Novell founded in 1992 the study "Novell / Puig Design", oriented to the design and development of products. In 2010 he created his own studio "Puig [i] Cabeza Design". For ALMA LIGHT has developed, along with Josep Novell, collections of classic luminaires of the brand as STONE, SUN and TINY.

Its designs, many of them awarded in national and international competitions, cover areas as varied as sanitary ware, glasses, packaging, ceramics and glass, household appliances, furniture, lighting and household items.

#### Cristian Cubiñá.

He studies Industrial Design at the ELISAVA School (University School of Design and Engineering) in Barcelona and, once he finishes his training, he decides to create his own business project, founding the family society "Hustadt Iluminación".

During the first years he undertakes the responsibilities of Product Manager.

In 2003, when the company creates the ALMA LIGHT brand, he becomes responsible for broader areas such as product design, selection of proximity suppliers and control of manufacturing and its highest quality standards, always with a view to the evolution of the market, both in terms of design and purely technological and productive aspects. It is in the ALMA LIGHT project that Cristian Cubina can develop his skills as a designer, projecting the stands of the fairs in which the company participates as exhibitor and creating classic collections, such as

#### Obj ( Javier Taberner & Nacho Poveda )

Studio borned in 2007 from the union of his two partners: Javier Taberner and Nacho Poveda. Their designs of furniture, product and lighting have been recognized with numerous prizes and distinctions in specialized publications, having spread to an international level. The studio also has participated in different exhibitions and events in different cities of Ibero-America, London, Madrid, Milan, Barcelona, Saint Etienne, etc.

#### Josep Puig Cabeza.

He studied Industrial Design at ELISAVA (Escuela Universitaria de Barcelona Diseño y Ingeniería) and obtained his degree in 1980. He later completed his degree at the University of Southampton (UK) where he graduated with honors as a Bachelor of Arts. He is a member of the Industrial Design Association of the Promotion of Arts and Design ADI-FAD and has been part of the Board of the Association on several occasions. He has taught courses and workshops in numerous design forums and is currently a professor at ELISAVA, where he has been leading the Master in Design and Product Development since 2006.

Josep Puig is a restless and brilliant designer whose creativity has developed in many areas. Among other initiatives, he is a founding member of the experimental design group "Transatlàntic" with Ramón Benedito and Lluís Morillas. In 1989 he embarked on the project "The Barna Crossing in Fukuoka" with "Alfredo Arribas Arquitectos Asociados", for the design of a collection of objects for a multimedia complex in Fukuoka,

Luminarias USB  
USB Lamps

12-41







Sobremesas  
*Table Lamps*



Lámparas de pie  
*Floor Lamps*

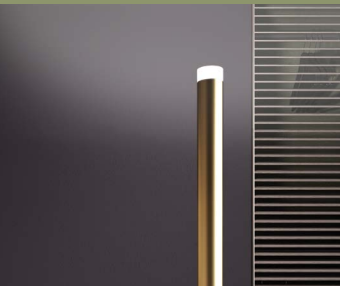
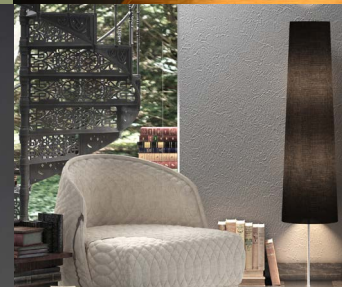

Suspensión  
*Hanging Lamps*

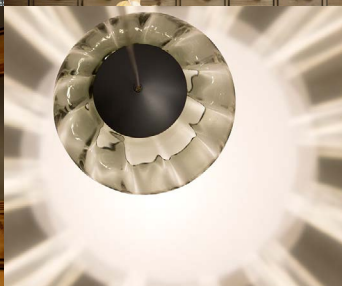















Exterior  
*Outdoor*



































274-287



































 **Luminarias USB / USB Lamps** ..... 12

|                      |    |   |
|----------------------|----|---|
| Bell .....           | 28 |     |
| Cuadrat .....        | 32 |    * |
| MiniBigbrother ..... | 18 |     |
| Nautic .....         | 38 |    * |
| Patio .....          | 20 |   *   |
| Tribeca USB .....    | 14 |     |



















 **Sobremesas / Table Lamps** ..... 42

|                       |    |   |
|-----------------------|----|---|
| Aspen .....           | 76 |    |
| Blow .....            | 70 |      |
| Candle .....          | 66 |    |
| Capsule .....         | 62 |      |
| CapsuleHat.....       | 60 |      |
| Deco .....            | 64 |     |
| Fuji.....             | 44 |      |
| Hotel .....           | 68 |      |
| Note .....            | 74 |      |
| Paros Alabaster ..... | 56 |      |
| Star.....             | 52 |     |
| Tribeca.....          | 48 |     |

































 **Lámparas de pie / Floor Lamps** ..... 78

|                       |     |   |
|-----------------------|-----|---|
| Big Brother.....      | 100 |    |
| Blow .....            | 98  |      |
| Capsule .....         | 94  |      |
| CapsuleHat.....       | 92  |      |
| Deco .....            | 106 |             |
| Fuji.....             | 80  |      |
| Hotel .....           | 104 |      |
| Led Pole .....        | 98  |    |
| Note .....            | 96  |      |
| Paros Alabaster ..... | 90  |      |
| Star.....             | 88  |     |
| Tribeca.....          | 84  |     |
| Work .....            | 108 |    |







 **Suspensión / Hanging Lamps** ..... 110

















|                 |     |   |
|-----------------|-----|---|
| Bath A Led..... | 190 |      |
| Biscuit .....   | 196 |    |
| Blow .....      | 168 |      |
| Capsule .....   | 158 |      |
| CapsuleHat..... | 156 |      |
| Deco .....      | 166 |     |
| Double .....    | 208 |    |

# Indice. Index.





























|                       |     |   |
|-----------------------|-----|---|
| Drop .....            | 202 |     |
| Fuji .....            | 124 |      |
| Led Box .....         | 178 |    |
| Led Oval .....        | 182 |    |
| Lens .....            | 192 |     |
| Moon .....            | 160 |      |
| Paros Alabaster ..... | 134 |      |
| Soft .....            | 148 |    |
| Spike .....           | 164 |  *   |
| Stone .....           | 198 |    *   |
| Sun .....             | 200 |      |
| SuperMoon .....       | 162 |     |
| TheChandelier .....   | 112 |    |
| TheLight .....        | 144 |    |
| ThePalm .....         | 136 |    |
| Tribeca.....          | 128 |      |

## **Plafón / Ceiling Lamps**..... 210

|                      |     |   |
|----------------------|-----|---|
| Bath A.....          | 230 |    |
| Deco .....           | 218 |     |
| Drop S .....         | 214 |     |
| Drop Downlight ..... | 240 |    |
| Lens .....           | 234 |     |
| Mizu .....           | 232 |     |

|                 |     |   |
|-----------------|-----|---|
| Moon .....      | 220 |      |
| Stone .....     | 228 |    *   |
| Sun .....       | 238 |      |
| SuperMoon ..... | 224 |     |
| Tribeca.....    | 212 |      |

## **Apliques / Wall Lamps** ..... 242

|                       |     |   |
|-----------------------|-----|---|
| Bath A Led .....      | 264 |      |
| Deco .....            | 258 |           |
| Flat Led.....         | 254 |    |
| Hotel .....           | 262 |      |
| Madame .....          | 270 |    |
| MiniFlat.....         | 256 |    |
| Mizu .....            | 268 |     |
| Note .....            | 266 |      |
| Paros Alabaster ..... | 252 |      |
| Square .....          | 260 |    |
| Tribeca.....          | 244 |      |

## \* **Exterior / Outdoor** ..... 274

|                 |     |   |
|-----------------|-----|---|
| Spike .....     | 276 | *    |
| Stone Out ..... | 284 | *    |
| Tiny .....      | 280 | *   |

# Luminarias USB

# USB Lamps

Bell / Cuadrat / Mini Big Brother / Nautic / Patio / Tribeca USB









## Tribeca USB

Design by Jordi Llopis

Estructura hierro galvanizado pintado epoxi texturado  
**Structure galvanized iron textured epoxy painted**

Pantalla alabastro  
**Shade alabaster**

Luminaria con batería de polímero de litio. Autonomía 7h, carga completa 5h. Cargador USB no incluido (ver referencias abajo).

Lámpara incluida, no reemplazable. ON/OFF/Touch dimmer  
**Lithium polymer battery 7h autonomy. Complete charge 5h. USB charger not included (See codes below). Lamp included, not replaceable. ON/OFF/Touch Dimmer**

1800/011 24cm blanco **white**

1800/012 24cm corten **corten**

1800/018 24cm negro **black**

1810/011 20cm blanco **white**



1810/012 20cm corten **corten**

1810/018 20cm negro **black**

LED 1,3W 3000K 150lm

9995/010 Cargador USB simple 5V 1.5A + 1,5mt cable  
**Single 5V 1.5A charger + 1.5m USB cable**

9996/060 Cargador múltiple 6 x USB 5V 1.5A + 1,5mt cable  
**Multiple charger 6 x 5V 1.5A + 1.5m cable**

CE   

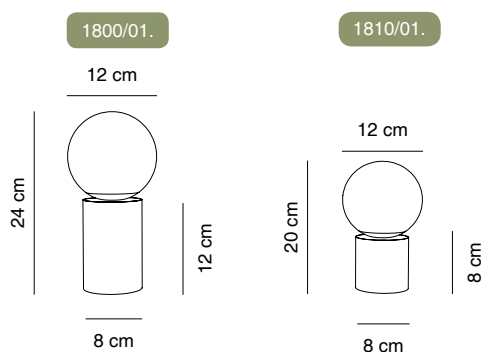







## Mini BigBrother

Design by Oriol LLahona

Estructura hierro galvanizado pintado epoxi texturado  
**Structure textured epoxi painted galvanized steel**

Pantalla polietileno PETG  
**Shade PETG polyethylene**

Luminaria con batería de polímero de Litio. Autonomía 7h, carga completa 5h. Cargador USB no incluido (ver referencias abajo). Lámpara incluida, no reemplazable. ON/OFF/Touch dimmer  
**Lithium polymer battery 7h autonomy. Complete charge 5h. USB charger not included (See codes below). Lamp included, not replaceable. ON/OFF/Touch Dimmer**

2090/011 blanco **white**

2090/011 negro **black**

2090/015 rojo **red**

LED 1,3W 3000K 150lm

9995/010 Cargador USB simple 5V 1.5A + 1,5mt cable  
**Single 5V 1.5A charger + 1.5m USB cable**

9996/060 Cargador múltiple 6 x USB 5V 1.5A + 1,5mt cable  
**Multiple charger 6 x 5V 1.5A + 1.5m cable**

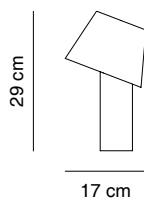

CE  IP45  A+

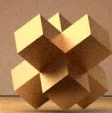







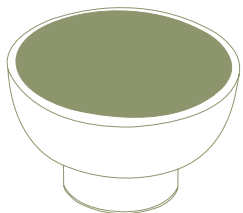

**Elegante / Funcional**  
***Fashionable / Useful***



Los acabados de la luminaria PATIO, así como su diseño sereno y nada estridente, le confieren una gran elegancia aparte de su funcionalidad, al poderse colocar en cualquier sitio independientemente de tener una toma de corriente cercana. El difusor está fabricado en polietileno rotomoldeado en color natural y el cuerpo es de aluminio arenado y anodizado, disponible en dos versiones: plata y oro.

***The finishes of the PATIO lamp, as well as its serene and smart design, give it great elegance apart from its functionality, as it can be placed anywhere regardless of having a plug nearby. The diffuser molded polyethylene in natural color and the body is made of sandblasted and anodized aluminium, available in two versions: silver and gold.***

Se puede suministrar:

- Sin cable cargador (se puede usar el de un teléfono móvil).
- Con 1 cargador y 1 cable USB para 1 luminaria.
- Con 1 cargador múltiple con 6 cables USB para cargar simultáneamente 6 luminarias.

***It can be ordered:***

- ***Without charger (the charger from a mobile phone can be used).***
- ***With 1 charger and 1 USB cable for 1 lamp***
- ***With 1 multiple charger and 6 USB cables to simultaneously charge 6 lamps.***







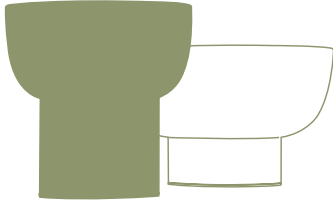

## Usb / Inalámbrico *Usb / Wireless*



PATIO es una luminaria sin cables pensada para iluminar una mesa, ya sea en interior como en exterior, sin necesidad de disponer de una toma de corriente. Una aplicación ideal para hostelería y hotelería.

Utiliza una fuente de luz LED de 3W con un rendimiento máximo de 260 lúmenes. Gracias a su pantalla en polietileno rotomoldeado, esta luz se disipa homogéneamente iluminando el espacio sin sombras y la cubierta de aluminio anodizado evita el deslumbramiento de los comensales. Dispone de una batería de li-ion que permite una autonomía de máxima de 17 horas que se carga mediante un conector Micro USB (igual que el de un teléfono móvil) situado en la base. También dispone de un pulsador de encendido y apagado con tres posiciones de encendido, para ajustar la luz según la necesidad de cada momento. La base dispone de unos topes de silicona para evitar que la luminaria se deslice, en caso que la superficie de apoyo no sea estable, como en caso de barcos o autocaravanas.



*PATIO is a wireless lamp ideal for installations, designed to illuminate a table, either indoors or outdoors, without the need of a plug. Perfect for its use in hotels, restaurants, terraces...*

*It uses a 3W LED light source with a maximum output of 260 lumens. Thanks to its polyethylene rotomolded shade, the light is dissipated evenly illuminating the space without shadows and the aluminium cover prevents the glare to the people sitting around the table. It houses a li-ion battery that allows 17 hours of authonomy, that is charged with a USB charger (like the ones used for mobile phones) located at the base. Besides it has an on-off switch with three positions to adjust the light according to the needs of each moment. The base has silicone stoppers to prevent the luminaire to slide, in case the surface is not stable, as in boats or mobile homes.*





2010/010  
2010/016

2000/010  
2000/016

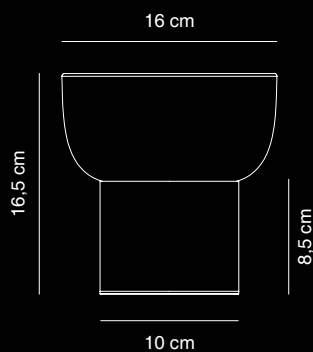
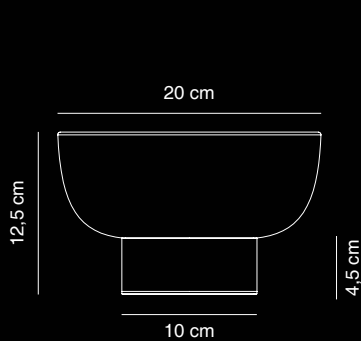

## Patio

Design by Oriol LLahona

Estructura aluminio anodizado  
**Structure anodized aluminium**

Pantalla polietileno rotomoldeado  
**Shade molded polyethylene**

Luminaria con batería Li-ion. Autonomía intensidad baja 17h, intensidad media 7h, intensidad alta 4h. Carga completa 8h. Cargador USB no incluido (ver referencias abajo). Lámpara incluida, no reemplazable. ON/OFF dimmer 3 posiciones.

**Li-ion battery lamp. low intensity 17h, medium intensity 7h, high intensity 4h Total charge 8h. USB charger not included (See codes below). Lamp included, not replaceable. ON/OFF 3 steps Dimmer**

2000/010 16,50cm dorado **gold**

2000/016 16,50cm plata **silver**

2010/010 12,50cm dorado **gold**

2010/016 12,50cm plata **silver**

LED 5V 1.2A - max.3W 260lm

9995/010 Cargador USB simple 5V 1.5A + 1,5mt cable  
**Single 5V 1.5A charger + 1.5m USB cable**

9996/060 Cargador múltiple 6 x USB 5V 1.5A + 1,5mt cable  
**Multiple charger 6 x 5V 1.5A + 1.5m cable**









## Bell

Design by Cristian Cubiñá

Estructura madera maciza de Iroco  
**Structure massive Iroco wood**

Pantalla de latón pulido barnizado mate  
**Shade polished brass matt varnished**

Luminaria con batería de polímero de Litio. Autonomía 7h, carga completa 5h. Cargador USB no incluido (ver referencias abajo).

Lámpara incluida, no reemplazable. ON/OFF/Touch dimmer  
**Lithium polymer battery 7h autonomy. Complete charge 5h. USB charger not included (See codes below). Lamp included, not replaceable. ON/OFF/Touch Dimmer**

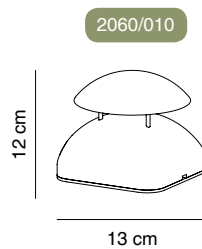
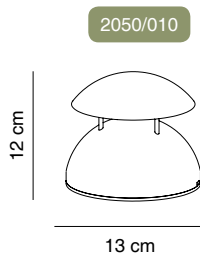

2050/010 redondo **round**

2060/010 cuadrado **square**

LED 1,3W 3000K 150lm

9995/010 Cargador USB simple 5V 1.5A + 1,5mt cable  
**Single 5V 1.5A charger + 1.5m USB cable**

9996/060 Cargador múltiple 6 x USB 5V 1.5A + 1,5mt cable  
**Multiple charger 6 x 5V 1.5A + 1.5m cable**

CE   

















## Cuadrat

Design by Josep Novell & Ernest Perera

Estructura de hierro pintado texturado  
**Structure texturized epoxy painted iron**

Pantalla polietileno rotomoldeado  
**Shade texturized rotomoulded polyethylene**

Luminaria con batería de polímero de Litio. Autonomía 7h, carga completa 5h. Cargador USB no incluido (ver referencias abajo).

Lámpara incluida, no reemplazable. ON/OFF/Touch dimmer  
**Lithium polymer battery 7h autonomy. Complete charge 5h. USB charger not included (See codes below). Lamp included, not replaceable. ON/OFF/Touch Dimmer**

2160/011 blanco **white**

2160/012 corten **corten**

2160/018 antracita **anthracite**

LED 1,3W 3000K 150lm



9995/010 Cargador USB simple 5V 1.5A + 1,5mt cable

**Single 5V 1.5A charger + 1.5m USB cable**

9996/060 Cargador múltiple 6 x USB 5V 1.5A + 1,5mt cable

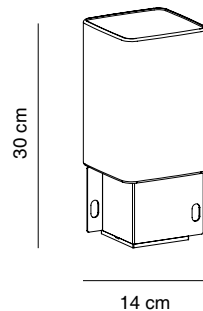
**Multiple charger 6 x 5V 1.5A + 1.5m cable**



CE   





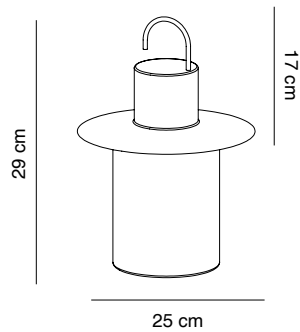

## Nautic

Design by Josep Novell & Ernest Perera

Estructura de aluminio pintado texturado  
**Structure texturized epoxy painted aluminium**

Pantalla polietileno rotomoldeado  
**Shade texturized rotomoulded polyethylene**

Luminaria con batería de polímero de Litio. Autonomía 7h, carga completa 5h. Cargador USB no incluido (ver referencias abajo).

Lámpara incluida, no reemplazable. ON/OFF/Touch dimmer  
**Lithium polymer battery 7h autonomy. Complete charge 5h. USB charger not included (See codes below). Lamp included, not replaceable. ON/OFF/Touch Dimmer**

5210/011 blanco **white**



5210/012 corten **corten**

5210/018 antracita **anthracite**

LED 1,3W 3000K 150lm

9995/010 Cargador USB simple 5V 1.5A + 1,5mt cable  
**Single 5V 1.5A charger + 1.5m USB cable**

9996/060 Cargador múltiple 6 x USB 5V 1.5A + 1,5mt cable  
**Multiple charger 6 x 5V 1.5A + 1.5m cable**

CE  IP 45 





# Sobremesas Table Lamps

Aspen / Blow / Candle / Capsule / CapsuleHat / Deco / Fuji / Hotel / Note  
/ Paros Alabaster / Star / Tribeca



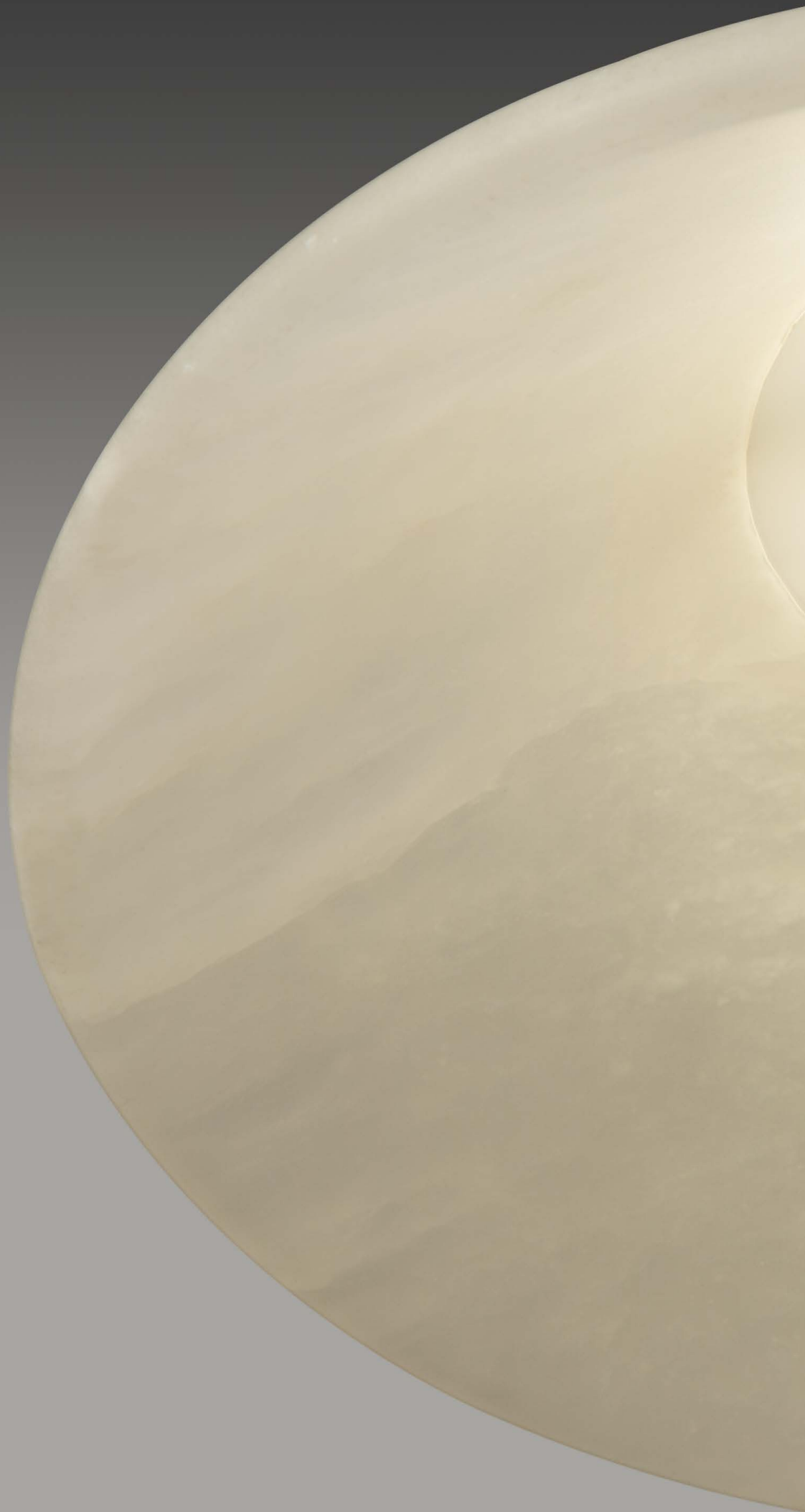



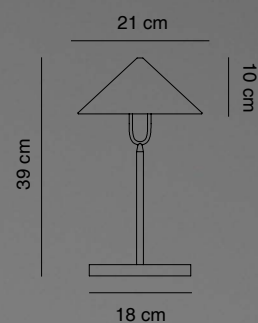

## Fuji

Design by Jordi LLopis

Pantalla alabastro  
**Shade alabster**



Estructura hierro baño electrolítico latón pulido  
brillo  
**Structure iron with electrolytic bath in polished brass finish**

Sin regulador. Versión dimable bajo pedido  
**Without dimmer. Dimmable version upon request**

Lámpara incluida y no reemplazable  
**Lamp included and not replaceable**

2070/010

LED Seoul 4,6W 2700K 260lm

CE   











## Tribeca

Design by Jordi LLopis

---

Pantalla alabastro  
**Shade alabaster**

Estructura hierro pintado negro texturado  
**Structure black texturized epoxy painted iron**

Lámpara Led incluida, no reemplazable  
**Led lamp included, not replaceable**

---

No regulable **Not dimmable**  
2800/018 negro **black**



---

Regulable. Driver enchufable  
**Dimmable. Plug in driver**

2800/018RG negro **black**

LED Seoul 4.5W 2700K 270lm

---

CE   

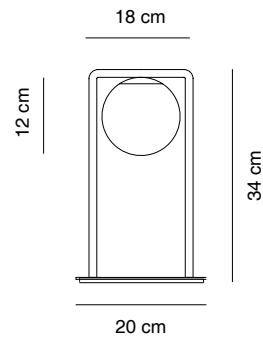



La otra mujer



Andrés Martín

Roberto Aringoni Nuestros años verde olivo

El segundo círculo

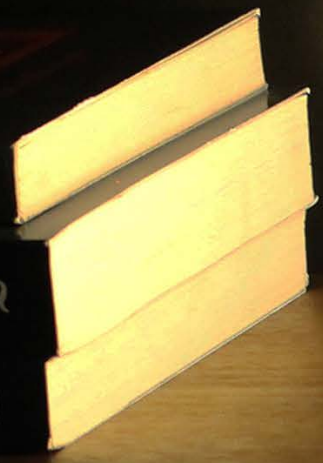





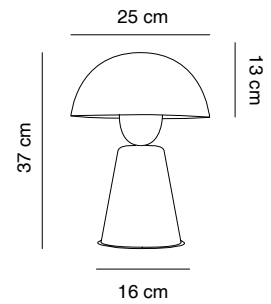

## Star

Design by Cristian Cubiña

Pantalla metacrilato opal  
**Shade opal methacrylate**

Estructura hierro pintado brillante  
**Structure gloss iron painted**



Con regulador  
**With dimmer**

Lámpara no incluida  
**Lamp not included**

2085/011 blanco **white**

2085/018 negro **black**

 E27 LED

CE   









## Paros Alabaster

Design by Josep Novell & Ernest Perera

Pantalla alabastro  
**Shade alabaster**

Estructura hierro pintado blanco texturado  
**Structure texturized white painted iron**

Sin regulador **without dimmer**



Lámpara no incluida  
**Lamp not included**

2270/011 blanco **white**

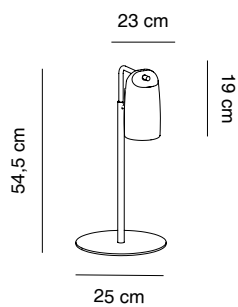

E14 / LED



CE   IP 20  A<sup>+</sup>



Barcelona, ciudad novela

ES  
SANTALUCEA





## CapsuleHat

Design by Cristian Cubiñá

Pantalla cristal opal / hierro  
**Shade opal glass / iron**

Estructura hierro pintado texturado  
**Structure texturized epoxy painted iron**

Sin regulador **without dimmer**

Lámpara no incluida  
**Lamp not included**



2520/011 blanco **white**

2520/012 corten **corten**

2520/018 antracita **anthracite**

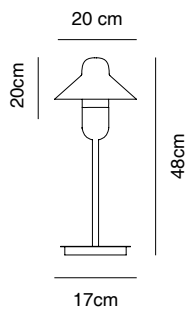
 G9 LED



CE   



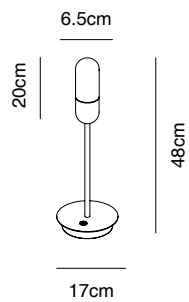

## Capsule

Design by Cristian Cubiñá

Pantalla cristal opal  
**Shade opal glass**

Estructura hierro pintado texturado  
**Structure texturized epoxy painted iron**

Sin regulador **without dimmer**

Lámpara no incluida  
**Lamp not included**

2320/011 blanco **white**

2320/012 corten **corten**

2320/018 antracita **anthracite**

 G9 LED

CE  IP 20 







## Deco

Design by Cristian Cubiñá

Estructura hierro cromado  
**Structure chromed iron**

Pantalla cristal prensado de Bohemia en acabado transparente o degradado ámbar o turquesa  
**Shade Pressed Bohemia crystal in transparent finish, or gradated amber or turquoise**

Sin regulador **Without dimmer**

Lámpara no incluida  
**Lamp not included**

2550/011 Cromo - Transparente **Chrome - Transparent**

2550/012 Cromo - Ambar **Chrome - Amber**



2550/015 Cromo - Turquesa **Chrome - Turquoise**

2530/011 Dorado - Transparente **Gold - Transparent**

2530/012 Dorado - Ambar **Gold - Amber**

2530/015 Dorado - Turquesa **Gold - Turquoise**

 E14 LED

CE   IP 20  A+

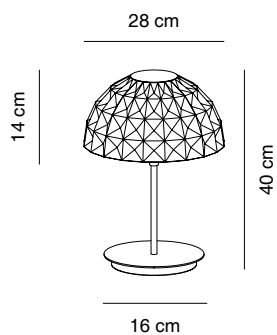





## Candle

Design by Cristian Cubiñá

Cristal soplado triplex opal  
**Opal triplex blown glass**

Con regulador *with dimmer*

Lámpara incluida no reemplazable  
**Lamp included, not replaceable**

2250/011 Blanco **White**

2250/016 Niquel **Matt nickel**

2250/017 Cromo **Chrome**

LED 6W 3000K

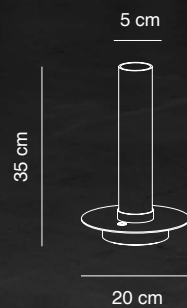

CE   



## Hotel

Design by Cristian Cubiñá

Estructura hierro acabado níquel mate  
**Structure matt nickel iron**



Pantalla algodón negro  
**Shade black cotton**

Sin regulador **Without dimmer**

Lámpara no incluida  
**Lamp not included**

2540/018 níquel/negro **nickel/black**

 E27 LED

CE  IP20 

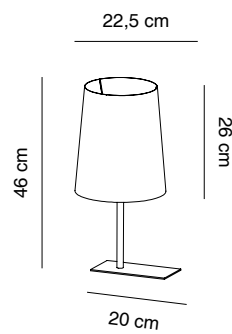











# Blow

Design by Josep Novell & Ernest Perera

Estructura hierro/latón  
**Structure iron/ brass**

Pantalla cristal soplado  
**Blown glass shade**

Lámpara incluida y no reemplazable. No regulable  
**Lamp included and not replaceable. Not dimmable**

2700/011 blanco sin cristal **white without glass**

2700/016 níquel mate sin cristal **matt nickel, without glass**

2700/017 cromo sin cristal **chrome without glass**

LED Cree 3W 3000K 180lm

Cristales para combinar  
**Glasses to combine**

0000/A00 cristal A **A glass**

0000/B00 cristal B **B glass**

0000/C00 cristal C **C glass**

0000/D00 cristal D **D glass**

0000/E00 cristal E **E glass**

0000/F00 cristal F **F glass**

0000/G00 cristal G **G glass**

0000/H00 cristal H **H glass**

CE  IP 20  A\*

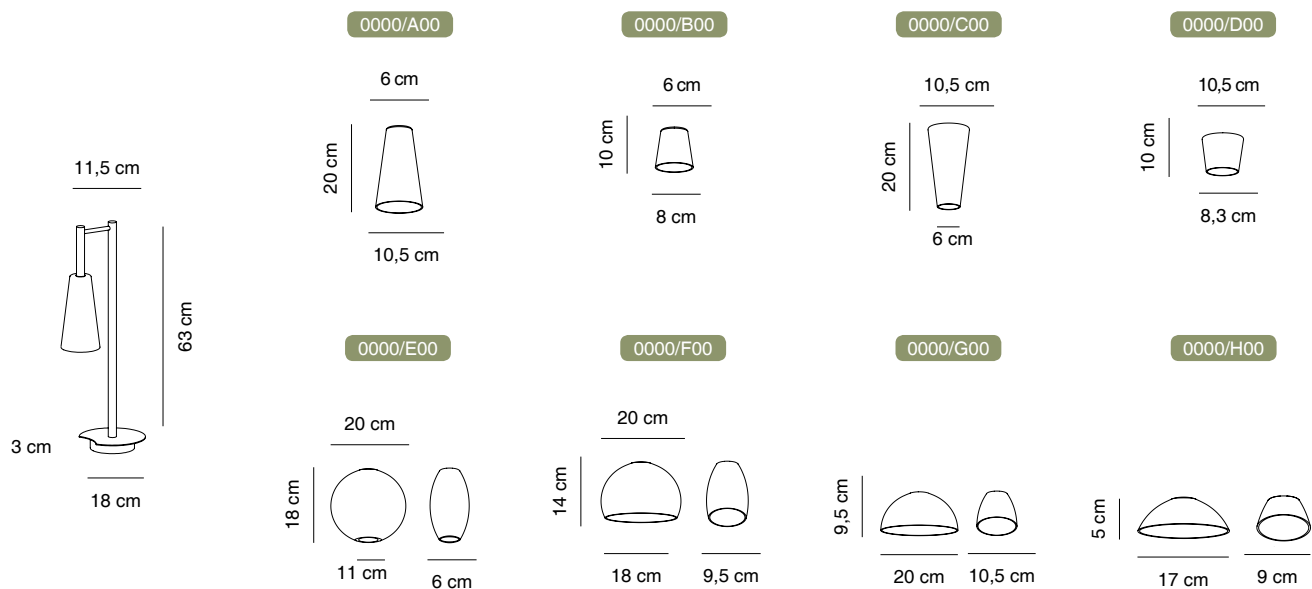



## Note

Design by Oriol Llahona

---

Estructura aluminio anodizado o pintado epoxi texturizado  
**Structure anodized or textured epoxy painted aluminium**

Pantalla cristal óptico arenado  
**Shade sandblasted optic glass**

Con regulador/Lámpara no incluida  
**With dimmer/Lamp not included**

---

2900/011 blanco **white**



2900/015 rojo **red (ral 3020)**

2900/016 anodizado plata **silver anodized**

2900/018 negro **black**

 G9 LED

---

CE   

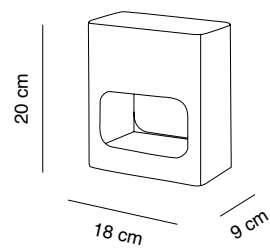





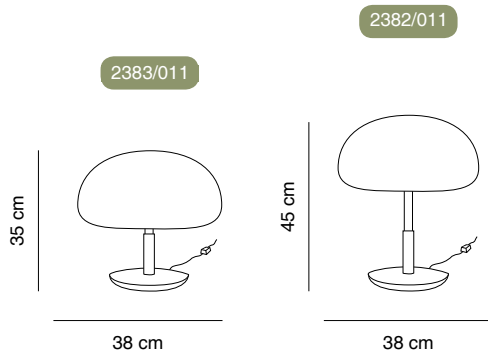

## Aspen

Design by Javier Taberner & Nacho Poveda

Pantalla cerámica esmaltada brillante  
**Shade shiny enamelled ceramic**

Estructura madera de roble / hierro pintado epoxi  
/cable textil

**Structure oak wood / epoxi painted iron /  
textile cable**

Sin regulador **Without dimmer**

Lámpara no incluida  
**Lamp not included**

2382/011 blanco **white**

2383/011 blanco **white**

3xE14 LED

CE  IP 20 **A**

# Lámparas de pie

# Floor Lamps

Big Brother / Blow / Capsule / CapsuleHat / Deco / Fuji / Hotel / Led Pole /  
Note / Paros Alabaster / Star / Tribeca / Work













## Fuji

Design by Jordi Llopis

Pantalla alabastro  
**Shade alabster**



Estructura hierro baño electrolitico laton pulido brillo  
**Structure iron with electrolytic bath in polished brass finish**

Sin regulador. Versión dimable bajo pedido  
**Without dimmer. Dimmable version upon request**

Lámpara incluida y no reemplazable  
**Lamp included and not replaceable**

3070/010

LED 230V 4,83W 2700K 335lm

CE  IP 20 





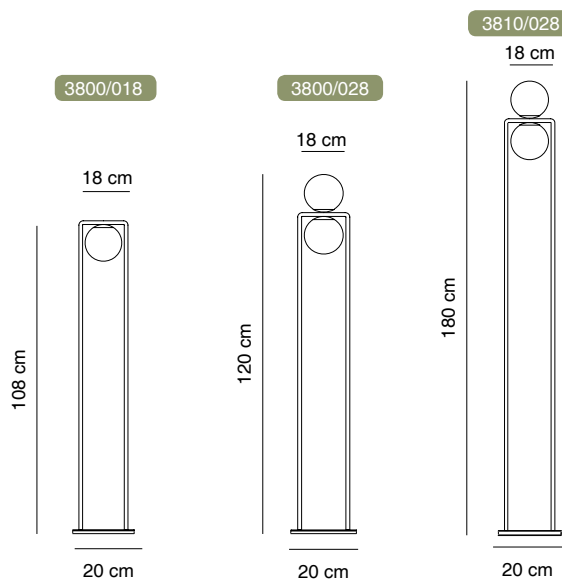
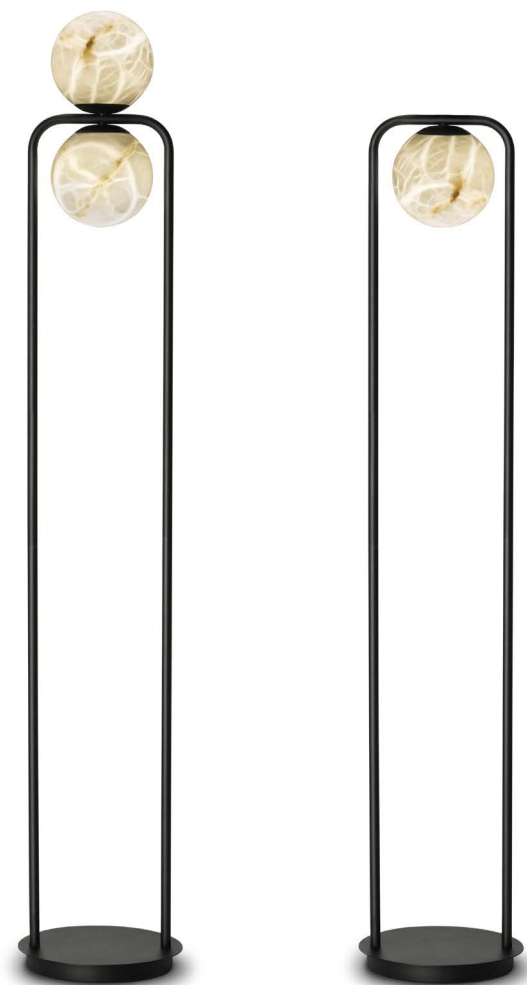

## Tribeca

Design by Jordi LLopis

Pantalla alabastro  
**Shade alabaster**

Estructura hierro pintado negro texturado  
**Structure black textured epoxy painted iron**

Lámpara Led incluida, no reemplazable  
**Led lamp included, not replaceable**

No regulable **Not dimmable**  
3800/018 108cm negro **black**  
3800/028 120cm negro **black**  
3810/028 180cm negro **black**

Regulable. Driver enchufable  
**Dimmable. Plug in driver**

3800/018RG 108cm negro **black**  
3800/028RG 120cm negro **black**  
3810/028RG 180cm negro **black**

LED Seoul 4.5W 2700K 270lm

CE  IP 20  A+







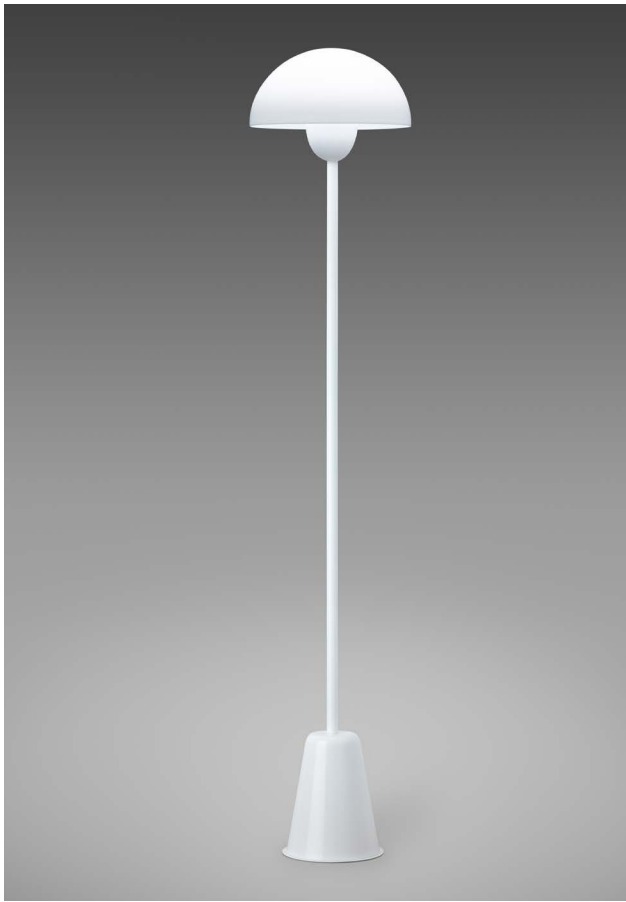

# Star

Design by Cristian Cubiña

Pantalla metacrilato opal  
**Shade opal methacrylate**

Estructura hierro pintado brillante  
**Structure gloss iron painted**

**Con regulador**  
**With dimmer**

Lámpara no incluida  
**Lamp not included**

3085/011 blanco **white**  
3085/018 negro **black**

 E27 LED

CE  IP 20  A+

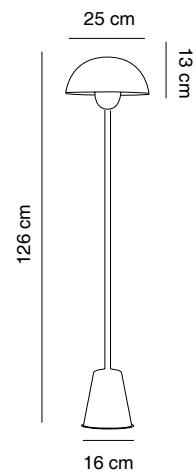





## Paros Alabaster

Design by Josep Novell & Ernest Perera

Pantalla alabastro  
**Shade alabaster**



Estructura hierro pintado blanco texturado  
**Structure texturized white painted iron**

Sin regulador **without dimmer**

Lámpara no incluida, reemplazable  
**Lamp not included, replaceable**

3270/011 blanco **white**

 E14 LED

CE   

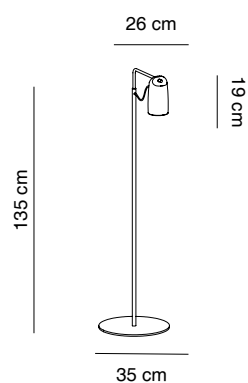

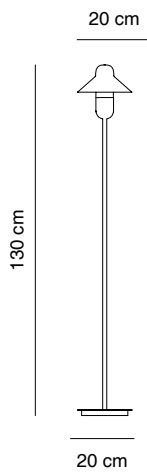

## CapsuleHat

Design by Cristian Cubiñá

---

Pantalla cristal opal / hierro  
**Shade opal glass / iron**

Estructura hierro pintado texturado  
**Structure texturized epoxy painted iron**

Sin regulador **without dimmer**

Lámpara no incluida  
**Lamp not included**

---

3520/011 blanco **white**

3520/012 corten **corten**

3520/018 antracita **anthracite**

 G9 LED

---

CE   



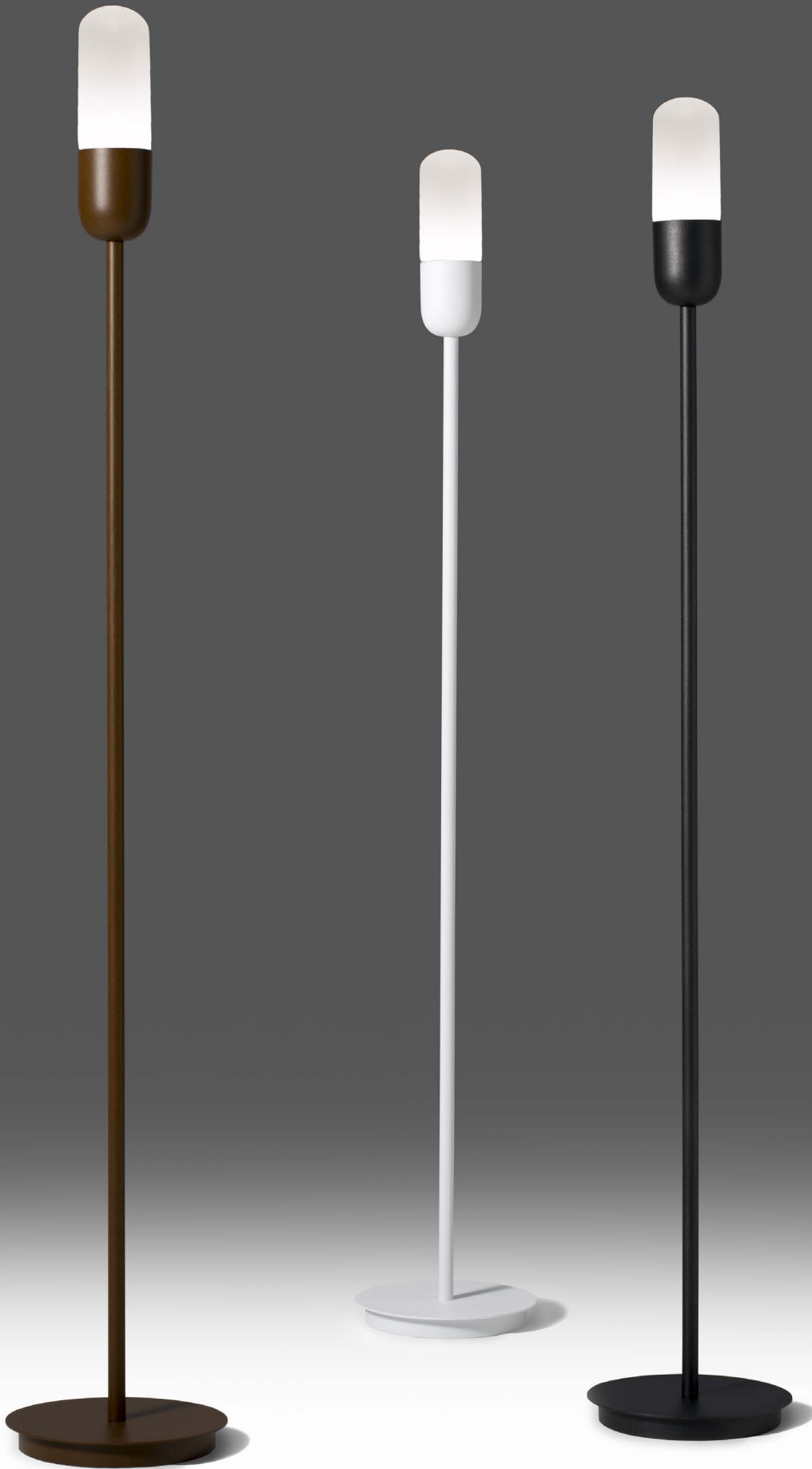

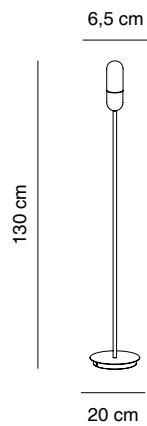

## Capsule

Design by Cristian Cubiñá

Pantalla cristal opal  
**Shade opal glass**

Estructura hierro pintado texturado  
**Structure texturized epoxy painted iron**

Sin regulador **without dimmer**

Lámpara no incluida  
**Lamp not included**

3320/011 blanco **white**

3320/012 corten **corten**

3320/018 antracita **anthracite**

 G9 LED

CE   





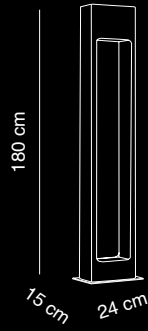

## Note

Design by Oriol Llahona

Estructura aluminio anodizado o pintado epoxi texturizado  
**Structure anodized or texturized epoxy painted aluminium**

Pantalla cristal óptico arenado  
**Shade sandblasted optic glass**

Con regulador / Lámpara no incluida  
**With dimmer / Lamp not included**

3900/011 blanco **white**

3900/015 rojo **red (Ral 3020)**

3900/016 anodizado plata **silver anodized**

3900/018 negro **black**

 R7s 115mm, min. 4W - max. 200W ECO / LED

CE   

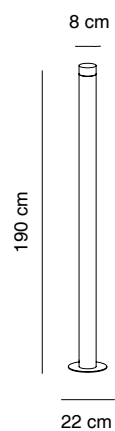

## Led Pole

Design by Cristian Cubiñá

---

Estructura extrusión aluminio  
**Structure extruded aluminum**

Pantalla metacrilato arenado  
**Shade sand blasted methacrylate**

Lámpara incluida y no reemplazable. Con regulador  
**Lamp included and not replaceable. With dimmer**

---

3160/011 blanco texturado **textured white**

3160/018 negro texturado **textured black**

3160/016 anodizado plata **anodized silver**

3160/010 anodizado oro **anodized gold**

LED Talex Stark module 20W 3500lm 3000K

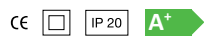

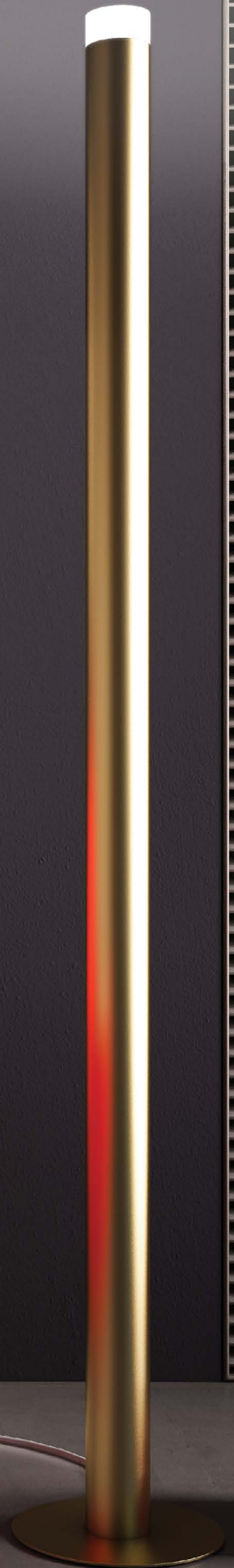







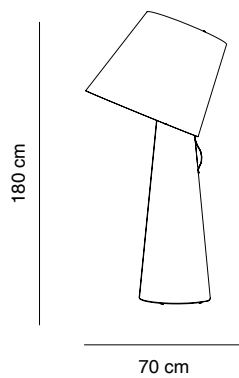

## Big Brother

Design by Oriol Llahona

Estructura hierro pintado epoxi blanco  
**Structure iron powder coated**



Pantalla textil blanco y asa en cuero grabado  
**Shade white textile and engraved leather handle**

Con regulador **With dimmer**

Lámpara no incluida  
**Lamp not included**

3950/011 blanco **white**

 3 X E27 LED

CE  IP 20 

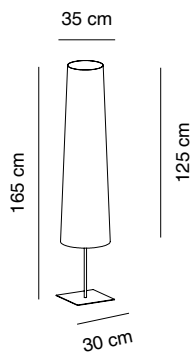

## Hotel

Design by Cristian Cubiñá

Estructura hierro acabado níquel mate  
**Structure matt nickel iron**

Pantalla algodón negro  
**Shade black cotton**

Sin regulador **without dimmer**

Lámpara no incluida  
**Lamp not included**

3540/018 níquel/negro **nickel/black**

 E27 LED

CE  IP 20 







## Deco

Design by Cristian Cubiñá

Estructura hierro cromado

**Structure chromed iron**

Pantalla cristal prensado de Bohemia en acabado transparente o degradado ámbar o turquesa

**Shade Pressed Bohemia crystal transparent glass or gradated amber or turquoise**

Sin regulador **Without dimmer**

Lámpara no incluida

**Lamp not included**

3550/011 Cromo -Transparente **Chome - Transparent**

3550/012 Cromo - Ambar **Chome - Amber**

3550/015 Como - Turquesa **Chome - Turquoise**

3530/011 Dorado -Transparente **Gold - Transparent**

3530/012 Dorado - Ambar **Gold - Amber**

3530/015 Dorado - Turquesa **Gold - Turquoise**



E14 LED



IP 20



A+

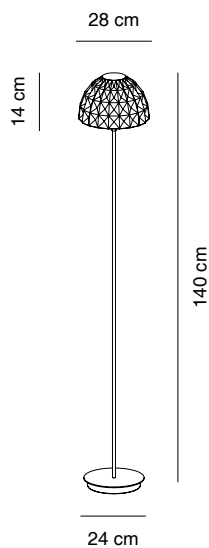



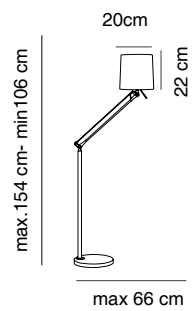

## Work

Estructura aluminio anodizado plata  
**Structure aluminium silver anodized**



Pantalla textil almadén plata  
**Shade silver almaden textile**

Sin regulador **Without dimmer**

Lámpara no incluida  
**Lamp not included**

4245/019 plata **silver**

 E27 LED

CE   



# Suspensiones Hanging Lamps

Bath A Led / Biscuit / Blow / Capsule / CapsuleHat / Deco / Double / Drop  
Led / Fuji / Led Box / Led Oval / Lens Led / Moon / Paros Alabaster / Soft  
/ Spike / Stone Led / Sun Led / SuperMoon / TheChandelier / TheLight /  
ThePalm / Tribeca



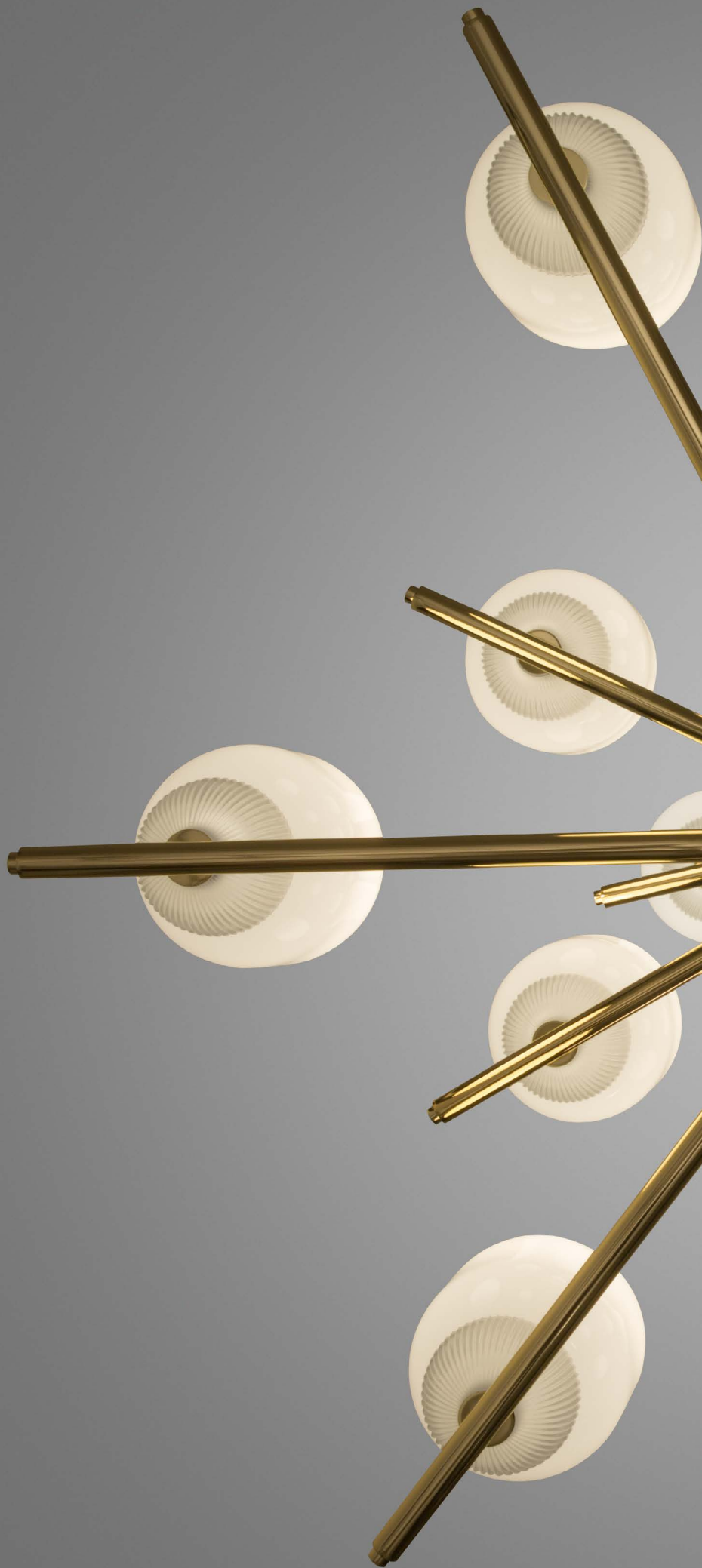

























# TheChandelier

Design by Alfonso de la Fuente (Pichiglas Studio)

Estructura hierro  
**Structure iron**

Pantalla cristal opal  
**Shade opal glass**

Lámparas no incluidas **Lamps not included**

5170/031 colgante 3 brazos blanco texturado **pendant 3 arms white**

5170/038 colgante 3 brazos negro texturado **pendant 3 arms black**

5170/030 colgante 3 brazos latón brillo **pendant 3 arms polished brass finishing**

5170/091 colgante 9 brazos blanco texturado **pendant 9 arms white**

5170/098 colgante 9 brazos negro texturado **pendant 9 arms black**



5170/090 colgante 9 brazos latón brillo **pendant 9 arms polished brass finishing**

5170/151 colgante 15 brazos blanco texturado **pendant 15 arms white**

5170/158 colgante 15 brazos negro texturado **pendant 15 arms black**

5170/150 colgante 15 brazos latón brillo **pendant 15 arms polished brass finishing**

 E27 LED

CE  IP 20 

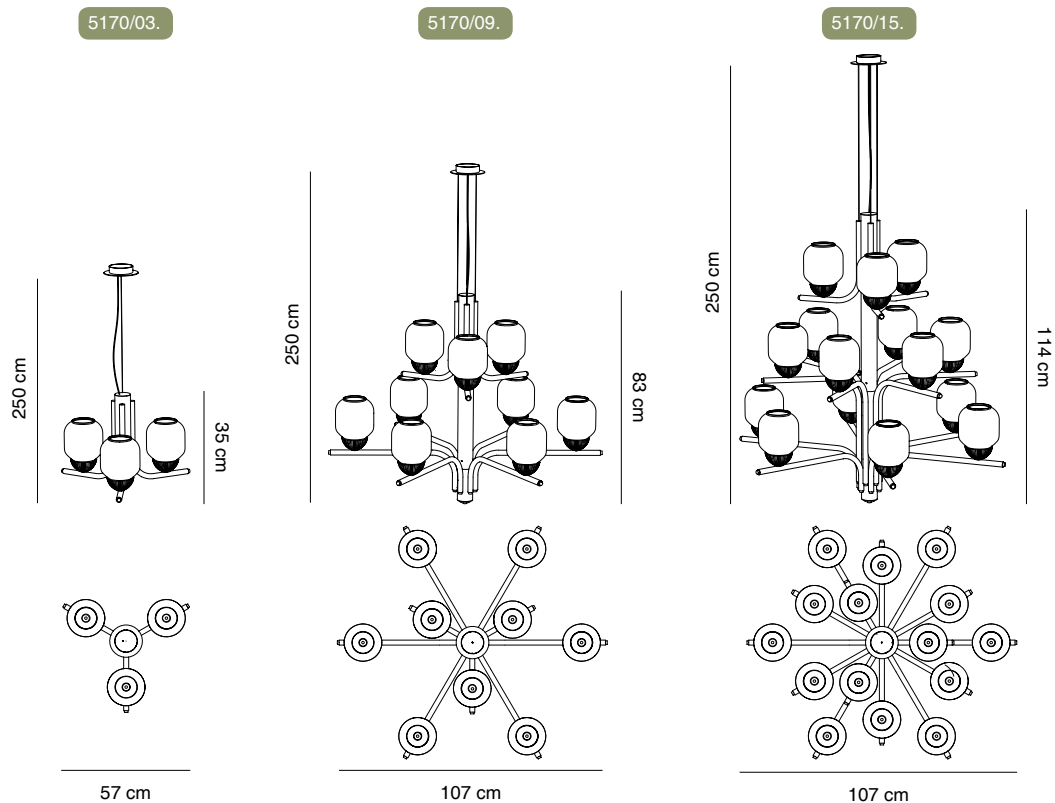









## Fuji

Design by Jordi Llopis

Pantalla alabastro  
**Shade alabster**

Estructura hierro baño electrolítico latón pulido brillo  
**Structure iron with electrolytic bath in polished brass finish**

No regulable. Versión dimable bajo pedido  
**Not dimmable. Dimmable version upon request**

Lámpara incluida y no reemplazable  
**Lamp included and not replaceable**



5070/010 Pantalla pequeña **small shade**

LED Seoul 4,6W 2700K 260lm

5071/010 Pantalla grande **big shade**

LED 230V 4,85W 2700K 335lm

CE  IP 20 **A+**









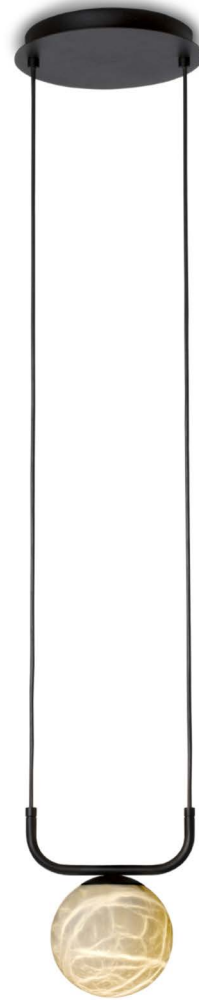
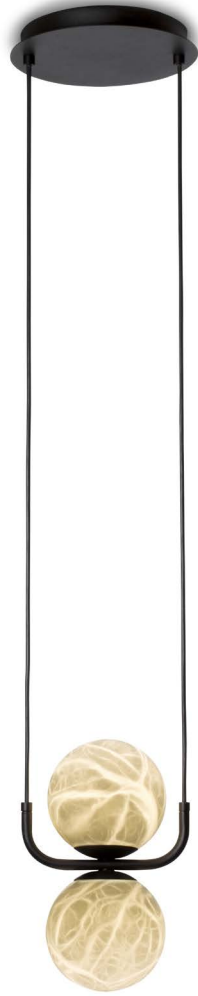

5800/018

5800/028

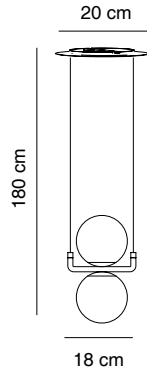
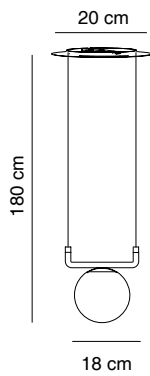

## Tribeca

Design by Jordi LLopis

Pantalla alabastro  
**Shade alabaster**

Estructura hierro pintado negro texturado  
**Structure black texturized epoxy painted iron**

Regulable mediante Triac. Lámpara incluida y no reemplazable  
**Dimming through Triac . Lamp included and not replaceable**

5800/018 negro **black**  
5800/028 negro **black**

LED Seoul 4.5W 2700K 270lm

CE   



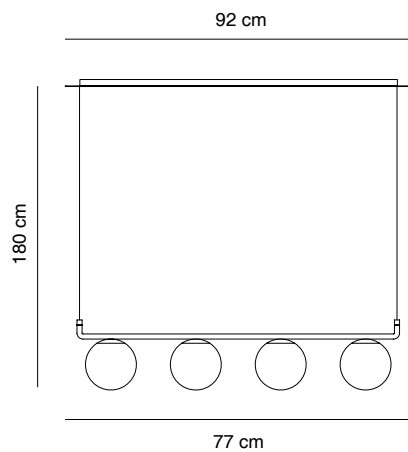
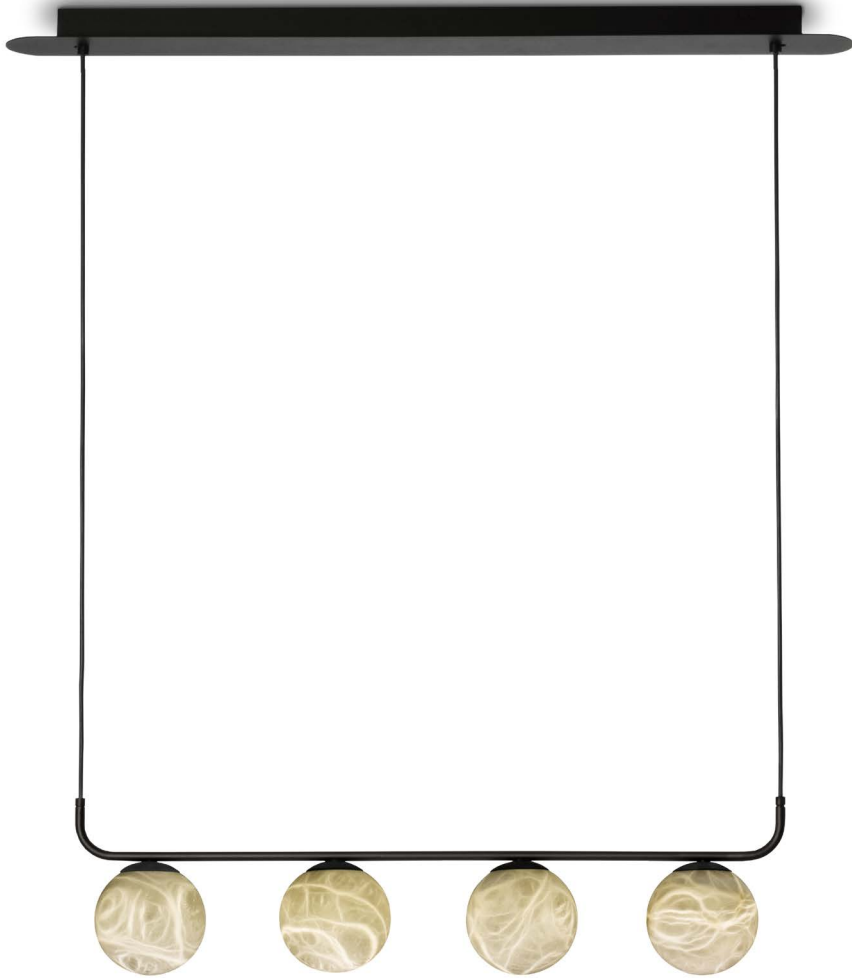

## Tribeca

Design by Jordi LLopis

Pantalla alabastro  
**Shade alabaster**

Estructura hierro pintado negro texturado  
**Structure black texturized epoxy painted iron**

Regulable mediante Triac. Lámpara incluida y no reemplazable  
**Dimming through Triac . Lamp included and not replaceable**

5800/048 negro **black**

4 x LED Seoul 4,5W 2700K 270lm

CE  IP 20 **A+**



## Paros Alabaster

Design by Josep Novell & Ernest Perera



Pantalla alabastro  
**Shade alabaster**

Estructura hierro pintado blanco texturado  
**Structure texturized white painted iron**

Lámpara no incluida  
**Lamp not included**

5270/011 blanco **white**

 E14 LED

CE   

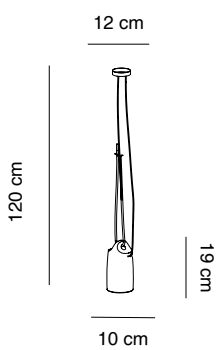













## ThePalm

Design by Cristian Cubiñá

---

Estructura hierro  
**Structure iron**

Pantalla metacrilato arenado  
**Shade sandblasted methacrylate**

Lámparas incluidas y no reemplazables  
**Lamps included and not replaceable**

---

5190/121 colgante 12 brazos blanco texturado **pendant 12 arms white**

5190/126 colgante 12 brazos níquel satinado **pendant 12 arms satin nickel**

5190/120 colgante 12 brazos dorado satinado **pendant 12 arms satin gold**

5190/181 colgante 18 brazos blanco texturado **pendant 18 arms white**

5190/186 colgante 18 brazos níquel satinado **pendant 18 arms satin nickel**

5190/180 colgante 18 brazos dorado satinado **pendant 18 arms satin gold**

5190/301 colgante 30 brazos blanco texturado **pendant 30 arms white**

5190/306 colgante 30 brazos níquel satinado **pendant 30 arms satin nickel**

5190/300 colgante 30 brazos dorado satinado **pendant 30 arms satin gold**

LED Cree 1,9W 2700K 158lm

---

CE IP 20 A+

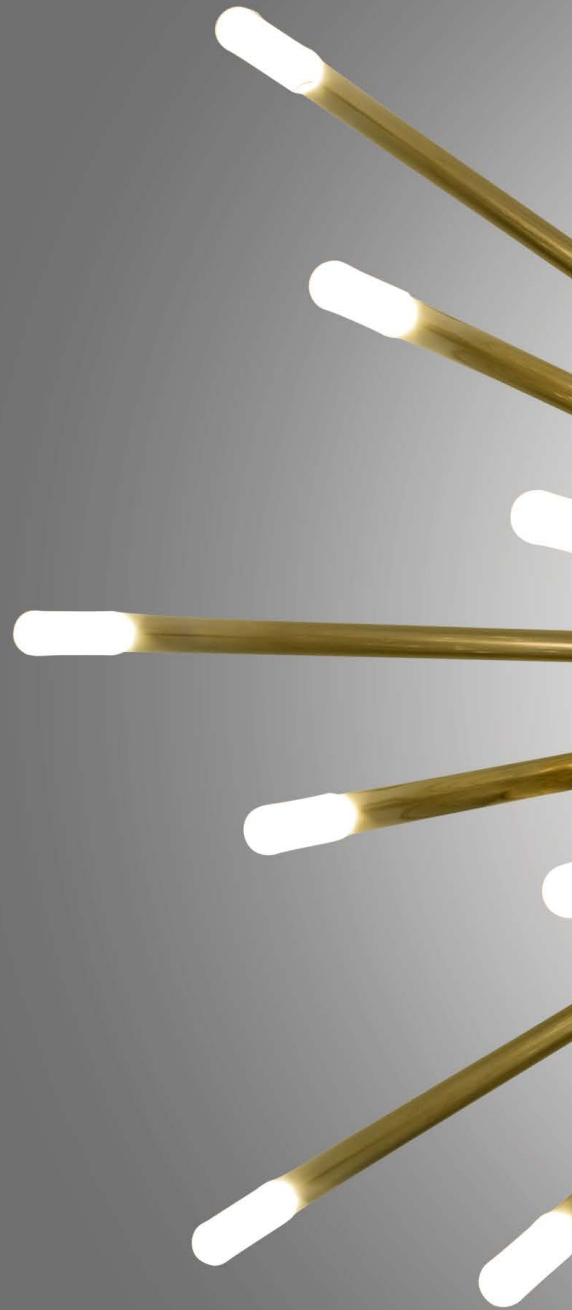
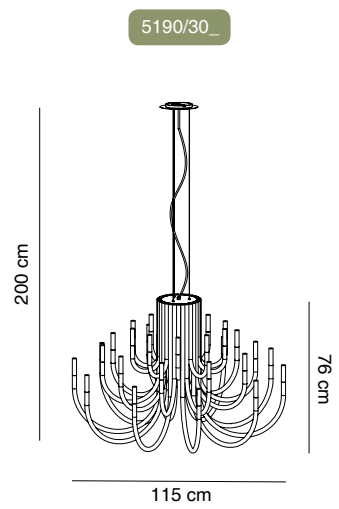
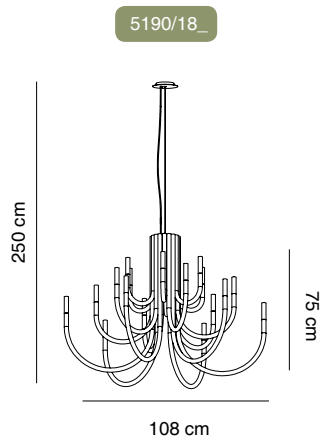
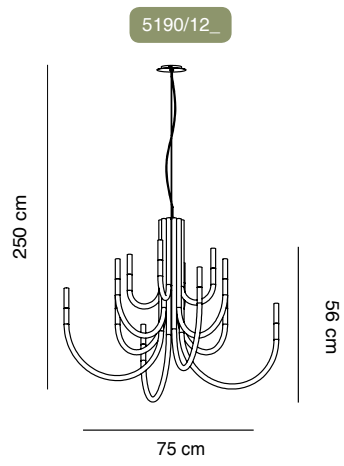

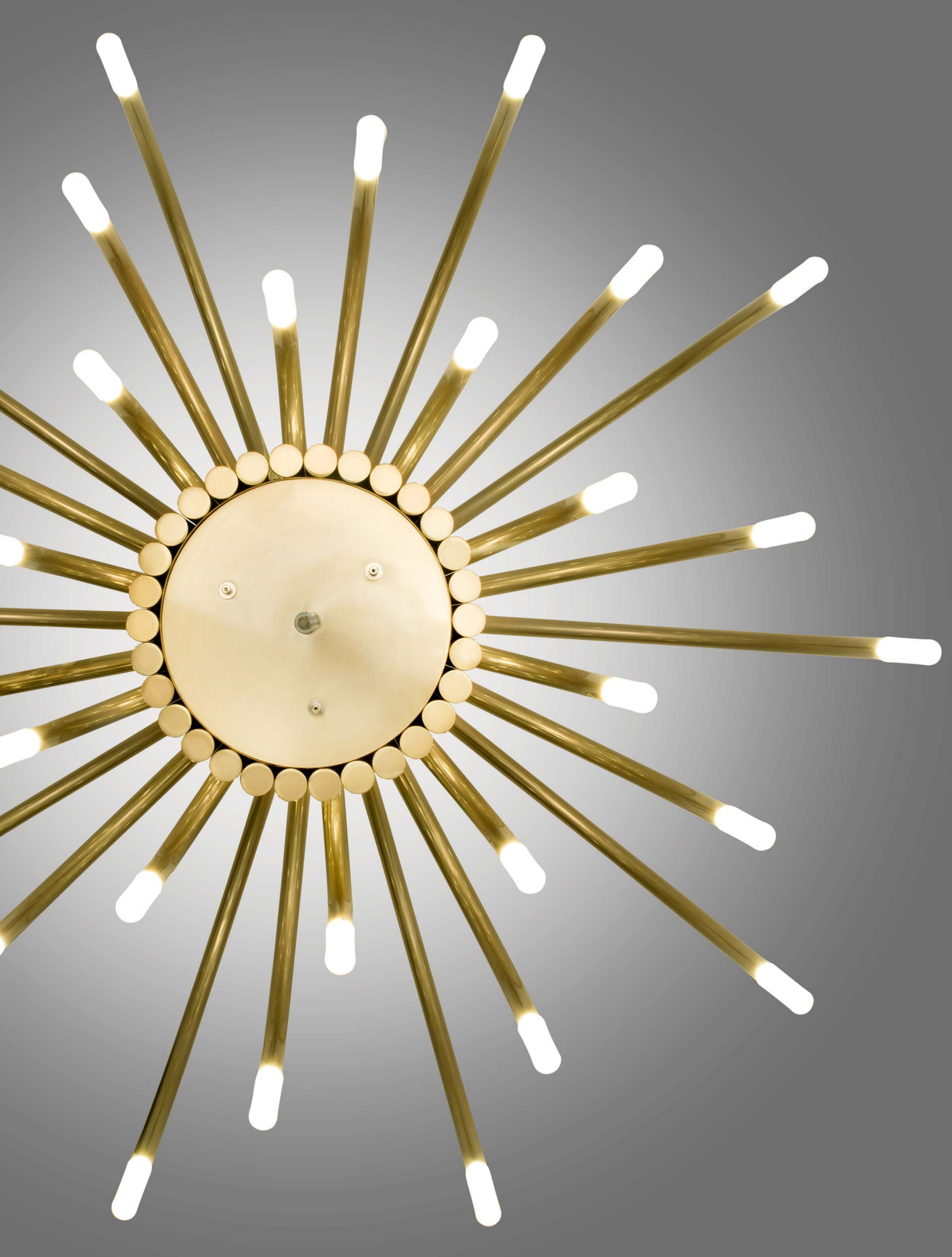









5150/30...

250 cm

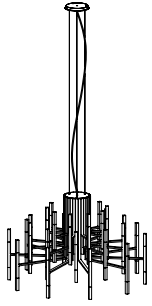

70 cm

109 cm

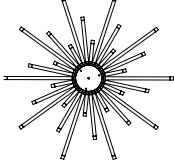

109 cm

5150/18...

250 cm

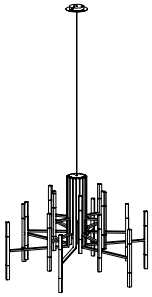

70 cm

102 cm

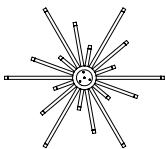

102 cm

5150/12...

250 cm

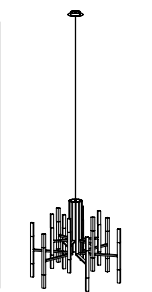

60 cm

67,5 cm

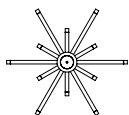

67,5 cm





# TheLight

Design by Cristian Cubiñá

---

Estructura hierro  
**Structure iron**

Pantalla metacrilato arenado  
**Shade sandblasted methacrylate**

Lámparas incluidas y no reemplazables  
**Lamps included and not replaceable**

---

5150/121 colgante 12 brazos blanco **pendant 12 arms white**

5150/126 colgante 12 brazos níquel satinado **pendant 12 arms satin nickel**

5150/120 colgante 12 brazos dorado satinado **pendant 12 arms satin gold**

5150/181 colgante 18 brazos blanco **pendant 18 arms white**

5150/186 colgante 18 brazos níquel satinado **pendant 18 arms satin nickel**

5150/180 colgante 18 brazos dorado satinado **pendant 18 arms satin gold**

5150/301 colgante 30 brazos blanco **pendant 30 arms white**

5150/306 colgante 30 brazos níquel satinado **pendant 30 arms satin nickel**

5150/300 colgante 30 brazos dorado satinado **pendant 30 arms satin gold**

LED Cree 1,9W 2700K 105lm

---

CE IP 20 A+

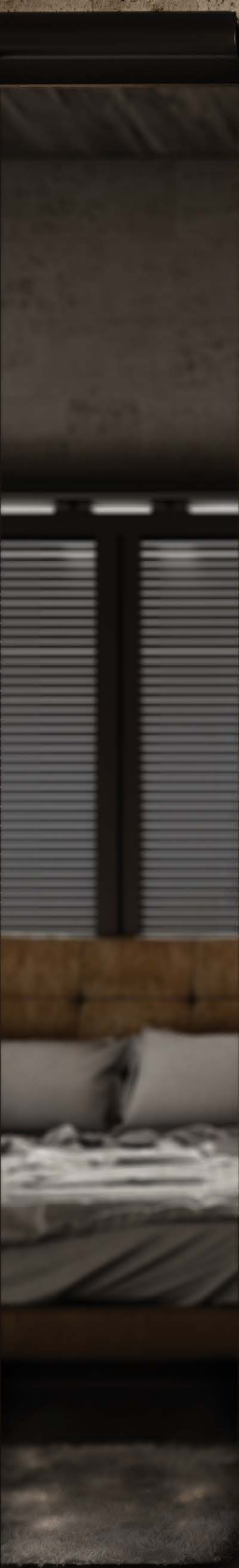

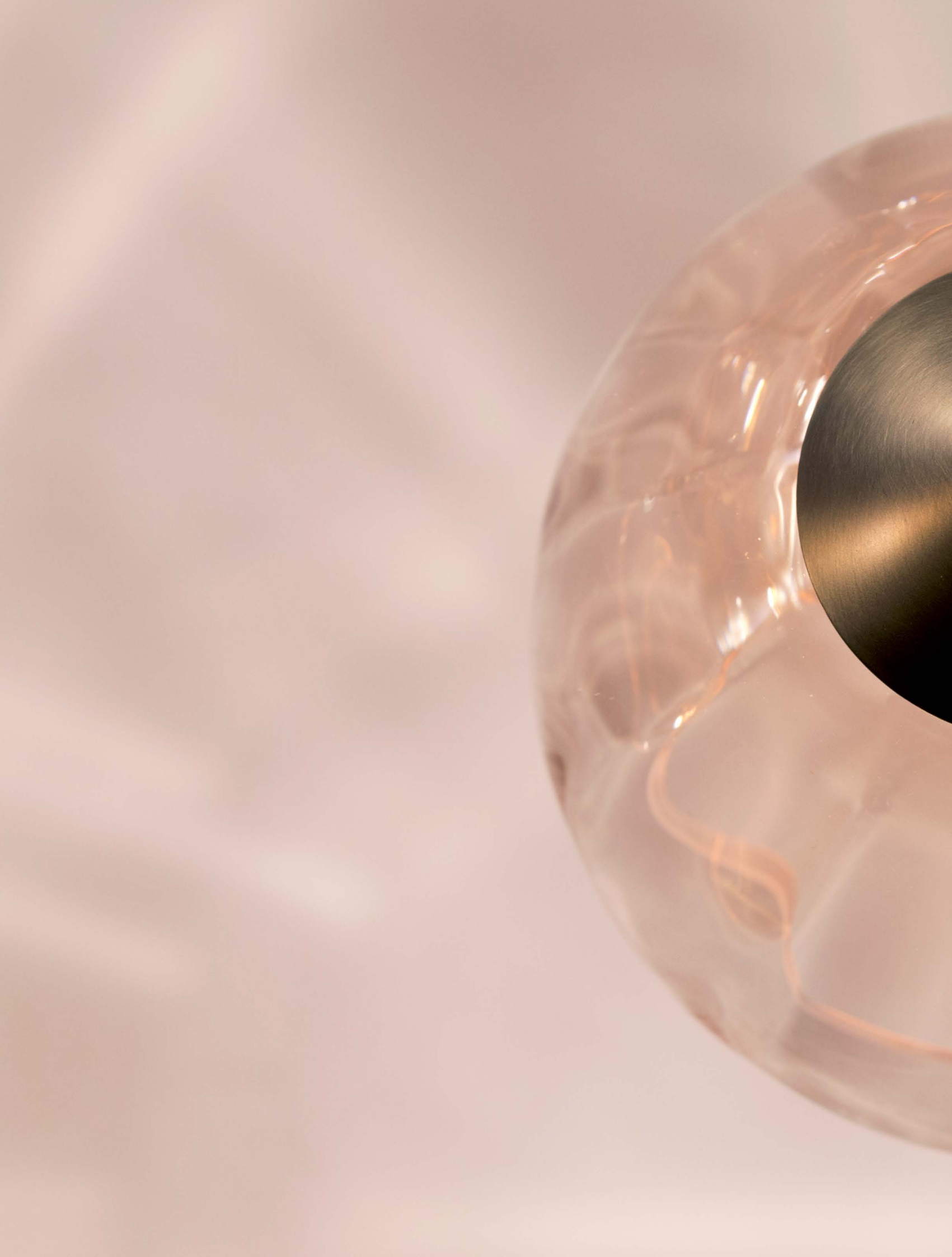



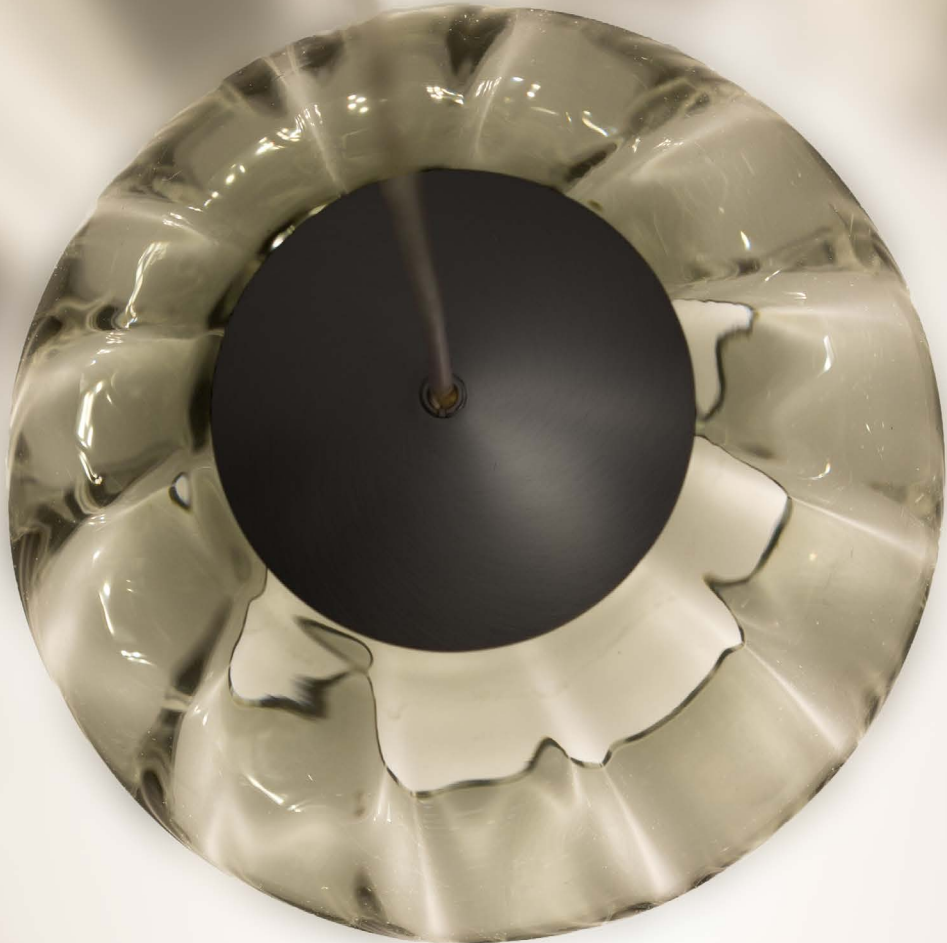

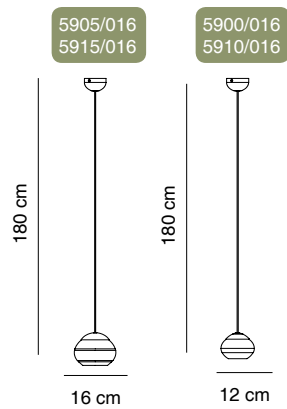
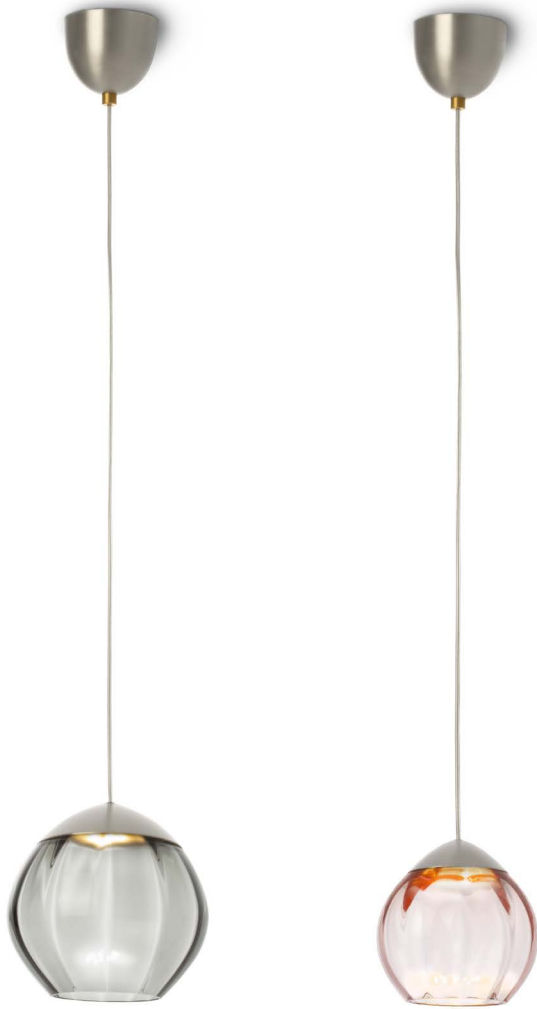

## Soft

Design by Cristian Cubiñá

Pantalla cristal soplado rosado o negro  
**Shade blown glass pink or black**

Estructura hierro níquel satinado.  
**Structure iron satin nickel**

Lámpara incluida, no reemplazable, no regulable  
**Lamp included, not replaceable, not dimmable**

5900/016 cristal pequeño rosado **small pink glass**

5905/016 cristal grande rosado **big pink glass**

5910/016 cristal pequeño negro **small black glass**

5915/016 cristal grande negro **big black glass**

LED Seoul 3W 2700K 372lm

CE  IP20  A+

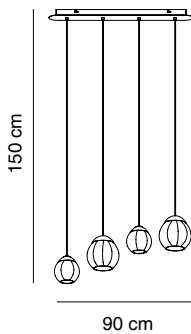

## Soft

Design by Cristian Cubiñá

Pantalla cristal soplado rosado o negro  
**Shade blown glass pink or black**

Estructura hierro níquel satinado.  
**Structure iron satin nickel**

Lámpara incluida, no reemplazable, no regulable  
**Lamp included, not replaceable, not dimmable**

5900/046 cristal rosado **pink glass**

5910/046 cristal negro **black glass**

LED Seoul 3W 2700K 372lm

CE IP 20 A+







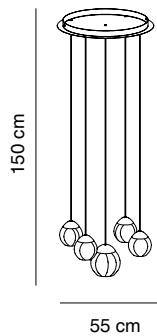

## Soft

Design by Cristian Cubiñá

---

Pantalla cristal soplado rosado o negro  
**Shade blown glass pink or black**

Estructura hierro níquel satinado.  
**Structure iron satin nickel**

Lámpara incluida, no reemplazable, no regulable  
**Lamp included, not replaceable, not dimmable**

---

5900/056 cristal rosado **pink glass**

5910/056 cristal negro **black glass**

LED Seoul 3W 2700K 372lm

---

CE IP 20 A+ 



# CapsuleHat

Design by Cristian Cubiñá

Pantalla cristal opal / hierro  
**Shade opal glass / iron**

Estructura hierro pintado texturado  
**Structure texturized epoxy painted iron**



Lámpara no incluida  
**Lamp not included**

5520/011 blanco **white**

5520/012 corten **corten**

5520/018 antracita **anthracite**

 G9 LED

CE   IP 20  A+

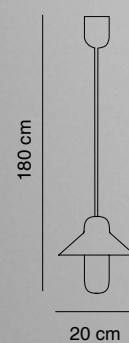



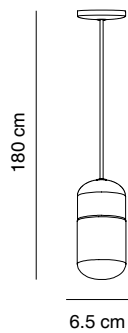

## Capsule

Design by Cristian Cubiñá

---

Pantalla cristal opal  
**Shade opal glass**

Estructura hierro pintado texturado  
**Structure texturized epoxy painted iron**

Lámpara no incluida  
**Lamp not included**

---



5320/011 blanco **white**

5320/012 corten **corten**

5320/018 antracita **anthracite**

 G9 LED

---

CE   







## Moon

Design by Josep Novell & Ernest Perera

---

Estructura hierro pintado blanco texturado  
**Structure iron white textured powder coated**

Pantalla Polietileno rotomoldeado opal  
**Shade white texturized rotomolded polyethylene**

Regulable mediante Triac. Lámpara incluida y no reemplazable  
**Dimming through Triac . Lamp included and not replaceable**

---

5850/011 blanco **white**

LED Epistar 30W + 18W 2700K 4000lm

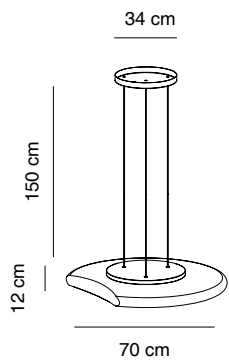

---

CE  IP 23  A+





## SuperMoon

Design by Josep Novell & Ernest Perera

Estructura hierro pintado blanco texturado  
**Structure iron white textured powder coated**

Pantalla Polietileno rotomoldeado opal  
**Shade white texturized rotomolded polyethylene**

Regulable mediante Triac. Lámpara incluida y no reemplazable  
**Dimming through Triac . Lamp included and not replaceable**

5860/041 blanco **white**

4 x LED Epistar 30W + 18W 2700K 4000lm

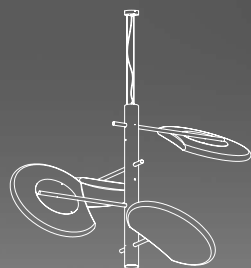

180 cm

200 cm

CE  IP 20 **A+**

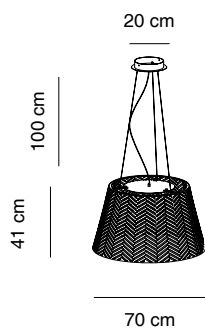

## Spike

Design by Oriol Llahona

Estructura hierro galvanizado pintado blanco texturado

**Structure: Galvanized steel textured white coated**

Pantalla: Hierro galvanizado cortado al láser y pintado blanco texturado

**Shade galvanized laser cut iron textured white coated**

Admite regulación. Lámpara incluida y no reemplazable

**Dimming allowed. Lamp included and not replaceable**

5750/011 blanco **white**

LED 24W 3000K 2500lm

CE  IP 45 **A+**





## Deco

Design by Cristian Cubiñá

Estructura hierro cromado  
**Structure chromed iron**

Pantalla cristal prensado de Bohemia en acabado transparente o degradado ámbar o turquesa  
**Shade Pressed Bohemia crystal transparent glass or gradated amber or turquoise**

Lámpara no incluida  
**Lamp not included**

5550/011 Cromo - Transparente **Chome - Transparent**

5550/012 Cromo - Ambar **Chome - Amber**

5550/015 Como - Turquesa **Chome - Turquoise**

5530/011 Dorado - Transparente **Gold - Transparent**

5530/012 Dorado - Ambar **Gold - Amber**

5530/015 Dorado - Turquesa **Gold - Turquoise**

 G9 LED

CE  IP 20 

13 cm



160 cm

14 cm



28 cm



# Blow

Design by Josep Novell & Ernest Perera

Estructura hierro / latón  
**Structure iron / brass**

Pantalla cristal soplado  
**Blown glass shade**

Lámpara incluida, no reemplazable, no regulable  
**Lamp included and, replaceable, not dimmable**

## SISTEMA DE ILUMINACIÓN MODULAR

Cada módulo (figura A) está preparado para conectarse con el anterior y gracias a su forma permite innumerables combinaciones sólo limitadas por la imaginación del proyectista. Los cristales están diseñados para poder crear un ritmo estético en la luminaria dependiendo de los gustos del cliente. Sólo es necesario un punto de luz para crear una cadena infinita de luminarias. También hay un tramo ciego para poder hacer separaciones de luz, que igualmente se interconecta eléctricamente.

### Modular lighting system

*Each module (figure A) is designed to be connected to the previous one and due to its shape, allows countless combinations limited only by the imagination of the designer. The glasses are designed to create an aesthetic pace according to the customer taste. You only need one power supply to create an endless chain of lights. There is also a blind stretch to make separations of light, which is also electrically interconnected.*



Ejemplos de diferentes soluciones de iluminación modular  
**Examples of several modular lighting solutions**

**i** Curvas fotométricas disponibles en [www.almalight.com](http://www.almalight.com)  
**Photometric curves available on [www.almalight.com](http://www.almalight.com)**

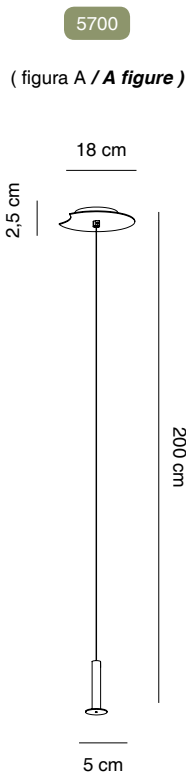
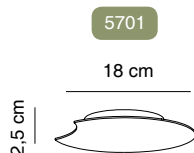



Estructura led sin cristal  
**Led structure without glass**

5700/011 blanco **white**  
5700/016 níquel mate **matt nickel**  
5700/017 cromo **chrome**  
LED Cree 3W – 3000K – 180lm 180°

Estructura ciega sin cristal  
**Blind structure without glass**

5701/011 blanco **white**  
5701/016 níquel mate **matt nickel**  
5701/017 cromo **chrome**

CE   







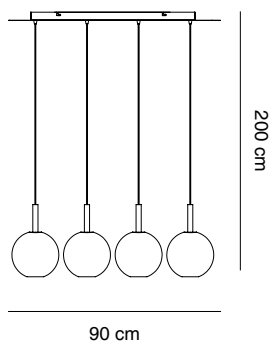
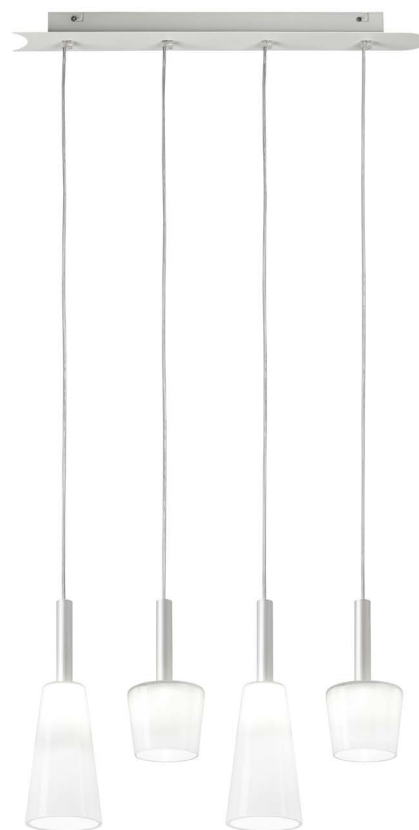

## Blow

Design by Josep Novell & Ernest Perera

Estructura hierro / latón

**Structure iron / brass**

Pantalla cristal soplado no incluida

**Blown glass shade not included**

Lámpara incluida, no reemplazable, no regulable

**Lamp included, not replaceable, not dimmable**

5700/V41 colgante lineal 4 luces blanco para cristales ovales / cónicos  
**linear pendant 4 lights white for oval / conic glasses**

5700/V46 colgante lineal 4 luces níquel para cristales ovales / cónicos  
**linear pendant 4 lights matt nickel for oval / conic glasses**

5700/V47 colgante lineal 4 luces cromo para cristales ovales / cónicos  
**linear pendant 4 lights chrome for oval / conic glasses**

LED Cree 3W 3000K 180lm

CE IP 20 A+

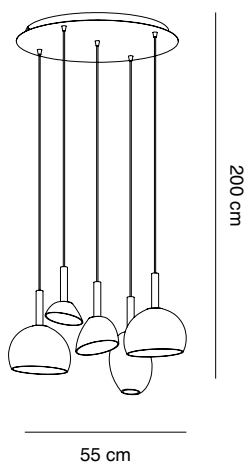

## Blow

Design by Josep Novell & Ernest Perera

Estructura hierro / latón  
**Structure iron / brass**

Pantalla cristal soplado no incluida  
**Blown glass shade not included**

Lámpara incluida, no reemplazable, no regulable  
**Lamp included, not replaceable, not dimmable**

5700/X51 colgante redondo 5 luces blanco para cristales ovales / cónicos  
**round pendant 5 lights white for oval / conic glasses**

5700/X56 colgante redondo 5 luces níquel para cristales ovales / cónicos  
**round pendant 5 lights matt nickel for oval / conic glasses**

5700/X57 colgante redondo 5 luces cromo para cristales ovales / cónicos  
**round pendant 5 lights chrome for oval / conic glasses**

LED Cree 3W 3000K 180lm

CE IP 20 A<sup>+</sup>





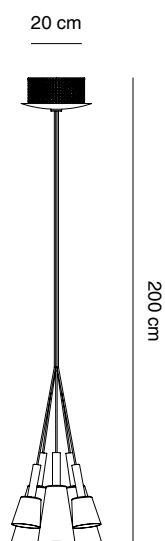

## Blow

Design by Josep Novell & Ernest Perera

Estructura hierro / latón  
**Structure iron / brass**

Pantalla cristal soplado no incluida  
**Blown glass shade not included**

Lámpara incluida, no reemplazable, no regulable  
**Lamp included, not replaceable, not dimmable**

5700/W81 colgante redondo 8 luces blanco para cristales cónicos  
**round pendant 8 lights white for conic glasses**

5700/W86 colgante redondo 8 luces níquel para cristales cónicos  
**round pendant 8 lights matt nickel for conic glasses**

5700/W87 colgante redondo 8 luces cromo para cristales cónicos  
**round pendant 8 lights chrome for conic glasses**

LED Cree 3W 3000K 180lm

CE IP 20 A+





# Blow's glasses

Design by Josep Novell & Ernest Perera

Pantalla cristal soplado  
**Blown glass shade**

Cristales para combinar  
**Glasses to combine**

- 0000/A00 cristal cónico A **A conic glass**
- 0000/B00 cristal cónico B **B conic glass**
- 0000/C00 cristal cónico C **C conic glass**
- 0000/D00 cristal cónico D **D conic glass**
- 0000/E00 cristal oval E **E oval glass**
- 0000/F00 cristal oval F **F oval glass**
- 0000/G00 cristal oval G **G oval glass**
- 0000/H00 cristal oval H **H oval glass**

CE IP 20

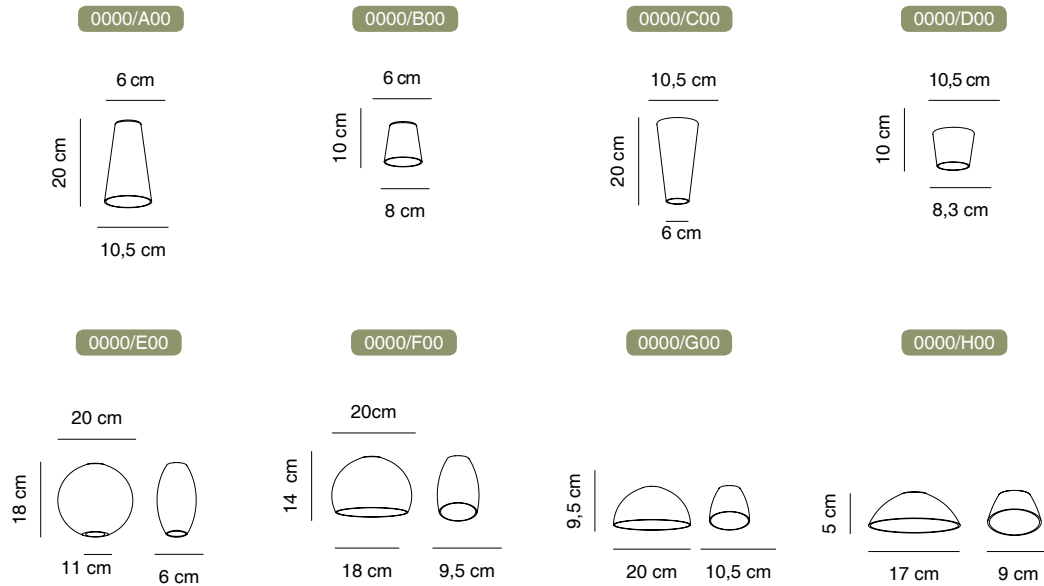





# Led Box

Design by Cristian Cubiñá

Pantalla fundición aluminio pulido  
**Shade polished die cast aluminium**

Cristal transparente arenado  
**Transparent sandblasted glass**

Estructura de acero inoxidable pulido espejo  
**Structure mirror polished stainless steel**

Lamparas incluidas, no reemplazables, no regulable  
**Lamps included and not replaceable, not dimmable**

5080/016 colgante individual **single pendant**

5280/046 colgante lineal 4 luces **linear pendant 4 lights**

5125/066 colgante lineal 6 luces **linear pendant 6 lights**

LED Citizen 3W 2700K 250lm

CE IP 20 A+

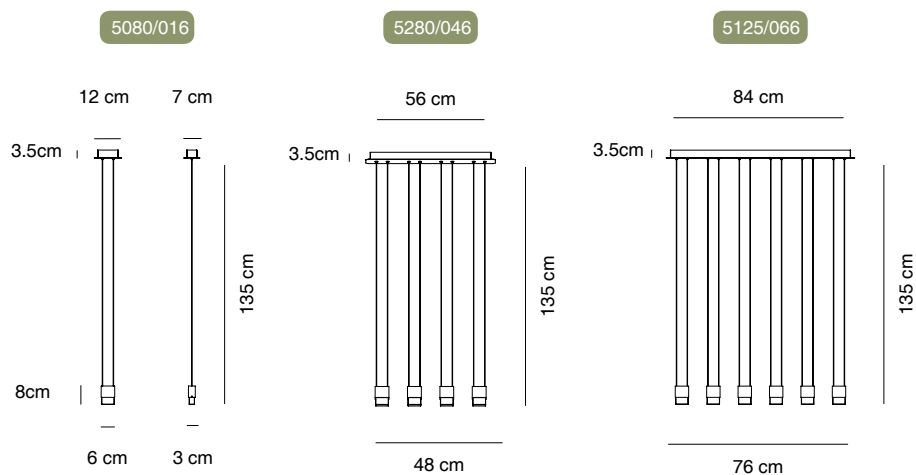
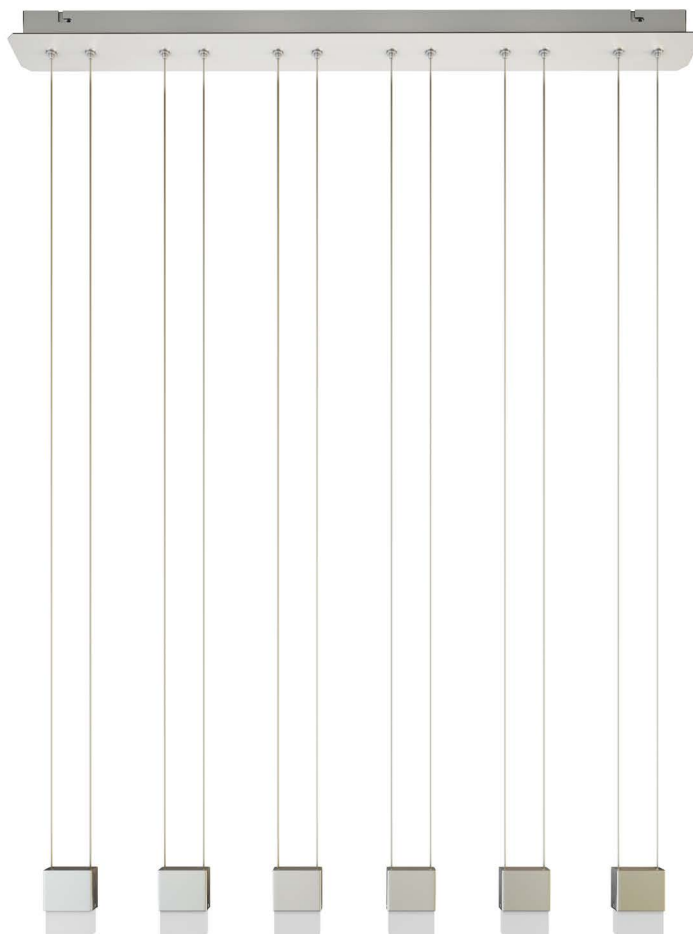







# Led Oval

Design by Cristian Cubiñá

Estructura acero inoxidable pulido espejo  
**Structure mirror polished stainless steel**

Pantalla fundición aluminio pulido  
**Shade polished die cast aluminium**

Lamparas incluidas, no reemplazables, no regulable  
**Lamps included, not replaceable, not dimmable**

5180/017 colgante individual **single pendant**

5180/047 colgante lineal 4 luces **linear pendant  
4 lights**

5180/067 colgante lineal 6 luces **linear pendant  
6 lights**

5185/087 colgante en cruz 8 luces **cross-shaped  
pendant 8 lights**

LED Citizen 3W 2700K 250lm

CE IP 20 A+

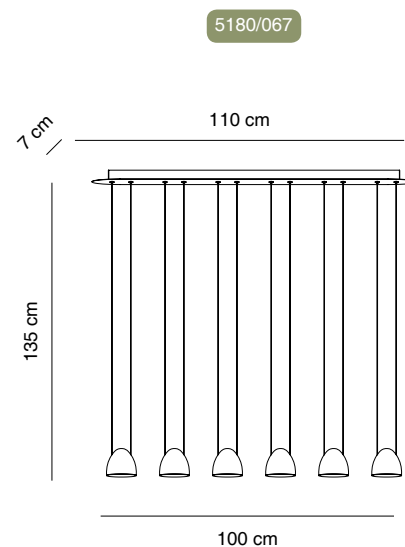
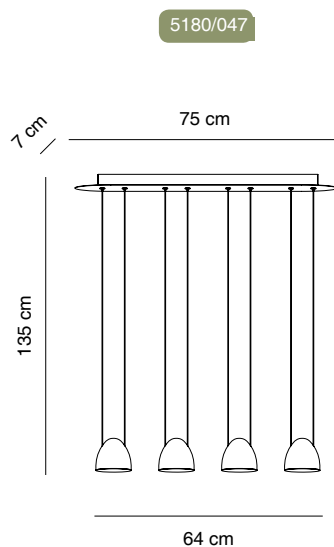
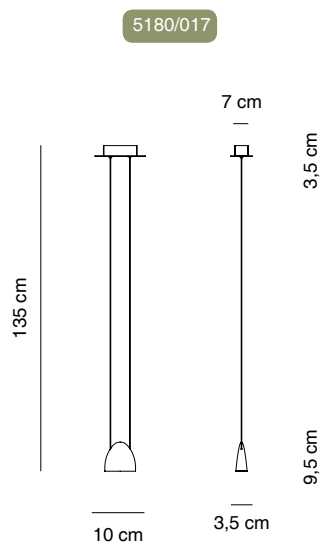
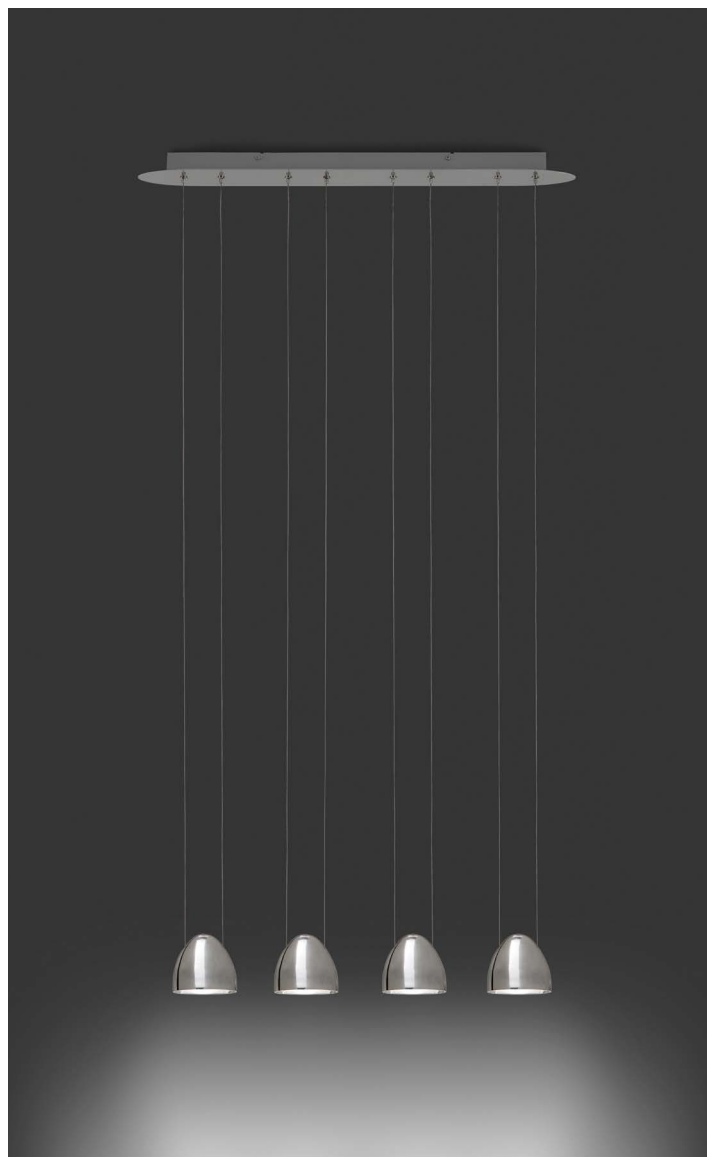









5185/087

75 cm

135 cm

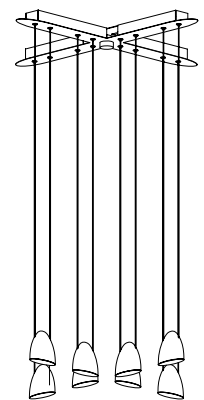

64 cm





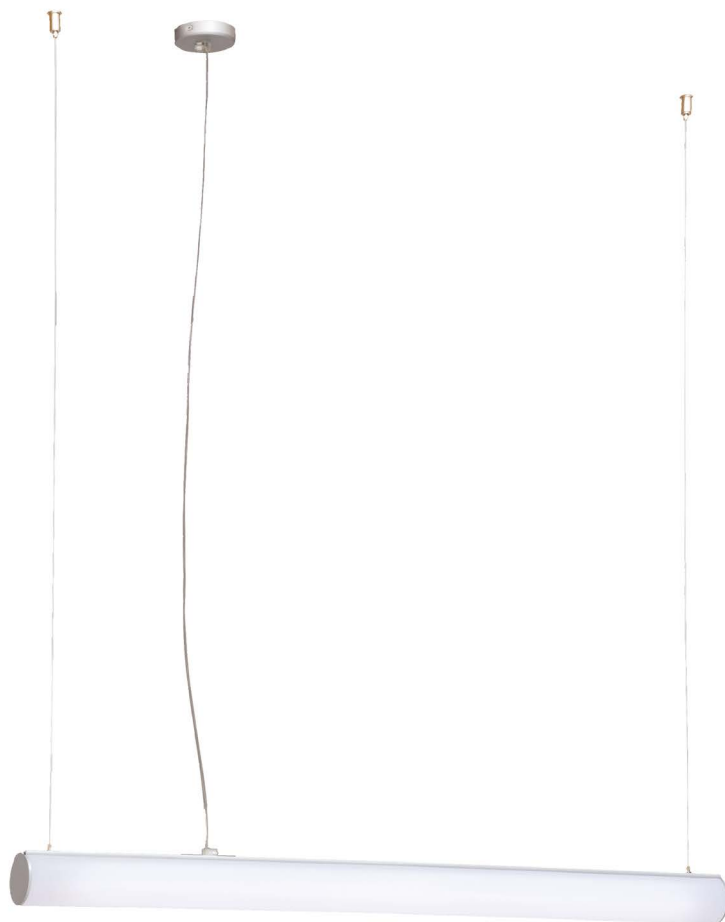

## Bath A Led

Design by Oriol Llahona

Pantalla policarbonato opal  
**Shade opal polycarbonate**

Estructura hierro pintado epoxi  
**Structure epoxy painted iron**

Lámpara incluida no reemplazable. Regulable mediante Triac  
**Lamp included, not replaceable. Dimmable through Triac**

5420/061LED 60cm 18W 1800lm blanco **white**

5420/091LED 90cm 27W 2700lm blanco **white**

5420/121LED 120cm 36W 3600lm blanco **white**

5420/151LED 150cm 45W 4500lm blanco **white**

5420/066LED 60cm 18W 1800lm plata **silver**

5420/096LED 90cm 27W 2700lm plata **silver**

5420/126LED 120cm 36W 3600lm plata **silver**

5420/156LED 150cm 45W 4500lm plata **silver**

Led 3000K

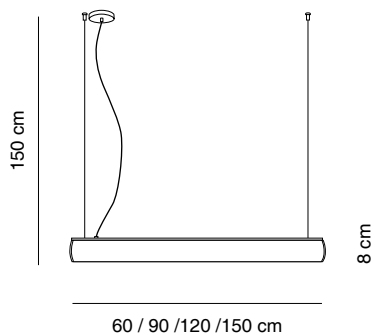

CE IP 23 A+











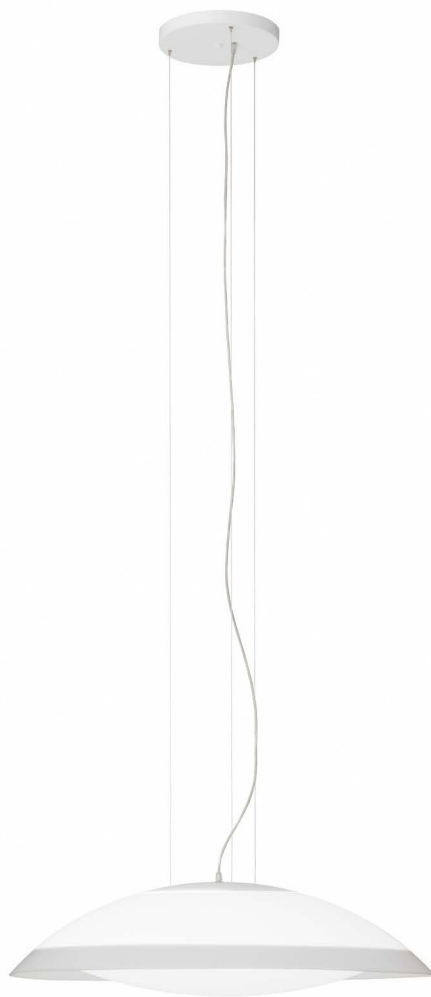

## Lens Led

Design by Cristian Cubiná

Pantalla metacrilato opal **Shade opal methacrylate**

Regulable mediante Triac **Dimmable through Triac**

Lámpara incluida y no reemplazable **Lamp included and not replaceable**

5290/011LED (90cm) blanco **white**

5200/011LED (120cm) blanco **white**

LED Epistar 30W + 18W 4000lm 2700K

CE IP 20 **A+**

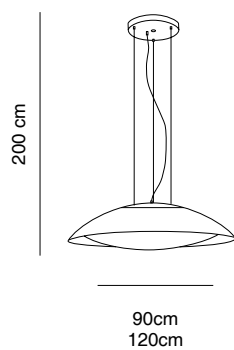



# Biscuit

Design by Javier Taberner & Nacho Poveda

Pantalla cerámica acabada mate  
**Shade matt ceramic**

Estructura hierro pintado blanco con cable textil  
**Structure iron white with textile cable**



Lámparas no incluidas  
**Lamps not included**

5360/011 blanco **white**

5361/011 blanco **white**

5362/011 blanco **white**

 E27 LED

CE  IP 20  A

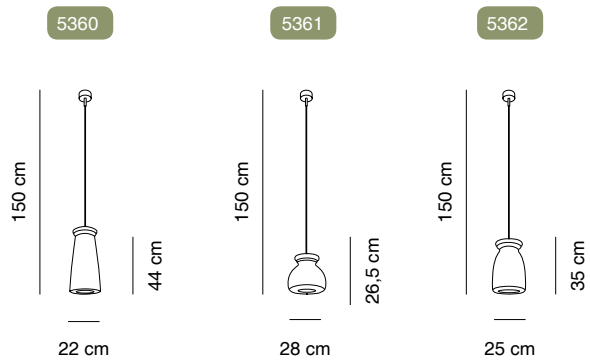



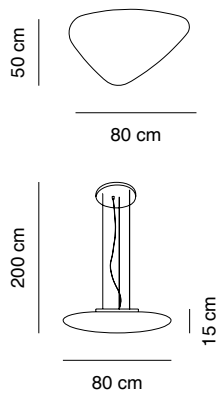

## Stone Led

Design by Josep Puig & Josep Novell

Pantalla polietileno rotomoldeado **Shade rotomoldeado polyethylene**

Estructura hierro pintado epoxi blanco **Structure iron epoxi white painted**

Regulable mediante Triac **Dimmable through Triac**

Lámpara LED incluida y no reemplazable **LED Lamp included and not replaceable**

5300/036LED blanco **white**

LED Epistar 30W + 18W 4000lm 2700K

CE IP 20 A+



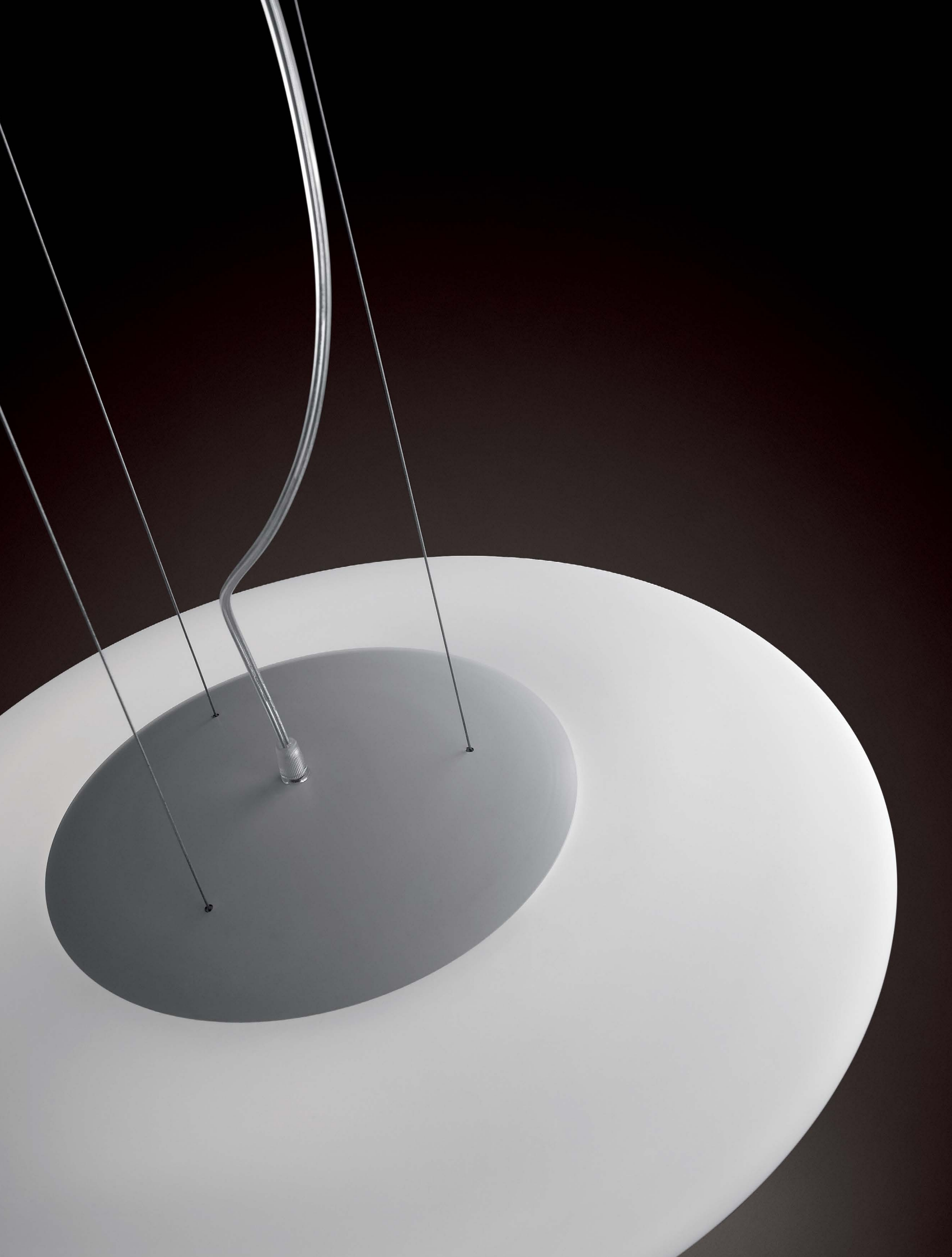



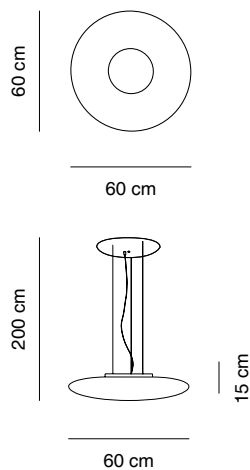
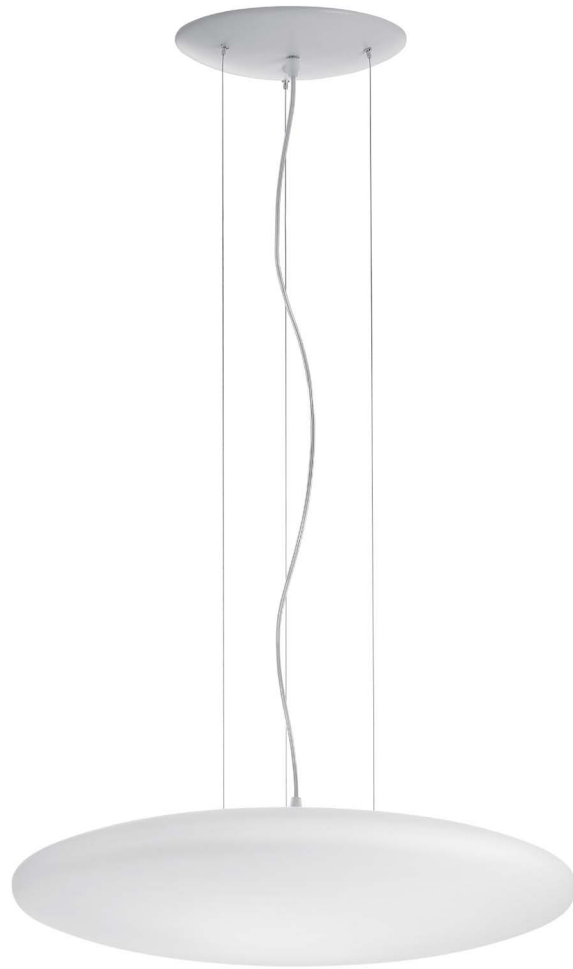

## Sun Led

Design by Josep Puig & Josep Novell

Pantalla cristal opal triplex soplado  
**Shade triplex blown opal glass**



Estructura hierro **Structure iron**

Regulable mediante Triac **Dimmable through Triac**

Lámpara incluida y no reemplazable  
**Lamp included and not replaceable**

5311/016 LED blanco **white**

LED Seoul Acriche 18W 1800lm 2700K

CE   

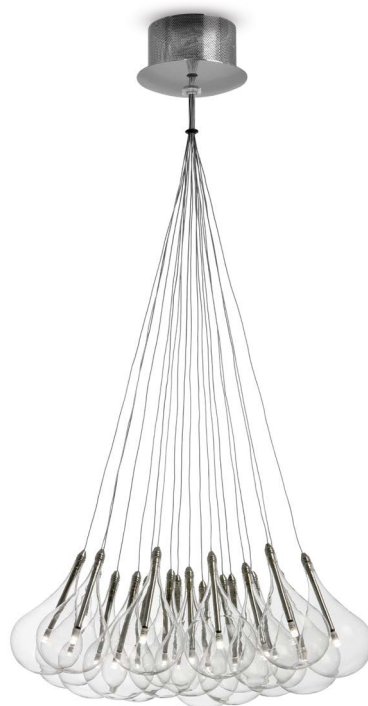

Al subir y bajar el aro de silicona conseguimos variar la forma de luminaria.



**By pulling up or down the silicon ring we can modify the external outfit of the luminaire.**

## Drop Led

Design by Cristian Cubiñá

Pantalla cristal borosilicato transparente  
**Shade borosilicate transparent glass**

Estructura hierro  
**Structure iron**

Cables pueden acortarse máx 60cm  
**Cables can be shortened max. 60cm**

Driver electrónico  
**Electronic driver**

Lámparas Led incluidas, reemplazables, no regulables  
**Led lamps included, replaceable, not dimmable**

Estructura normal largo max.170 - min.110cm  
**Normal structure length max.170 - min.110cm**

5110/196LED cromo **chrome** G4 19x1,5W 110lm 2700K

5110/376LED cromo **chrome** G4 37x1,5W 110lm 2700K

Estructura especial largo 70cm  
**Special structure length 70cm**

5110/196S LED cromo **chrome** G4 19x1,5W 110lm 2700K

5110/376S LED cromo **chrome** G4 37x1,5W 110lm 2700K

Estructura especial largo max.350 - min.290cm  
**Special structure length max.350 - min.290cm**

5110/196XL LED cromo **chrome** G4 19x1,5W 110lm 2700K

5110/376XL LED cromo **chrome** G4 37x1,5W 110lm 2700K

5110/196

16 cm

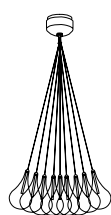

Ø 60 cm

5110/376

20 cm

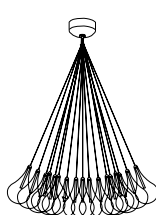

Ø 80 cm

CE IP 20 A++







## Drop Led

Design by Cristian Cubiñá

Pantalla cristal borosilicato transparente  
**Shade borosilicate transparent glass**

Estructura hierro  
**Structure iron**

Driver electrónico  
**Electronic driver**

Lámparas Led incluidas, reemplazables, no regulables  
**Led lamps included, replaceable, not dimmable**

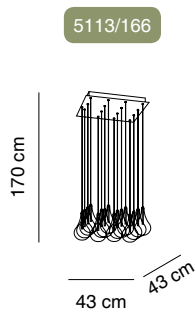
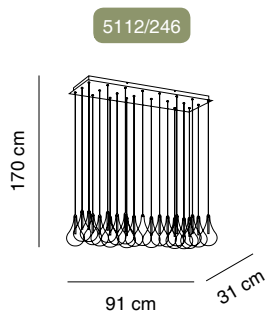

5112/246LED cromo **chrome** G4 24x1,5W 110lm 2700K

5113/166LED cromo **chrome** G4 16x1,5W 110lm 2700K

CE IP 20 A++



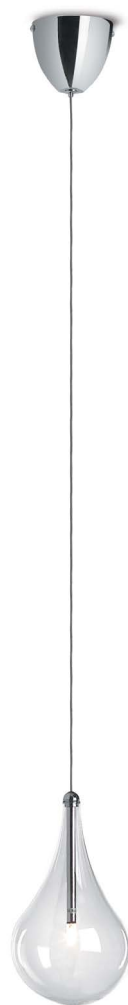

## Drop Led

Design by Cristian Cubiñá

---

Pantalla cristal borosilicato transparente  
**Shade borosilicate transparent glass**

Estructura hierro  
**Structure iron**

Driver electrónico  
**Electronic driver**

Lámpara Led incluida, reemplazable, no regulable  
**Led lamp included, replaceable, not dimmable**

---

5111/016LED cromo **chrome**

 G4 Led 1,5W 110lm 2700K

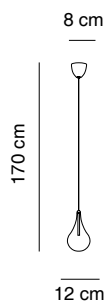

---

CE IP 20









5008/016



5009/016



## Double

Design by Sam Mey

Pantalla cristal opal transparente  
**Shade opal/transparent glass**

El cliente final puede elegir si quiere o no montar  
el cristal transparente exterior  
**The end consumer can choose whether he wants  
or not to install the exterior transparent glass**

Lámpara incluida y reemplazable  
**Lamp included and replaceable**

Transformador electrónico  
**Electronic transformer**

Estructura hierro  
**Structure iron**

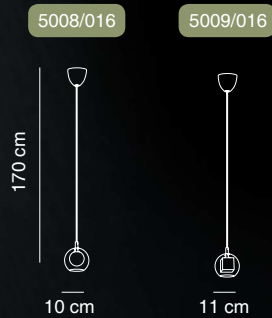

5008/016 níquel mate **matt nickel**

 G4 12V 20W

5009/016 níquel mate **matt nickel**

 G4 12V 20W

CE  

# Plafones

# Ceiling Lamps

Bath A Led / Deco / Drop S Led / Drop Downlight / Lens Led / Mizu / Moon /  
Stone Led / Sun Led / SuperMoon / Tribeca







## Tribeca Downlight

Design Jordi LLopis

Pantalla alabastro  
**Shade alabaster**

Estructura hierro pintado negro texturado  
**Structure black textured epoxy painted iron**

Driver incluido regulable mediante Triac. **Driver included, dimmable through Triac**

Lámpara incluida y no reemplazable  
**Lamp included and not replaceable**

9800/018 negro **black**

LED Seoul 4,5W 2700K 270lm

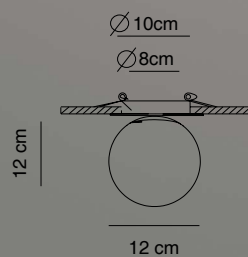

CE IP 20  **A+**







## Drop S Led

Design by Cristian Cubiñá

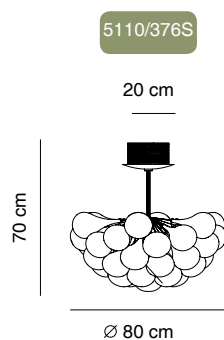
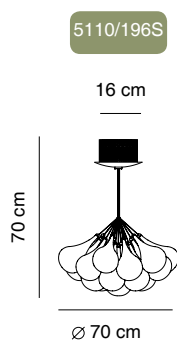

Pantalla cristal borosilicato transparente  
**Shade borosilicate transparent glass**

Estructura hierro / **Structure iron**

Driver electrónico  
**Electronic driver**

Lámparas Led incluidas, reemplazables, no regulables  
**Led lamps included, replaceable, not dimmable**

5110/196S LED cromo **chrome** 19x G4 1,5W 110lm 2700K

5110/376S LED cromo **chrome** 37x G4 1,5W 110lm 2700K

CE IP 20 A+





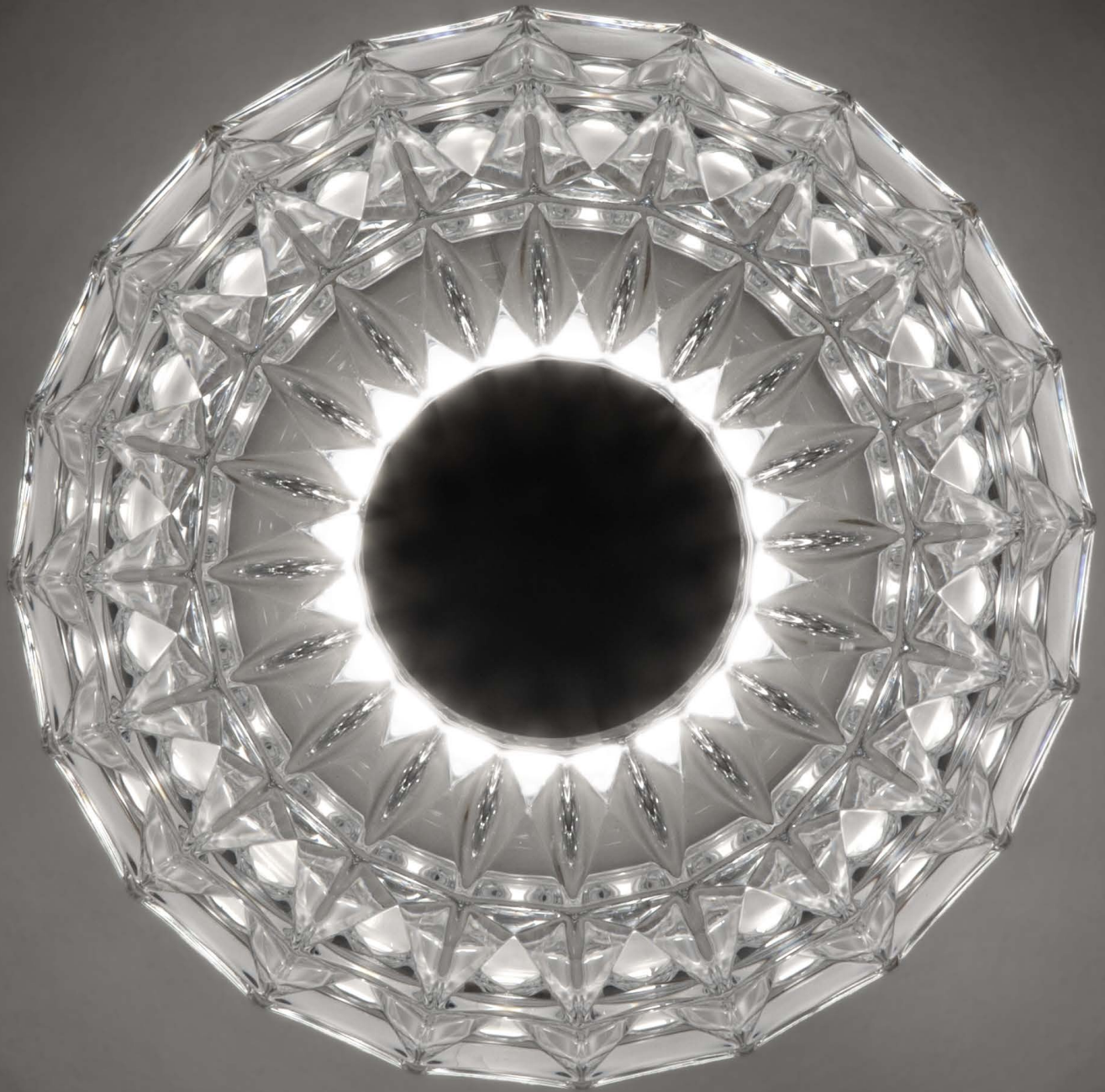



## Deco

Design by Cristian Cubiñá

Estructura hierro cromado  
**Structure chromed iron**

Pantalla cristal prensado de Bohemia en acabado transparente o degradado ámbar o turquesa  
**Shade pressed Bohemia crystal transparent glass or gradated amber or turquoise**

Lámpara no incluida  
**Lamp not included**

9550/011 Cromo - Transparente **Chome - Transparent**

9550/012 Cromo - Ambar **Chome - Amber**

9550/015 Como - Turquesa **Chome - Turquoise**

9530/011 Dorado - Transparente **Gold - Transparent**

9530/012 Dorado - Ambar **Gold - Amber**

9530/015 Dorado - Turquesa **Gold - Turquoise**

 E14 LED

CE  IP 20 

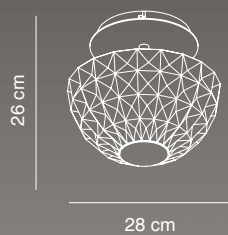







## Moon

Design by Josep Novell & Ernest Perera

Estructura hierro pintado epoxi blanco  
**Structure iron white powder coated**

Pantalla polietileno rotomoldeado texturado  
**Shade rotomolded polyethylene textured**

Regulable mediante Triac. Lámpara incluida y no reemplazable  
**Dimming through Triac. Lamp included and not replaceable**

9850/011 blanco **white**

LED Epistar 30W + 18W 2700K 4000lm

12 cm



70 cm

CE   







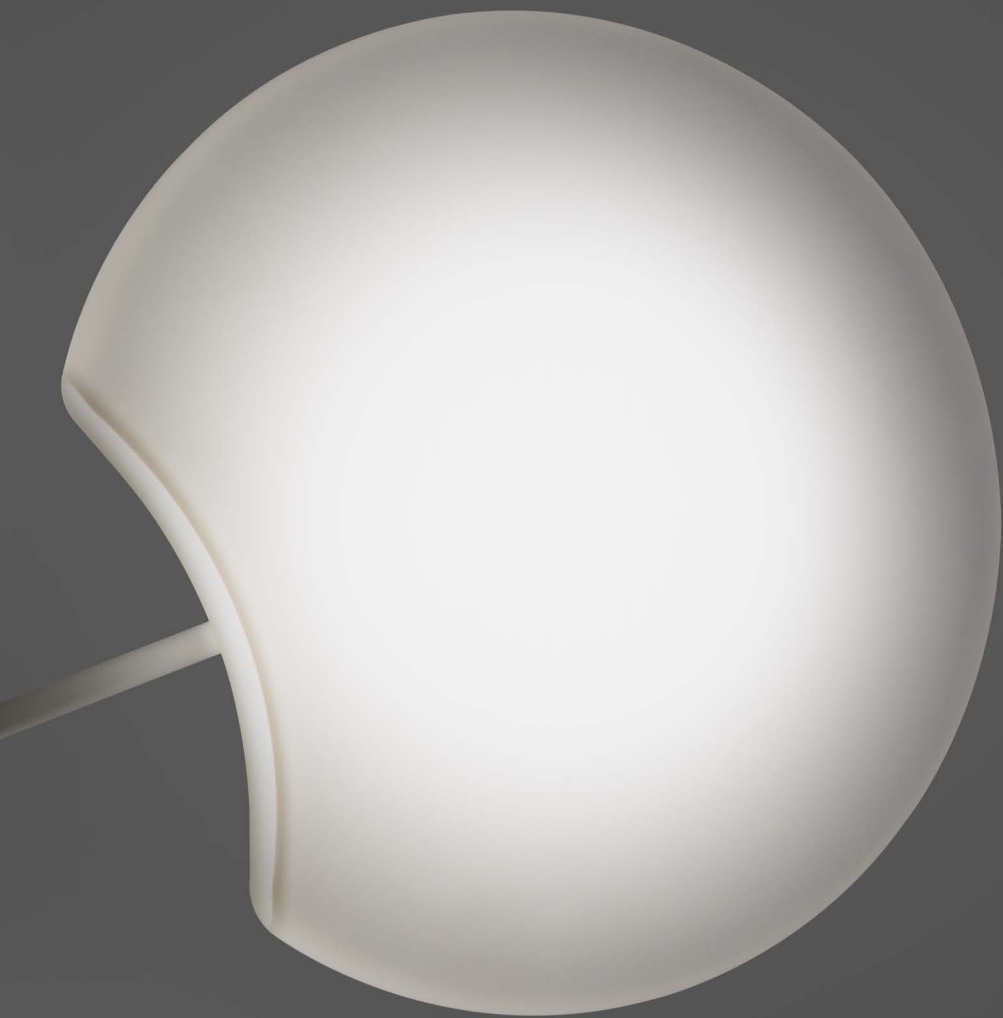

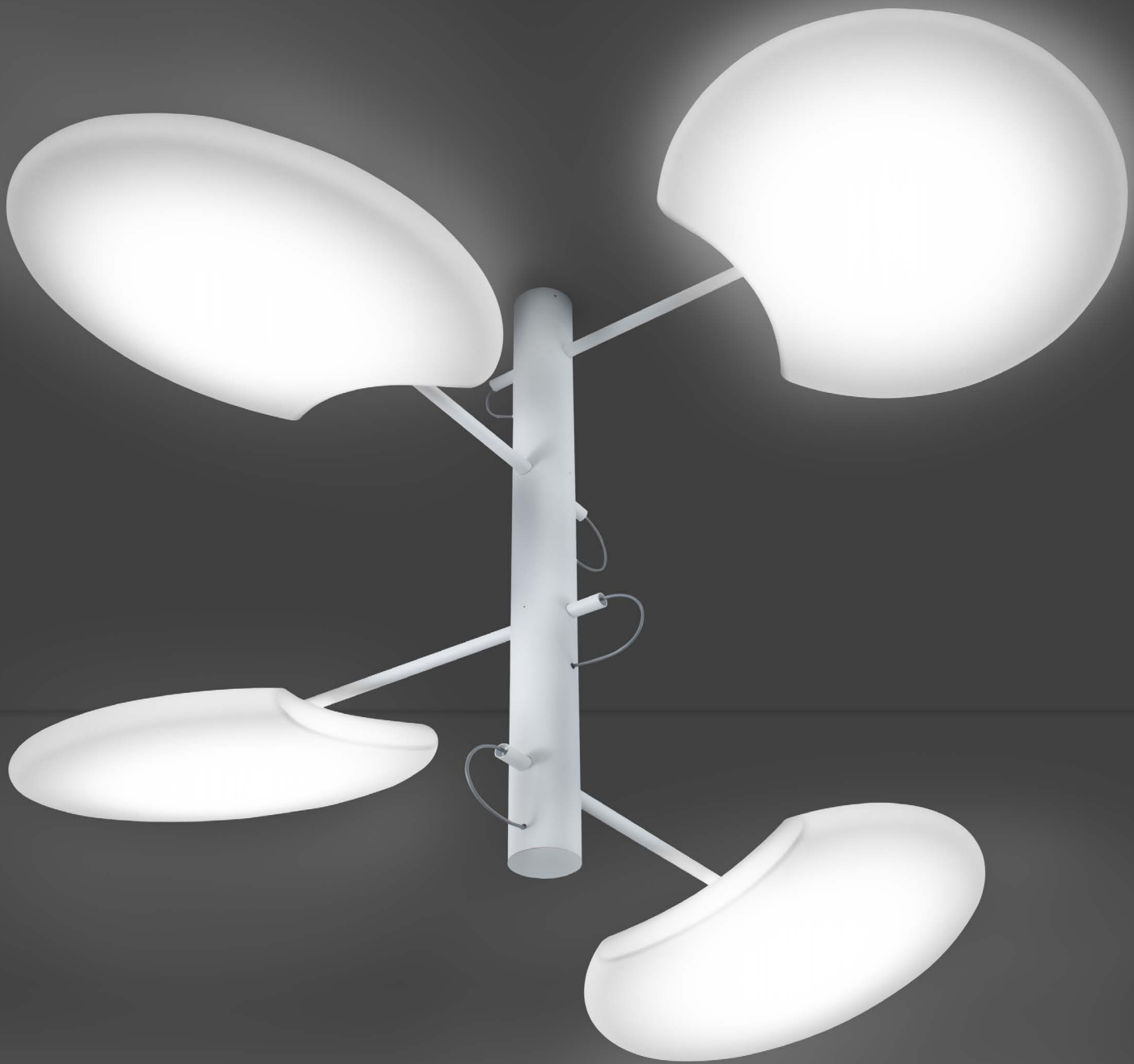

## SuperMoon

Design by Josep Novell & Ernest Perera

Estructura hierro pintado blanco texturado  
**Structure iron white textured powder coated**

Pantalla polietileno rotomoldeado opal  
**Shade white textured rotomolded polyethylene**

Regulable mediante Triac. Lámpara incluida y no reemplazable  
**Dimming through Triac . Lamp included and not replaceable**

9860/041 blanco **white**

4 x LED Epistar 30W + 18W 2700K 4000lm

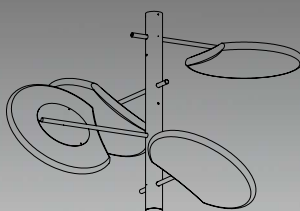

128 cm

200 cm

CE  IP 23  A+







## Stone Led

Design by Josep Novell & Josep Puig

Pantalla polietileno rotomoldeado  
**Shade rotomolded polyethylene**

Estructura hierro pintado epoxi blanco  
**Structure iron epoxy white painted**

Regulable mediante Triac **Dimmable through Triac**

Lámpara LED incluida y no reemplazable  
**LED lamp included and not replaceable**

9300/036LED blanco **white**

LED Epistar 30W + 18W 4000lm 2700K

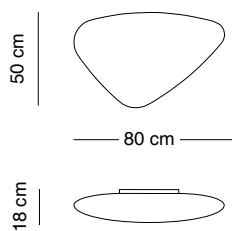

CE  IP 20  A+



## Bath A Led

Design by Oriol Llahona

Pantalla policarbonato opal  
**Shade opal polycarbonate**

Estructura hierro pintado epoxi  
**Structure epoxy painted iron**

Lámpara incluida, no reemplazable, regulable mediante Triac  
**Lamp included, not replaceable, dimmable through Triac**

4420/061LED 18W 1800lm 60 cm blanco **white**  
4420/091LED 27W 2700lm 90 cm blanco **white**  
4420/121LED 36W 3600lm 120 cm blanco **white**  
4420/151LED 45W 4500lm 150 cm blanco **white**

4420/066LED 18W 1800lm 60 cm plata **silver**  
4420/096LED 27W 2700lm 90 cm plata **silver**  
4420/126LED 36W 3600lm 120 cm plata **silver**  
4420/156LED 45W 4500lm 150 cm plata **silver**

Led 3000K

8 cm



60cm  
90 cm  
120 cm  
150cm

CE IP 23 A+





# Mizu

Design by Ricard Ferrer

Pantalla cristal triplex opal  
**Shade opal blown glass**

Estructura hierro pintado epoxi/aro aluminio  
**Structure iron epoxy painted/aluminium ring**

Lámpara no incluida  
**Lamp not included**

9282/011 blanco **white**

9282/016 plata **silver**

9283/011 blanco **white**

9283/016 plata **silver**



9280/011 blanco **white**

9280/016 plata **silver**

9281/011 blanco **white**

9281/016 plata **silver**

 G9 LED

CE  IP 23  A+

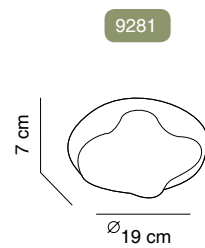
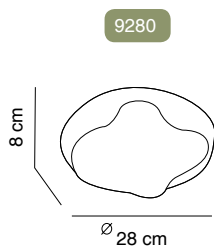
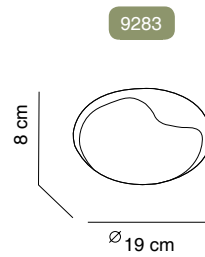
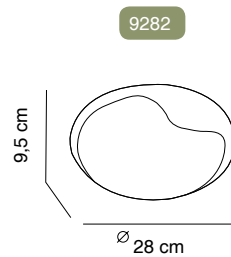









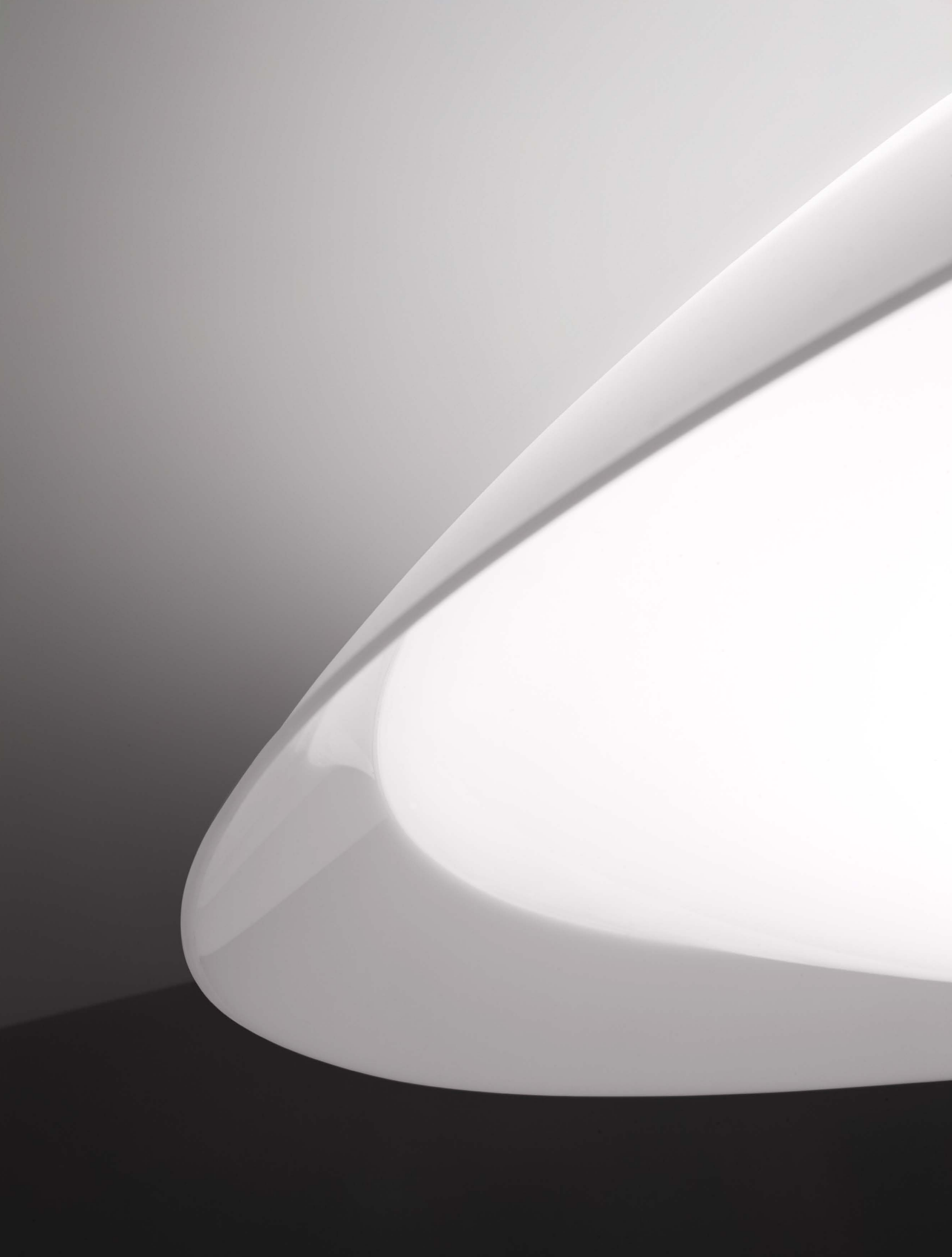



## Lens Led

Design by Cristian Cubiná

Pantalla de metacrilato blanco  
*Shade opal methacrylate*

Estructura hierro pintado epoxi *Structure epoxy  
painted iron*

Regulable mediante Triac *Dimmable through  
Triac*

Lámpara LED incluida y no reemplazable  
*LED lamp included and not replaceable*

9290/011LED (90cm) blanco *white*

9200/011LED (120cm) blanco *white*

LED Epistar 30W +18W 4000lm 2700K

CE   

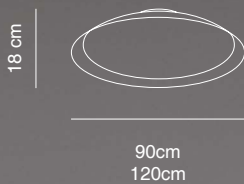



## Sun Led

Design by Josep Novell & Josep Puig

---

Pantalla cristal opal triplex soplado  
**Shade triplex blown opal glass**

Estructura hierro **Structure iron**

Lámpara incluida y no reemplazable  
**Lamp included and not replaceable**

Regulable mediante Triac **Dimmable through Triac**

Montaje posible en pared o techo  
**Possible installation on wall or ceiling**

---

9309/016 LED (60cm) blanco **white**

LED Seoul Acriche 18W 1800lm 2700K

---

CE  IP 20  A+

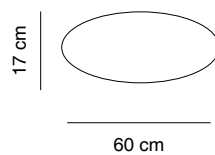





## Drop Downlight Led

Design Cristian Cubiñá

Pantalla cristal borosilicato transparente  
**Shade borosilicate transparent glass**

Foco empotrado / Estructura hierro  
**Embedded downlight / Structure iron**

Driver incluido  
**Driver included**

Lámpara incluida, no regulable y reemplazable  
**Lamp included, not dimmable and replaceable**

9111/016 LED cromo **chrome**

LED G4 1,5W 110lm 2700K

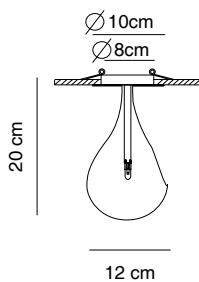

CE IP20 





# Apliques

# Wall Lamps

Bath A Led / Deco / Flat Led / Hotel / Madame / MiniFlat / Mizu / Note / Paros  
Alabaster / Square / Tribeca









## Tribeca

Design by Jordi Llopis

Pantalla alabastro  
**Shade alabaster**

Estructura hierro pintado negro texturado  
**Structure black texturized epoxy painted iron**

Interruptor para el lector **Switch for the reading light**

Lámpara incluida y no reemplazable  
**Lamp included and not replaceable**

4800/028 negro, un interruptor **black, one switch**

LED Seoul 4.5W 2700K 270lm  
LED Cree 3W 3000K 260lm 30°



CE IP 20

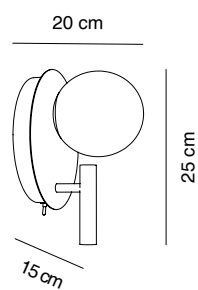











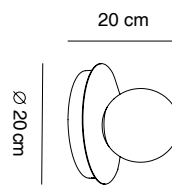

## Tribeca

Design by Jordi LLopis

---

Pantalla alabastro

**Shade alabaster**

Estructura hierro pintado negro texturado

**Structure black texturized epoxy painted iron**

Regulable mediante Triac. Sin interruptor. Lámpara incluida y no reemplazable

**Dimming through Triac . Without switch. Lamp included and not replaceable**

---

4800/018 negro **black**

LED Seoul 4.5W 2700K 270lm

---

CE IP 20 A+ 



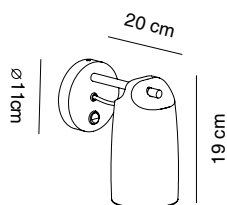

## Paros Alabaster

Design by Josep Novell & Ernest Perera

Pantalla **alabastro**  
**Shade alabaster**

Estructura hierro pintado blanco texturado  
**Structure texturized white painted iron**

Con interruptor With switch

Lámpara no incluida, reemplazable  
**Lamp not included, replaceable**

4270/011 blanco **white**

 E14 LED

CE  IP 20  A<sup>+</sup>



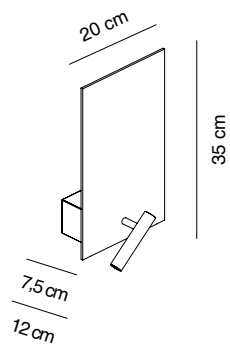

## Flat Led

Design by Josep Novell & Ernest Perera

Estructura hierro  
**Structure iron**

Con interruptor para el lector o dos interruptores. Lámpara LED incluida en el lector, no reemplazable

**With switch for the reading light or two switches.  
LED lamp included for the reading light, not replaceable**

4416/011 blanco, un interruptor **white, one switch**  
4416/211 blanco, dos interruptores **white, two switches**

 E27 LED  
LED Cree 3W 3000K 260lm 30°



CE IP 20









4419

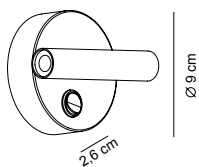

4414

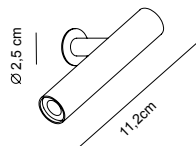

4413

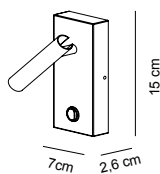

## MiniFlat

Design by Cristian Cubiñá

Estructura hierro  
**Structure iron**

Con driver, lámpara LED incluida, no reemplazable  
**With Driver, LED lamp included, not replaceable**

4419/011 blanco **white**

4419/016 níquel mate **matt nickel**



4413/011 blanco **white**

4413/016 níquel mate **matt nickel**

4414/011 blanco **white**

4414/016 níquel mate **matt nickel**

LED Cree 3W 3000K 260lm 30°

CE   

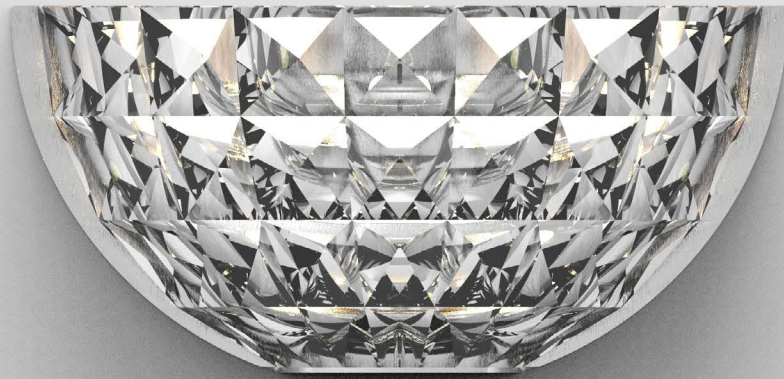

## Deco

Design by Cristian Cubiñá

Estructura hierro cromado  
**Structure chromed iron**

Pantalla cristal prensado de Bohemia en acabado transparente o degradado ámbar o turquesa  
**Shade Pressed Bohemia crystal in transparent finish, or gradated amber or turquoise**

Lámpara no incluida  
**Lamp not included**

4550/011 Cromo -Transparente **Chome - Transparent**

4550/012 Cromo - Ambar **Chome - Amber**



4550/015 Como - Turquesa **Chome - Turquoise**

4530/011 Dorado -Transparente **Gold - Transparent**

4530/012 Dorado - Ambar **Gold - Amber**

4530/015 Dorado - Turquesa **Gold - Turquoise**

 2 x G9 LED

CE   

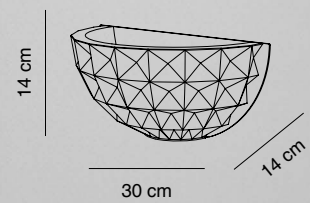





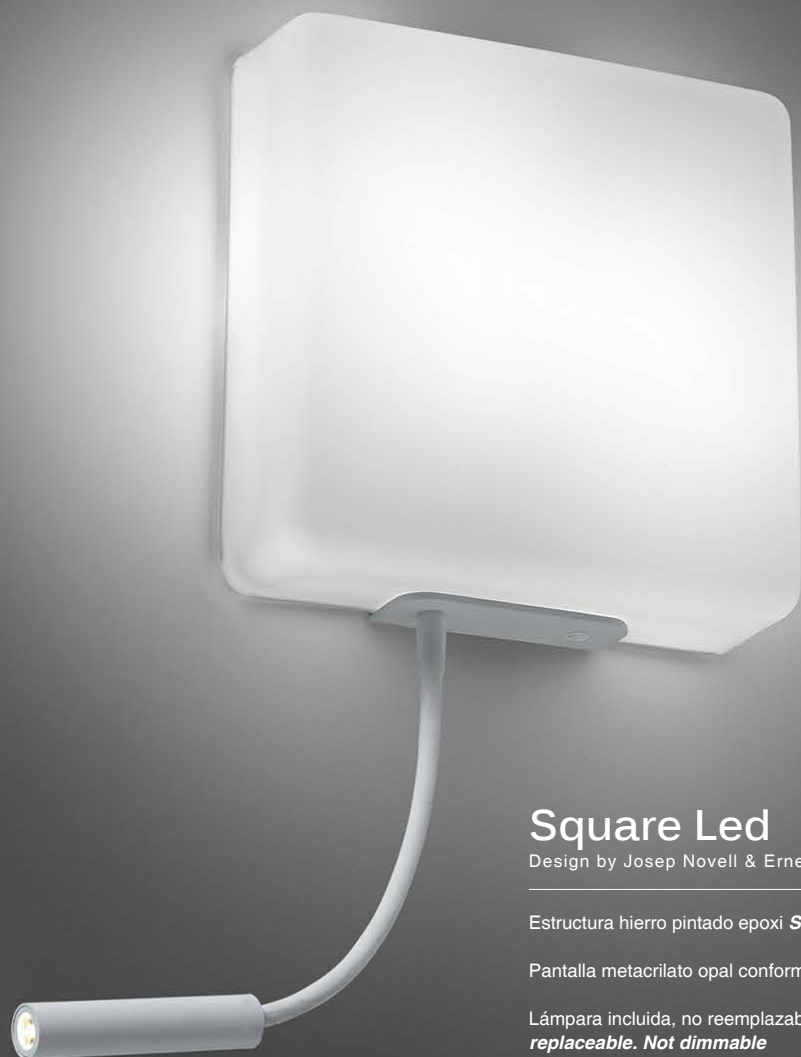

## Square Led

Design by Josep Novell & Ernest Perera

Estructura hierro pintado epoxi **Structure powder coated iron**

Pantalla metacrilato opal conformado **Shade formed opal methacrylate**

Lámpara incluida, no reemplazable, no regulable **Lamp included, not replaceable. Not dimmable**

Con interruptor para el lector. Lámpara LED incluida, no reemplazable **With switch for the reading light. LED lamp included, not replaceable**

Con lector  
**With reading light**

4046/011 blanco **white**

4046/016 plata **silver**

Led Epistar 22W 3000K 1700lm

LED Cree 3W 3000K 260lm 30°

Sin lector  
**Without reading light**

4047/011 blanco **white**

4047/016 plata **silver**

Led Epistar 22W 3000K 1700lm

CE  IP 20  **A+**

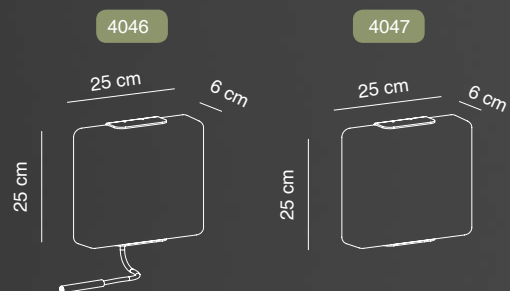

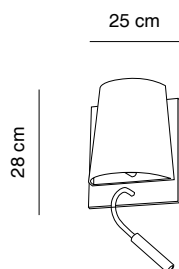

## Hotel

Design by Cristian Cubiñá

Pantalla algodón negra

**Shade black cotton**

Estructura hierro pintado epoxi

**Structure iron epoxi painted**

Con interruptor para el lector

**With switch for the reading light**

Lámpara LED 4000K incluida, no reemplazable  
**3W 4000K LED lamp included, not replaceable**

4540/018 champagne/negro **champagne/black**

 E27 LED + LED 3W 4000K 30°

**A** **A+**







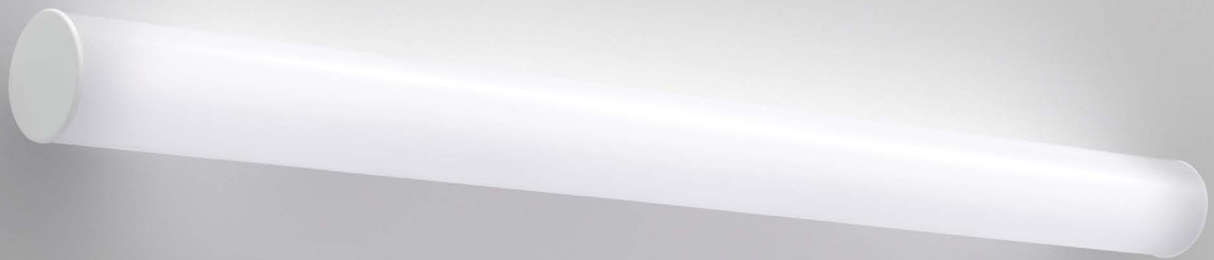

60cm  
90cm  
120cm  
150 cm



## Bath A Led

Design by Oriol Llahona

Pantalla policarbonato opal  
**Shade opal polycarbonate**

Estructura hierro pintado epoxi  
**Structure epoxy painted iron**

Lámpara incluida, no reemplazable, regulable mediante Triac  
**Lamp included, not replaceable, dimmable through Triac**

4420/061LED 18W 1800lm 60 cm blanco **white**  
4420/091LED 27W 2700lm 90 cm blanco **white**  
4420/121LED 36W 3600lm 120 cm blanco **white**  
4420/151LED 45W 4500lm 150 cm blanco **white**

4420/066LED 18W 1800lm 60 cm plata **silver**  
4420/096LED 27W 2700lm 90 cm plata **silver**  
4420/126LED 36W 3600lm 120 cm plata **silver**  
4420/156LED 45W 4500lm 150 cm plata **silver**

Led 3000K

CE IP 23 A+





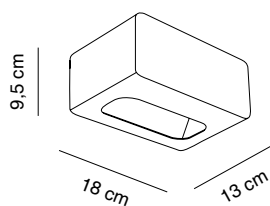
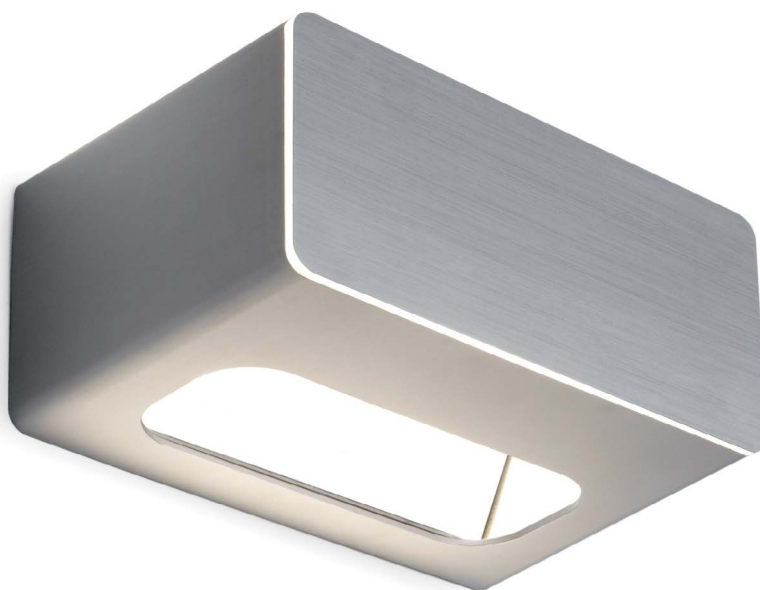

## Note

Design by Oriol Llahona

Estructura aluminio anodizado o pintado epoxi texturizado

**Structure anodized or texturized epoxy painted aluminium**

Pantalla cristal óptico arenado

**Shade sandblasted optic glass**

Lámpara no incluida

**Lamp not included**



4900/011 blanco **white**

4900/015 rojo **red (ral 3020)**

4900/016 anodizado plata **silver anodized**

4900/018 negro **black**

 R7s LED

CE   IP 20  A+

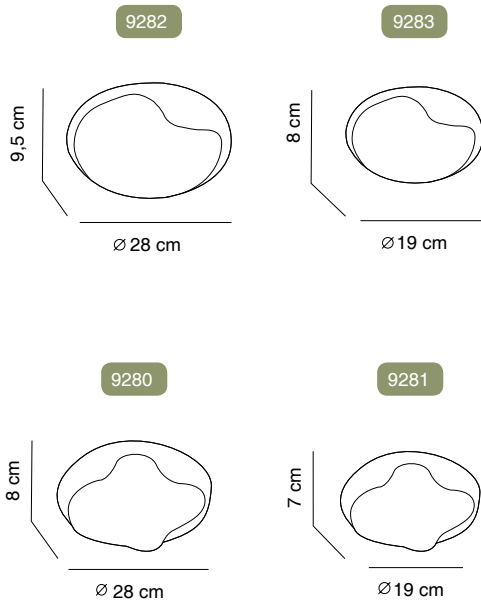

## Mizu

Design by Ricard Ferrer

Pantalla cristal triplex opal  
**Shade opal blown glass**

Estructura hierro pintado epoxi/aro aluminio  
**Structure iron epoxy painted/aluminium ring**

Lámpara no incluida  
**Lamp not included**

9282/011 blanco **white**

9282/016 plata **silver**

9283/011 blanco **white**

9283/016 plata **silver**



9280/011 blanco **white**

9280/016 plata **silver**

9281/011 blanco **white**

9281/016 plata **silver**

 G9 LED

CE  IP23 

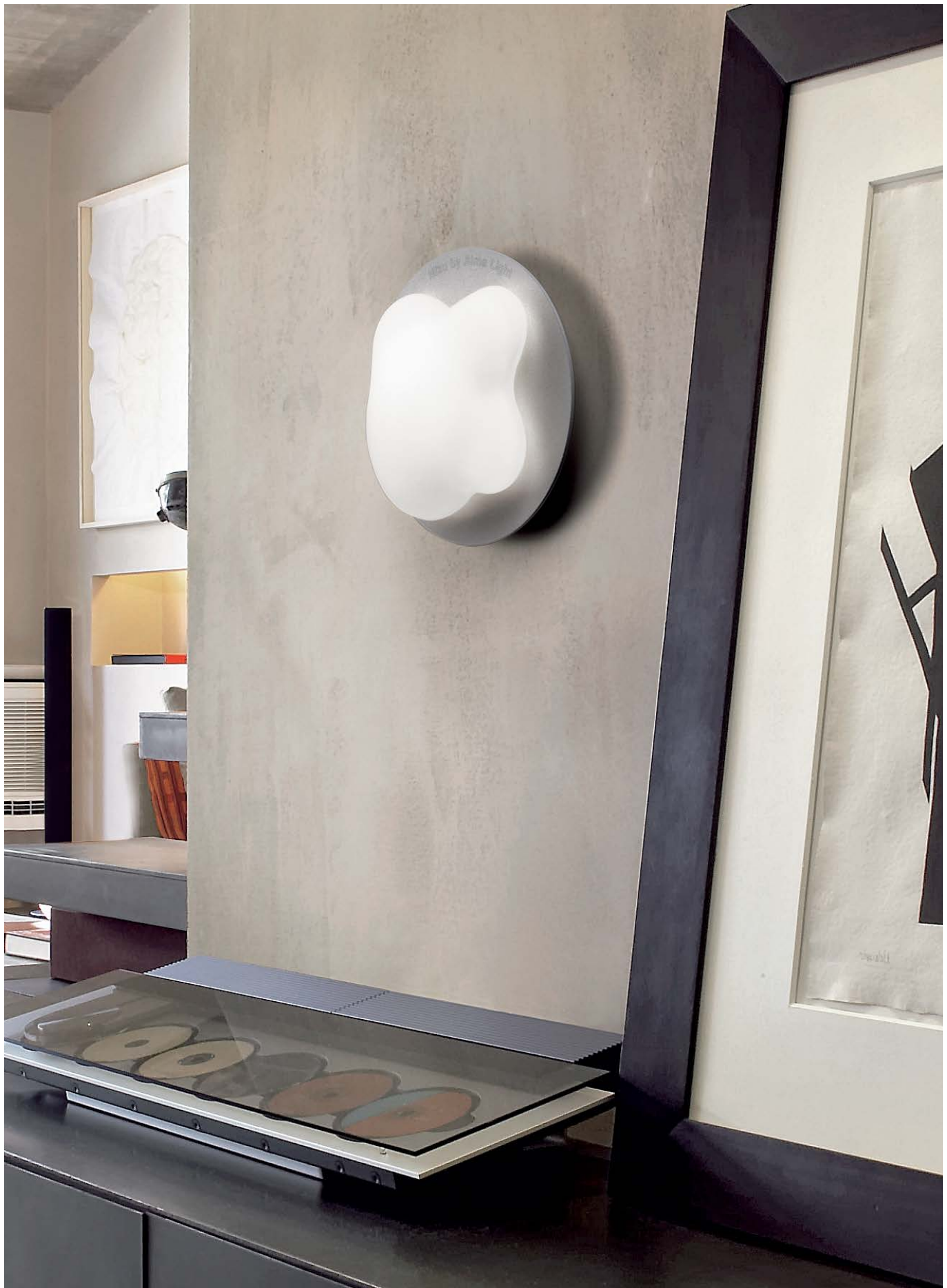











4650/016 4650/018

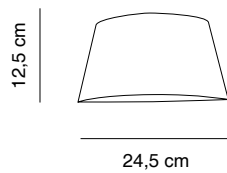

## Madame

Design by Oriol Llahona

---

Pantalla hierro pintado epoxi  
**Shade iron epoxi painted**

Estructura hierro pintado epoxi  
**Structure iron epoxi painted**

Lámpara no incluida / Con interruptor  
**Lamp not included / With switch**



---

4650/016 blanco plata **white silver**

4650/018 negro dorado **black gold**

 G9 LED

---

CE   

# Exterior Outdoor

Spike / Stone Out Led / Tiny









## Spike

Design by Oriol Llahona

Estructura hierro galvanizado pintado blanco texturado  
**Structure: Galvanized steel textured white coated**

Pantalla: Hierro galvanizado cortado al láser y pintado blanco texturado  
**Shade galvanized laser cut iron textured white coated**

Lámpara incluida y no reemplazable  
**Lamp included and not replaceable**

5750/011 blanco **white**  
LED 24W 3000K 2500lm

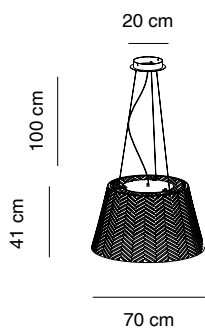

CE  IP 45  A+











## Tiny

Design by Jose Novell & Josep Puig

Estructura latón acabado níquel  
**Structure brass satin nickel finished**



Pantalla polietileno rotomoldeado / Lámpara no incluida  
**Shade rotomolded polyethylene/Lamp not included**

4370/016 níquel satinado **satin nickel**

4371/016 níquel satinado **satin nickel**

4372/016 níquel satinado **satin nickel**

 E27 LED

CE  

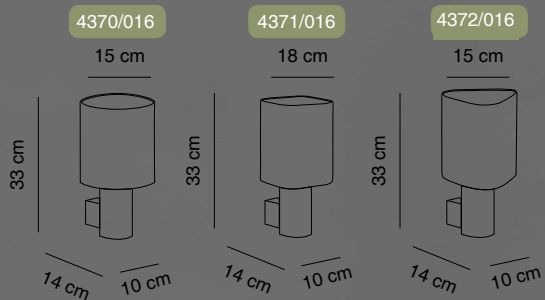

## Tiny

Design by Josep Novell & Josep Puig

Estructura latón acabado níquel  
**Structure brass satin nickel finished**

Pantalla polietileno rotomoldeado / Lámpara no incluida  
**Shade rotomolded polyethylene/Lamp not included**

2370/016 níquel satinado **satin nickel**

2371/016 níquel satinado **satin nickel**

2372/016 níquel satinado **satin nickel**

 E27 LED

CE  

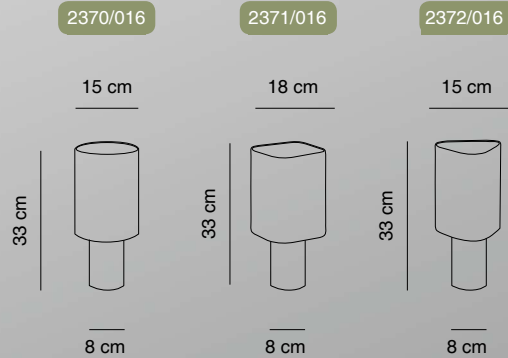

# Tiny

Design by Josep Novell & Josep Puig

Estructura latón acabado níquel  
**Structure brass satin nickel finished**

Con 4mt cable con funda de neopreno y clavija Schuko  
Structure **With 4mt neoprene cable with Schuko plug**

Lámpara no incluida  
**Lamp not included**

2375/016 níquel satinado **satin nickel**

2376/016 níquel satinado **satin nickel**

2377/016 níquel satinado **satin nickel**

E27 LED

CE  IP45 

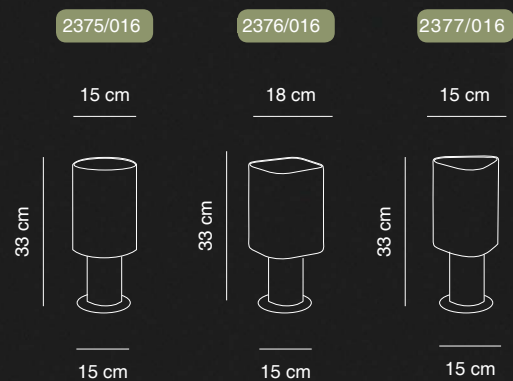



## Stone Out Led

Design by Josep Puig & Josep Novell

---

Pantalla polietileno rotomoldeado  
**Shade rotomolded polyethylene**



Lámpara incluida y no reemplazable  
**Lamp included and not replaceable**

Estructura acero inoxidable  
**Structure stainless steel**

---

9330/036LED blanco **white**  
LED Epistar 30W + 18W 4000lm 2700K

---

CE   

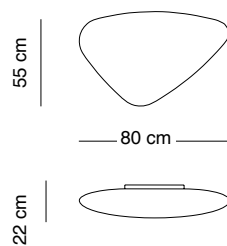







## Stone Out Led

Design by Josep Puig & Josep Novell

Pantalla polietileno rotomoldeado  
**Shade rotomolded polyethylene**

Estructura acero inoxidable pulido/aluminio  
**Structure polished stainless steel/aluminium**



Lámpara incluida y no reemplazable  
**Lamp included and not replaceable**

4 metros de cable con funda de neopreno y clavija Schuko  
**4 meters of neoprene cable with Schuko plug**

2300/036LED acero inoxidable pulido/aluminio anodizado  
**white polished stainless steel/anodized aluminium**

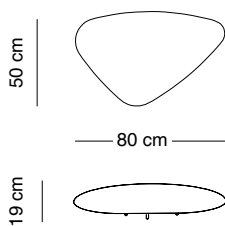
LED Epistar 30W + 18W 4000lm 2700K



CE   







ALMA light  
Barcelona





Alma Light se reserva el derecho de hacer cualquier modificación  
Catálogo realizado con papel ecológico, reciclelo, gracias

*Alma Light reserves the right to make any modification  
Catalogue printed with ecological paper, please recycle it*

Fotografía / **Photography**

Tribeca USB

Cristina Gual Busqué,  Racó19, Sant Vicenç de Montalt (Spain)

Andrea Elballe & Pau Larrea,  La Rania, Vidrà (Spain)

Tribeca, Star

 Cubiña, Barcelona (Spain)

 Curvas fotométricas disponibles en [www.almalight.com](http://www.almalight.com)  
*Photometric curves available on [www.almalight.com](http://www.almalight.com)*

Para acabados / colores distintos de los artículos catalogados, diseños especiales o formatos customizados, contactar con ALMA LIGHT  
*For finishes/colors different from the ones on this catalog, special designs or customized formats, please contact ALMA LIGHT*



# ALMALIGHT

---

**Oficina central y almacén**  
***Head office and warehouse***

Cristobal de Moura 195-197  
08019 Barcelona [Spain]

T [+34] 933 085 346  
F [+34] 933 084 386  
info@almalight.com

Follow us in Facebook  
Instagram & Printerest

**[www.almalight.com](http://www.almalight.com)**

---