

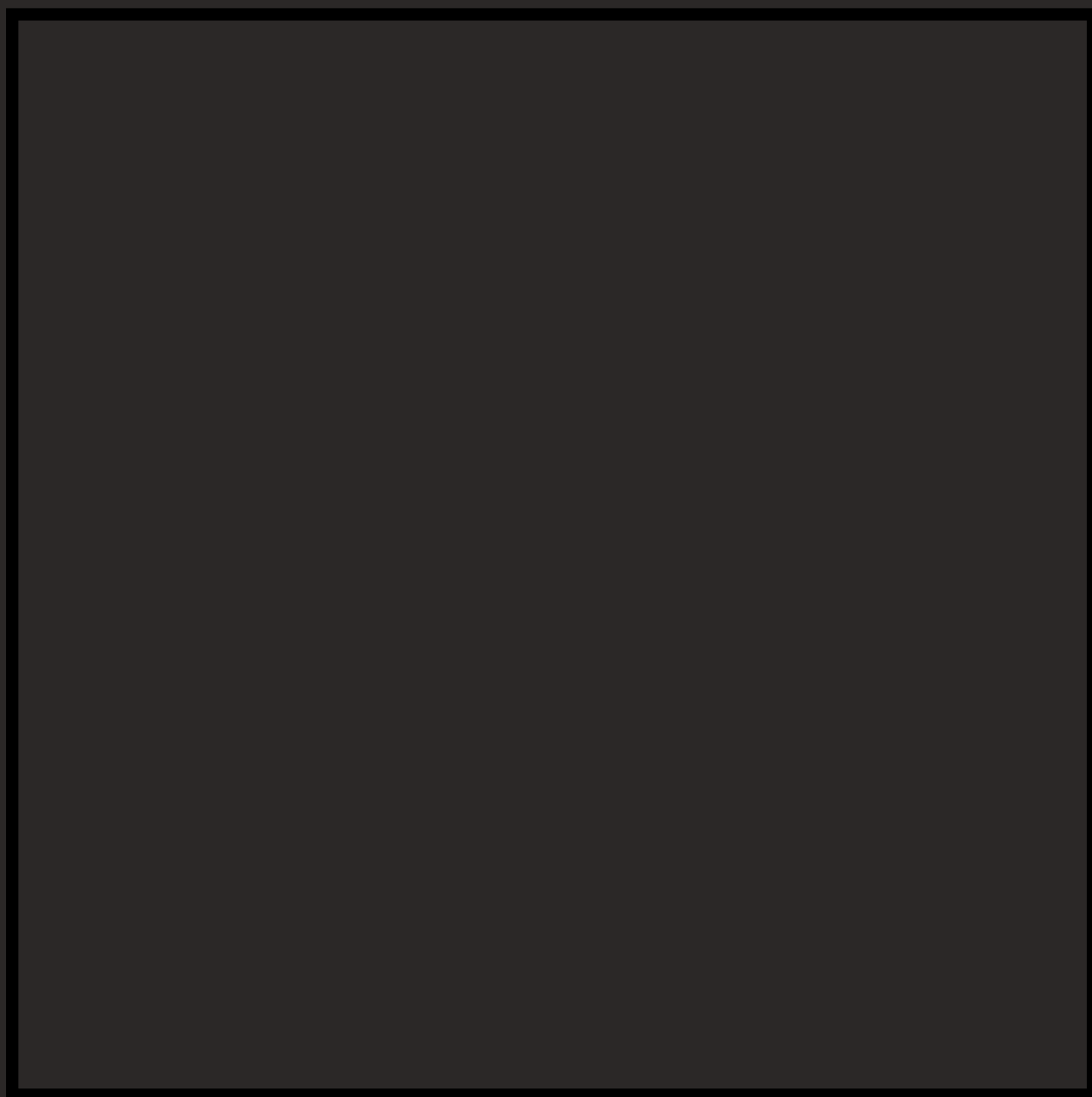

NEW COLLECTION
2019 //////////////////////////////////
////////////////////////////////////
OUTSIDE THE BOX



DE MAJO

DE MAJO



Una generazione dopo l'altra, il vetro come arte di famiglia

La de Majo ha origine nell'immediato dopoguerra ad opera di Guido de Majo, che dalla natia Napoli si trasferisce in laguna, e fonda, nel 1947, la sua prima fornace a Murano. Nonostante le piccole dimensioni degli esordi, sa rendersi da subito protagonista nella realtà vetraria muranese grazie ad un'oculata strategia aziendale sempre attenta alla qualità della produzione, sino a diventare in pochi anni una vera e propria industria.

Il forte impegno verso il miglioramento continuo, ha sempre permesso al marchio de Majo di cogliere i nuovi fermenti che investivano l'industria del vetro. Quando negli anni Sessanta il design è entrato a far parte dello scenario produttivo, de Majo è stata tra le prime aziende ad investire nel settore, affiancando alle creazioni di alto artigianato tradizionale un'accurata produzione seriale, ed allargando perciò sensibilmente la propria fascia di mercato. Sin da allora, è stato dato spazio a giovani designers la cui creatività ha potuto liberamente esprimersi per giungere al miglior risultato ottenibile: vale a dire un prodotto che, per quanto serializzato, mantenesse sempre un'anima, una coerenza progettuale in equilibrio perfetto tra esigenze estetiche ed esigenze funzionali.

L'attenzione e cura estrema nella lavorazione del vetro, per de Majo è storicamente andata di pari passo con le necessità di sicurezza sul luogo di lavoro e di rispetto per l'ambiente.

Oggi, l'azienda mantiene viva ed evolve l'antica tradizione ricercando sempre nuovi linguaggi espressivi e offrendo al pubblico un'ampia panoramica sulle ultime tendenze del design: esercizi di stile pensati per la sensibilità di chi, anche nell'ambito del gusto contemporaneo, sa riconoscere gli autentici valori della qualità e dell'eleganza.

Generation after generation, glass as family art

de Majo was first established at the end of the second world war by Guido de Majo, who, having left his native Naples, moved to the Lagoon, and in 1947 founded his first glassworks on the island of Murano. Although a small business concern at the beginning he knew how to transform it into an important reality in the world of Murano glass thanks to a company strategy built on quality production techniques turning this company, in just a few years, into a leading industrial enterprise.

This commitment, focalised on ongoing improvement, allowed de Majo to deal with new the forms of pressure which were sweeping across the glass industry. In the 70's design became an important element in production and de Majo was one of the first companies to invest in this concept and introduced alongside the traditional high-quality crafted products, a standardised range expanding its own market considerably. Since that point in time de Majo has always given young designers the right amount of freedom of creativity to achieve to best results possible which simply translates into a product, however "standard" with its own personality, and the perfect balance between lighting efficiency and appeal.

The meticulous care to detail and to production techniques for de Majo has always embraced the need for guaranteeing safety in the workplace and respect for the environment.

Today, this company maintains the early traditions and at the same time strives for new style appeal offering customers a wide selection of current design trends for who with a taste for the contemporary appreciates authentic quality and elegance.



Indice - Index

NEWS

Arcade	<i>pag_6</i>
Astro	<i>pag_10</i>
Biro	<i>pag_14</i>
Ghost	<i>pag_20</i>
Knot	<i>pag_26</i>
I Dischi	<i>pag_30</i>
Impero	<i>pag_34</i>

RESTYLING

Boa	<i>pag_38</i>
Cannettata	<i>pag_42</i>
Diaphanès	<i>pag_46</i>
Dome	<i>pag_52</i>
Memory	<i>pag_56</i>
Otto x Otto	<i>pag_60</i>
Peroni	<i>pag_64</i>
<Tag>	<i>pag_68</i>
Tommy	<i>pag_72</i>
2400-2400 Shade	<i>pag_76</i>

Indice - Index

News



Arcade
S
6



Astro
S
10



Biro
S
14



Ghost
S
20



Knot
A, S
26



I Dischi
P
30



Impero
K
34

Restyling



Boa
S
38



Cannettata
A, P, S
42



Diaphanès
A, T
46



Dome
A, P, S
52



Memory
A, S
56

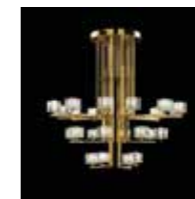

Otto x Otto
K
60



Peroni
A, S
64



<Tag>
S
68



Tommy
S
72



2400_2400 Shade
A, K
76



ARCADE

Design by Francesco de Majo



SHADE
cotone naturale
polimerizzato
con vinilici
natural cotton
backing with
vinyl coating



STRUCTURE
oro opaco
matt gold



WOOD
rovere naturale
natural oak





NOTA : OPZIONI FINITURE CUSTOM DISPONIBILI
 NOTE : CUSTOM FINISHES OPTIONS AVAILABLE

NOTA : ALTRE CONFIGURAZIONI CUSTOM DISPONIBILI
 NOTE : OTHER CUSTOM CONFIGURATIONS AVAILABLE



ROSONE ORO OPACO
 CAVO TESSILE LINO MARRONE

MATT GOLD CANOPY
 BROWN LINEN TEXTILE CABLE

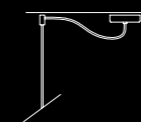
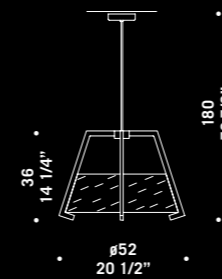

KIT DECENTRAMENTO
 DECENTRALIZATION KIT

ARCADE S
 1xMAX 18W E27 LED
 LED light bulb





ASTRO

Design by Lucio de Majo

GLASS
nero fumo -
cristallo oro
smoke black -
clear with gold



STRUCTURE
oro opaco
matt gold



nero opaco
matt black





NOTA : OPZIONI FINITURE CUSTOM DISPONIBILI
 NOTE : CUSTOM FINISHES OPTIONS AVAILABLE

NOTA : ALTRE CONFIGURAZIONI CUSTOM DISPONIBILI
 NOTE : OTHER CUSTOM CONFIGURATIONS AVAILABLE



ROSONE ORO OPACO
 CAVO TESSILE NERO

MATT GOLD CANOPY
 BLACK TEXTILE CABLE



ROSONE NERO OPACO
 CAVO TESSILE NERO

MATT BLACK CANOPY
 BLACK TEXTILE CABLE

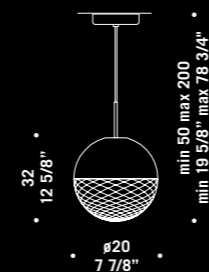

ASTRO S
 1xMAX 10W G9 LED
 LED light bulb

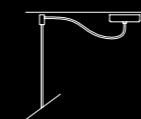

KIT DECENTRAMENTO
 DECENTRALIZATION KIT



BIRO

Design by Francesco de Majo

GLASS
cristallo
clear



STRUCTURE
oro opaco
matt gold



nero opaco
matt black



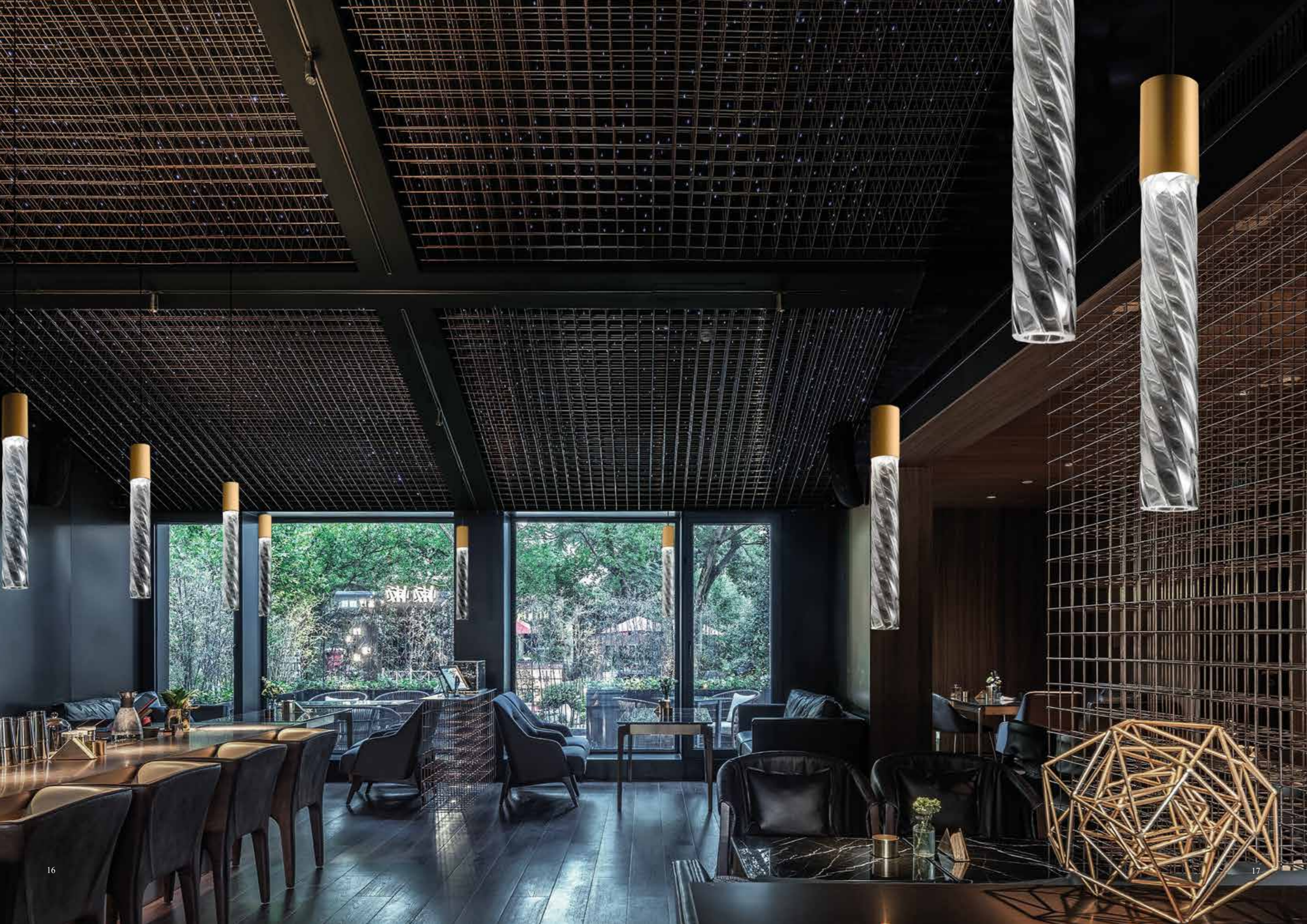



NOTA : OPZIONI FINITURE CUSTOM DISPONIBILI
 NOTE : CUSTOM FINISHES OPTIONS AVAILABLE

NOTA : ALTRE CONFIGURAZIONI CUSTOM DISPONIBILI
 NOTE : OTHER CUSTOM CONFIGURATIONS AVAILABLE





ROSONE ORO OPACO
CAVO TESSILE NERO
MATT GOLD CANOPY
BLACK TEXTILE CABLE

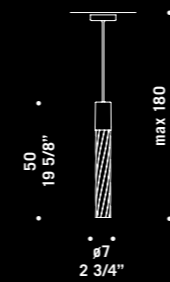

ROSONE NERO OPACO
CAVO TESSILE NERO
MATT BLACK CANOPY
BLACK TEXTILE CABLE



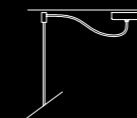

BIRO S
 1xMAX 10W GU10 LED  
 LED light bulb 



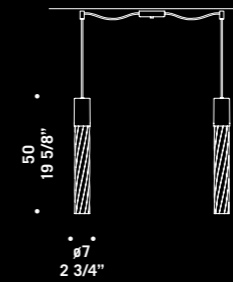

KIT DECENTRAMENTO
DECENTRALIZATION KIT

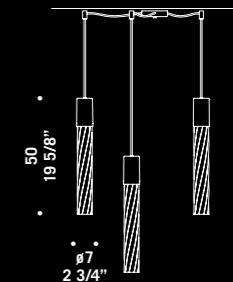

BIRO S2D
 2xMAX 10W GU10 LED  
 LED light bulb 



BIRO S3D
 3xMAX 10W GU10 LED  
 LED light bulb 



GHOST

Design by Giovanni Barbato

SPHERE

lattimo
milkwhite



GLASS

cristallo
clear glass



blu corallo
coral blue



ciclamo
cyclamen



STRUCTURE

ottone spazzolato
brushed brass







NOTA : OPZIONI FINITURE CUSTOM DISPONIBILI
 NOTE : CUSTOM FINISHES OPTIONS AVAILABLE

NOTA : ALTRE CONFIGURAZIONI CUSTOM DISPONIBILI
 NOTE : OTHER CUSTOM CONFIGURATIONS AVAILABLE



ROSONE OTTONE SPAZZOLATO
 CAVO TESSILE AVORIO

BRUSHED BRASS CANOPY
 IVORY TEXTILE CABLE

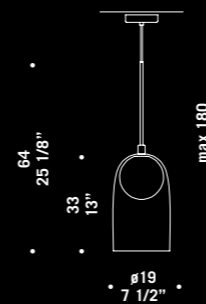

GHOST S19
 9W 1400lm
 LED 3000K

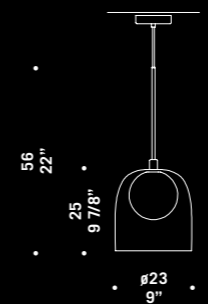

GHOST S23
 9W 1400lm
 LED 3000K

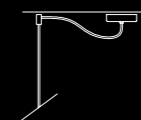

KIT DECENTRAMENTO
DECENTRALIZATION KIT



KNOT

Design by Francesco Dei Rossi



GLASS
cristallo -lattimo
clear-milkwhite



STRUCTURE
cromo
chrome





NOTA : OPZIONI FINITURE CUSTOM DISPONIBILI
 NOTE : CUSTOM FINISHES OPTIONS AVAILABLE

NOTA : ALTRE CONFIGURAZIONI CUSTOM DISPONIBILI
 NOTE : OTHER CUSTOM CONFIGURATIONS AVAILABLE



COMPOSIZIONI CON I SEGUENTI ELEMENTI
 COMPOSITIONS WITH THE FOLLOWING ELEMENTS

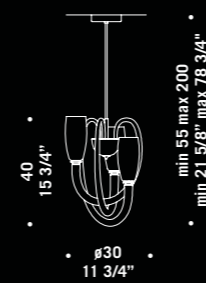
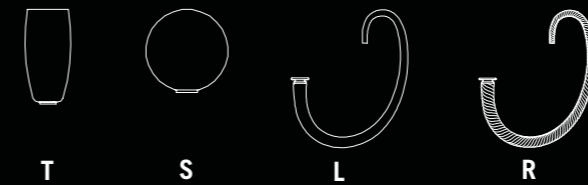

KNOT S3
 3xG9 LED
 LED light bulb
 3xMAX 60W G9

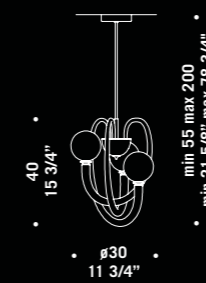

KNOT S3
 3xG9 LED
 LED light bulb
 3xMAX 60W G9

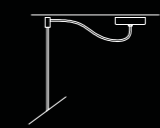

KIT DECENTRAMENTO
 DECENTRALIZATION KIT

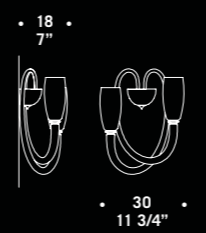

KNOT A2
 2xG9 LED
 LED light bulb
 2xMAX 60W G9

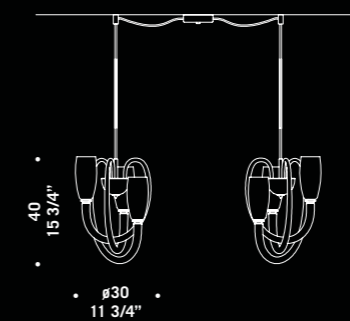

KNOT S3D2
 6xG9 LED
 LED light bulb
 6xMAX 60W G9

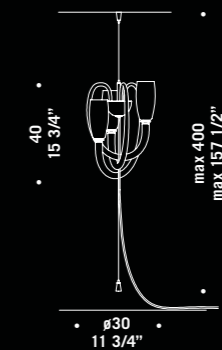

KNOT S3V
 3xG9 LED
 LED light bulb
 3xMAX 60W G9





I DISCHI

Design by Ufficio Stile de Majo



GLASS
cristallo
clear



STRUCTURE
ottone
brass





NOTA : OPZIONI FINITURE CUSTOM DISPONIBILI
 NOTE : CUSTOM FINISHES OPTIONS AVAILABLE

NOTA : ALTRE CONFIGURAZIONI CUSTOM DISPONIBILI
 NOTE : OTHER CUSTOM CONFIGURATIONS AVAILABLE

ESEMPIO SISTEMA MODULARE
EXAMPLE MODULAR SYSTEM

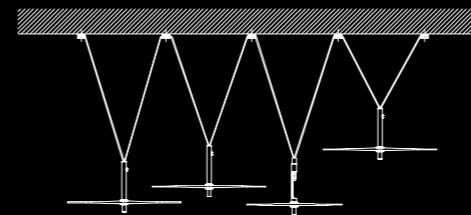
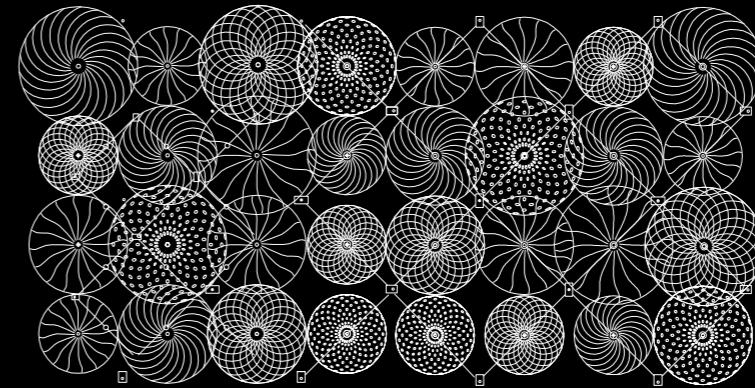

64
25 1/8"

90
35 3/8"

90
35 3/8"

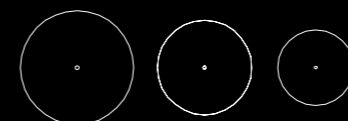
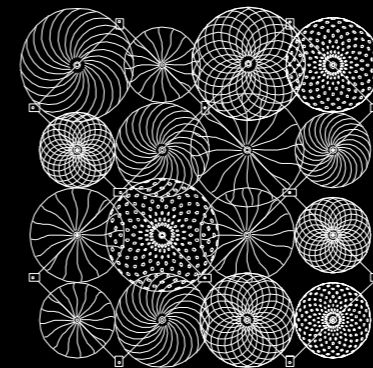

• ø30 11 3/4" • • ø25 9 7/8" • • ø20 7 7/8" •

I DISCHI P
 6x1,2W 12V G4 LED
 6xMAX 10W 12V G4





IMPERO

Design by Ufficio Stile de Majo



GLASS
cristallo antico
antique clear



STRUCTURE
cromo
chrome





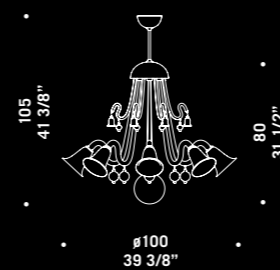

NOTA : OPZIONI FINITURE CUSTOM DISPONIBILI
NOTE : CUSTOM FINISHES OPTIONS AVAILABLE

NOTA : ALTRE CONFIGURAZIONI CUSTOM DISPONIBILI
NOTE : OTHER CUSTOM CONFIGURATIONS AVAILABLE



IMPERO K9 
9xMAX 8W E14 LED 
LED light bulb 



BOA

Design by Oriano Favaretto

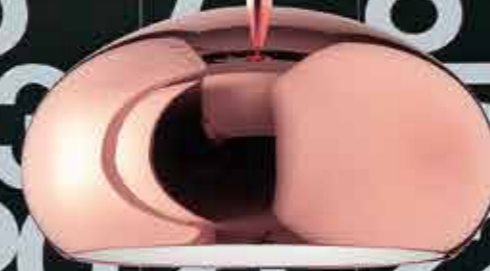
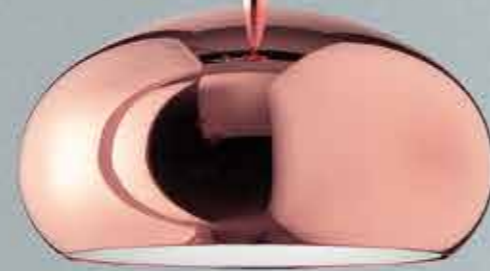

GLASS
cristallo sabbato
frosted



STRUCTURE
cromo
chrome



ciclamino perlato
pearly cyclamen



oro opaco
matt gold



rame lucido
polish copper

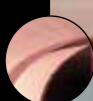



NOTA : OPZIONI FINITURE CUSTOM DISPONIBILI
 NOTE : CUSTOM FINISHES OPTIONS AVAILABLE

NOTA : ALTRE CONFIGURAZIONI CUSTOM DISPONIBILI
 NOTE : OTHER CUSTOM CONFIGURATIONS AVAILABLE



ROSONE ORO OPACO
 CAVO TESSILE AVORIO

MATT GOLD CANOPY
 IVORY TEXTILE CABLE



ROSONE CICLAMINO PERLATO
 CAVO TESSILE AVORIO

PEARLED CYCLAMEN CANOPY
 IVORY TEXTILE CABLE



ROSONE CROMO
 CAVO TESSILE NERO

CHROME CANOPY
 BLACK TEXTILE CABLE



ROSONE RAME LUCIDO
 CAVO RAME BICOLOR

POLISH COPPER CANOPY
 BICOLOR COPPER CABLE



BOA S ED
 9W 900lm
 LED 2700K CRI90
 alimentatore dimmerabile
 dimmable ballast



KIT DECENTRAMENTO
DECENTRALIZATION KIT

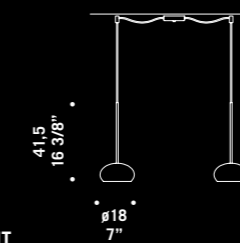

BOA S2D ED
 2x9W 900lm
 LED 2700K CRI90
 alimentatore dimmerabile
 dimmable ballast

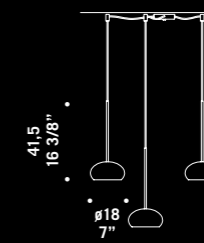

BOA S3D ED
 3x9W 900lm
 LED 2700K CRI90
 alimentatore dimmerabile
 dimmable ballast



CANNETTATA

Design by Massimo Iosa Ghini



GLASS
fumé



STRUCTURE
oro opaco
matt gold





NOTA : OPZIONI FINITURE CUSTOM DISPONIBILI
 NOTE : CUSTOM FINISHES OPTIONS AVAILABLE

NOTA : ALTRE CONFIGURAZIONI CUSTOM DISPONIBILI
 NOTE : OTHER CUSTOM CONFIGURATIONS AVAILABLE



ROSONE ORO OPACO
 CAVO TESSILE NERO

MATT GOLD CANOPY
 BLACK TEXTILE CABLE

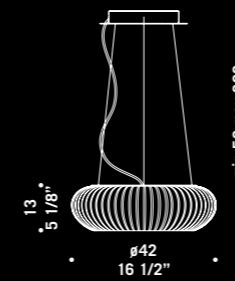

CANNETTATA S42 ED
 25W 2500lm
 LED 2700K CRI90
 alimentatore dimmerabile
dimnable ballast

CANNETTATA S42 HALOGEN
 1 x 120W R7s 78 mm
 1 x 7W R7s LED

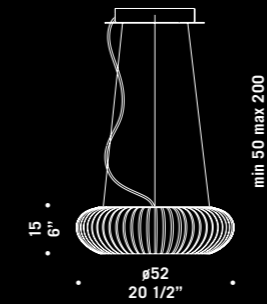

CANNETTATA S52 ED
 42W 4200lm
 LED 2700K CRI90
 alimentatore dimmerabile
dimnable ballast

CANNETTATA S52 HALOGEN
 1 x 160W R7s 118 mm
 1 x 15W R7s LED

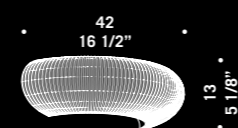

CANNETTATA A42
 16W 1300lm
 LED 2700K



CANNETTATA P42 ED
 25W 2500lm
 LED 2700K CRI90
 alimentatore dimmerabile
dimnable ballast

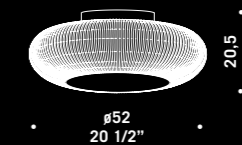

CANNETTATA P52 ED
 42W 4200lm
 LED 2700K CRI90
 alimentatore dimmerabile
dimnable ballast



DIAPHANÈS

Design by Valerio Cometti

GLASS
cristallo
clear glass

STRUCTURE
bianco lucido
polished white







NOTA : OPZIONI FINITURE CUSTOM DISPONIBILI
 NOTE : CUSTOM FINISHES OPTIONS AVAILABLE

NOTA : ALTRE CONFIGURAZIONI CUSTOM DISPONIBILI
 NOTE : OTHER CUSTOM CONFIGURATIONS AVAILABLE

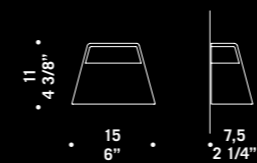

DIAPHANÈS A15
 1xMAX 3,5W G9 LED
 LED light bulb

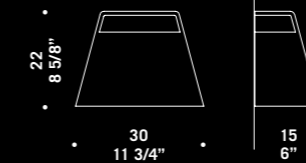

DIAPHANÈS A30 ED
 13W 1300lm
 LED 2700K
 alimentatore dimmerabile
 dimmable ballast

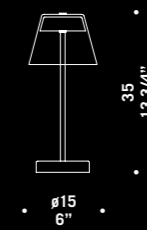

DIAPHANÈS L15
 1,6W 150lm
 LED 3000K
 touch dimmer
 ricaricabile
 rechargeable

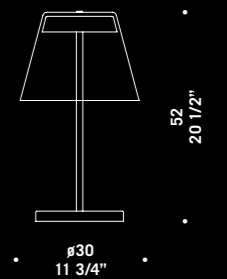

DIAPHANÈS T30
 18W 1800lm
 LED 2700K
 push dimmer





DOME

Design by Chiaramonte Marin

GLASS
cristallo
clear



tortora
turtle-dove gray



STRUCTURE
bianco opaco
matt white



SHADE
avorio
ivory



grigio
grey





NOTA : OPZIONI FINITURE CUSTOM DISPONIBILI
NOTE : CUSTOM FINISHES OPTIONS AVAILABLE

NOTA : ALTRE CONFIGURAZIONI CUSTOM DISPONIBILI
NOTE : OTHER CUSTOM CONFIGURATIONS AVAILABLE



ROSONE BIANCO OPACO
CAVO TESSILE LINO AVORIO
VETRO TORTORA
PARALUME AVORIO

MATT WHITE CANOPY
IVORY LINEN TEXTILE CABLE
TURTLE-DOVE GRAY DIFFUSER
TISSUE IVORY SHADE

ROSONE BIANCO OPACO
CAVO TESSILE LINO GRIGIO
VETRO CRISTALLO
PARALUME GRIGIO

MATT WHITE CANOPY
GREY LINEN TEXTILE CABLE
CLEAR DIFFUSER
TISSUE GREY SHADE

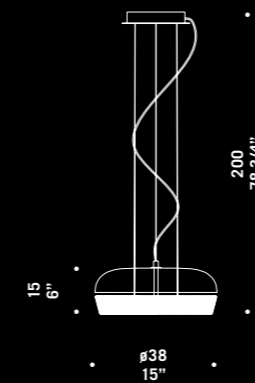

DOME S38 ED
25W 2500lm
LED 2700K CRI90
alimentatore dimmerabile
dimnable ballast

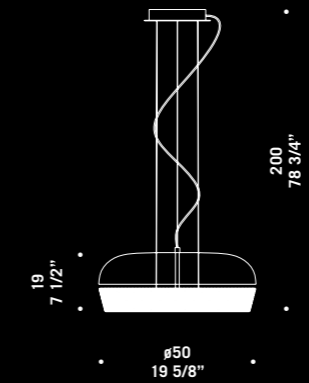

DOME S50 ED
35W 3500lm
LED 2700K CRI90
alimentatore dimmerabile
dimnable ballast

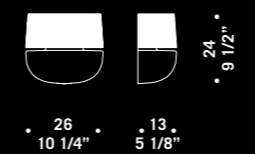

DOME A26
12,5W 1260lm
LED 2700K CRI90

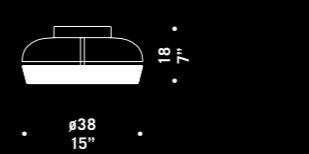

DOME P38 ED
25W 2500lm
LED 2700K CRI90
alimentatore dimmerabile
dimnable ballast

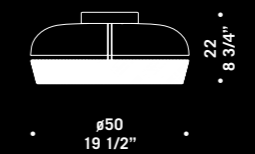

DOME P50 ED
35W 3500lm
LED 2700K CRI90
alimentatore dimmerabile
dimnable ballast



MEMORY

Design by Lucio de Majo



GLASS
cristallo
clear



bianco satinato
satinated white



fumè



STRUCTURE
ottone opaco
matt brass





NOTA : OPZIONI FINITURE CUSTOM DISPONIBILI
NOTE : CUSTOM FINISHES OPTIONS AVAILABLE

NOTA : ALTRE CONFIGURAZIONI CUSTOM DISPONIBILI
NOTE : OTHER CUSTOM CONFIGURATIONS AVAILABLE



ROSONE OTTONE OPACO
CAVO TESSILE NERO

MATT BRASS CANOPY
BLACK TEXTILE CABLE

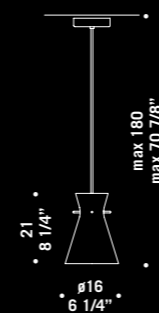

MEMORY S1P
1xMAX 18W E27 LED
LED light bulb

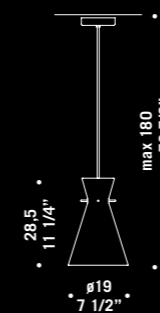

MEMORY S1G
1xMAX 18W E27 LED
LED light bulb

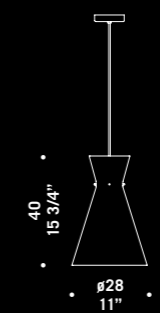

MEMORY SL
1xMAX 18W E27 LED
LED light bulb

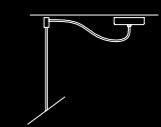

KIT DECENTRAMENTO
DECENTRALIZATION KIT

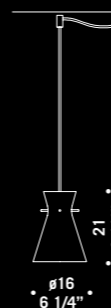

MEMORY S2PD
2xMAX 18W E27 LED
LED light bulb
MEMORY S2GD
2xMAX 18W E27 LED
LED light bulb

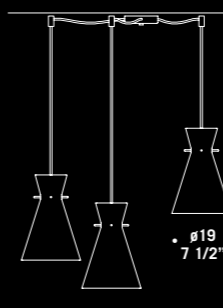

MEMORY S3GD
3xMAX 18W E27 LED
LED light bulb
MEMORY S3PD
3xMAX 18W E27 LED
LED light bulb

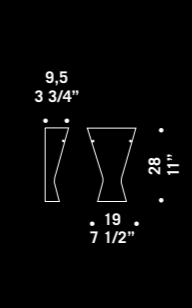

SOLO BIANCO SATINATO
ONLY SATINED WHITE
MEMORY A1
1x120W R7s 78 mm





OTTO X OTTO

Design by Francesco Dei Rossi



GLASS
cristallo extrachiaro
extraclear



STRUCTURE
ottone dorato
opaco
matt golden brass



ottone dorato
lucido
polished golden
brass





NOTA : OPZIONI FINITURE CUSTOM DISPONIBILI
 NOTE : CUSTOM FINISHES OPTIONS AVAILABLE

NOTA : ALTRE CONFIGURAZIONI CUSTOM DISPONIBILI
 NOTE : OTHER CUSTOM CONFIGURATIONS AVAILABLE

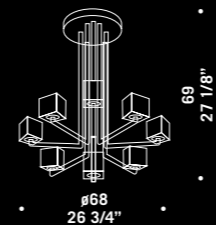

OTTO X OTTO K8
 8 x G9 LED
 LED light bulb
 8xMAX 60W G9

doppia accensione
 double switch

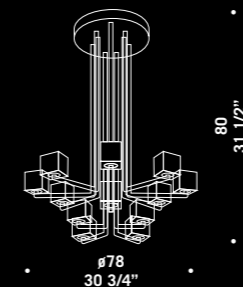

OTTO X OTTO K4+8
 12 x G9 LED
 LED light bulb
 12xMAX 60W G9

doppia accensione
 double switch

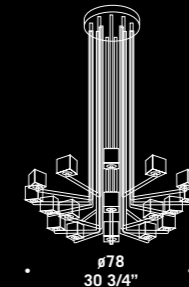

OTTO X OTTO K8+8
 16 x G9 LED
 LED light bulb
 16xMAX 60W G9

doppia accensione
 double switch

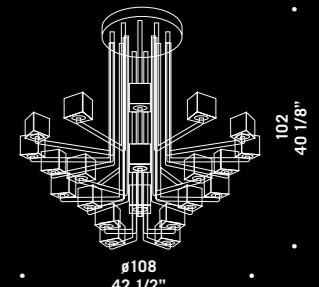

OTTO X OTTO K4+8+12
 24 x G9 LED
 LED light bulb
 24xMAX 60W G9

doppia accensione
 double switch

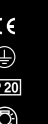



PERONI

Design by Ufficio Stile de Majo



GLASS
cristallo
clear



bianco satinato
satinated white



fumè



STRUCTURE
ottone opaco
matt brass





NOTA : OPZIONI FINITURE CUSTOM DISPONIBILI
 NOTE : CUSTOM FINISHES OPTIONS AVAILABLE

NOTA : ALTRE CONFIGURAZIONI CUSTOM DISPONIBILI
 NOTE : OTHER CUSTOM CONFIGURATIONS AVAILABLE



ROSONE OTTONE OPACO
 CAVO TESSILE NERO

MATT BRASS CANOPY
 BLACK TEXTILE CABLE

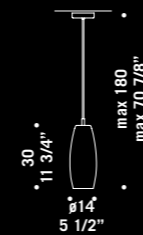

PERONI S14
 1xMAX 18W E27 LED
 LED light bulb

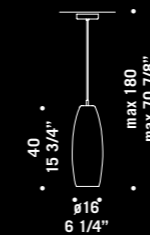

PERONI S16
 1xMAX 18W E27 LED
 LED light bulb

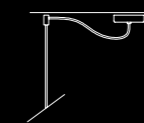

KIT DECENTRAMENTO
 DECENTRALIZATION KIT

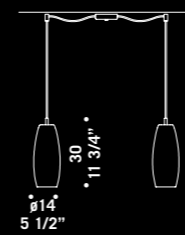

PERONI S14D2
 2xMAX 18W E27 LED
 LED light bulb
PERONI S16D2
 2xMAX 18W E27 LED
 LED light bulb

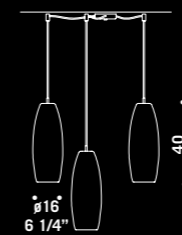

PERONI S16D3
 3xMAX 18W E27 LED
 LED light bulb
PERONI S14D3
 3xMAX 18W E27 LED
 LED light bulb

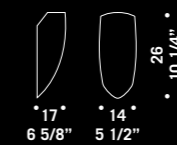

PERONI A1
 1xMAX 18W E27 LED
 LED light bulb





<TAG>

Design by Francesco de Majo



GLASS
fumè



WOOD
rovere naturale
natural oak



STRUCTURE
oro opaco
matt gold





NOTA : OPZIONI FINITURE CUSTOM DISPONIBILI
 NOTE : CUSTOM FINISHES OPTIONS AVAILABLE

NOTA : ALTRE CONFIGURAZIONI CUSTOM DISPONIBILI
 NOTE : OTHER CUSTOM CONFIGURATIONS AVAILABLE



ROSONE ORO OPACO
 CAVO TESSILE NERO

MATT GOLD CANOPY
 BLACK TEXTILE CABLE

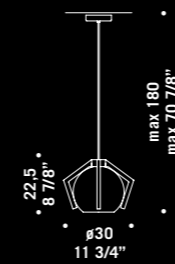

<TAG> S
 1xMAX 18W E27 LED
 LED light bulb



KIT DECENTRAMENTO
 DECENTRALIZATION KIT

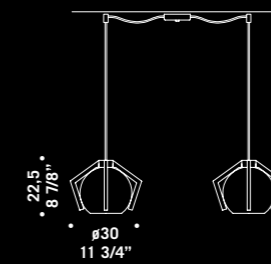

<TAG> S2D
 2xMAX 18W E27 LED
 LED light bulb

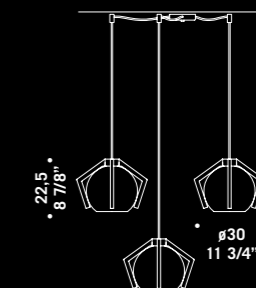

<TAG> S3D
 3xMAX 18W E27 LED
 LED light bulb





TOMMY

Design by Ufficio Stile de Majo



GLASS
cristallo
clear



STRUCTURE
ottone opaco
matt brass



rame lucido
polish copper





NOTA : OPZIONI FINITURE CUSTOM DISPONIBILI
 NOTE : CUSTOM FINISHES OPTIONS AVAILABLE

NOTA : ALTRE CONFIGURAZIONI CUSTOM DISPONIBILI
 NOTE : OTHER CUSTOM CONFIGURATIONS AVAILABLE



ROSONE OTTONE OPACO
CAVO TESSILE NERO
MATT BRASS CANOPY
BLACK TEXTILE CABLE



ROSONE RAME LUCIDO
CAVO RAME BICOLOR
POLISH COPPER CANOPY
BICOLOR COPPER CABLE

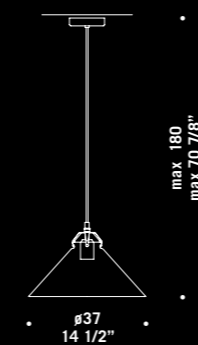

TOMMY S10
 1xMAX 18W E27 LED
 LED light bulb

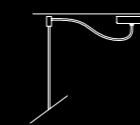

KIT DECENTRAMENTO
DECENTRALIZATION KIT



2400

2400 SHADE



GLASS
cristallo
clear



ambra
amber



STRUCTURE
cromo
chrome



oro
gold





NOTA : OPZIONI FINITURE CUSTOM DISPONIBILI
 NOTE : CUSTOM FINISHES OPTIONS AVAILABLE

NOTA : ALTRE CONFIGURAZIONI CUSTOM DISPONIBILI
 NOTE : OTHER CUSTOM CONFIGURATIONS AVAILABLE

SERIE 2400 - 2400 SHADE DISPONIBILE CON GOCCE NEI COLORI CRISTALLO E AMBRA.
 SERIE 2400 - 2400 SHADE DISPONIBILE CON GOCCE NEI COLORI CRISTALLO E AMBRA.



CRISTALLO
 CLEAR GLASS



AMBRA
 AMBER GLASS

2400



CONFIGURAZIONI
 CONFIGURATION

2400 A1
 2400 A2
 2400 A2+1
 2400 A3
 2400 A6

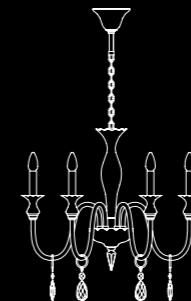

CONFIGURAZIONI
 CONFIGURATION

2400 K3
 2400 K3+3
 2400 K5
 2400 K6
 2400 K6+3
 2400 K8
 2400 K8+4
 2400 K10
 2400 K10+5
 2400 K12
 2400 K12+6
 2400 K16+8
 2400 K24+12
 2400 K24+12+6

2400 SHADE



CONFIGURAZIONI
 CONFIGURATION

2400 A1 SHADE
 2400 A2 SHADE
 2400 A2+1 SHADE
 2400 A3 SHADE
 2400 A6 SHADE



CONFIGURAZIONI
 CONFIGURATION

2400 K3 SHADE
 2400 K3+3 SHADE
 2400 K5 SHADE
 2400 K6 SHADE
 2400 K6+3 SHADE
 2400 K8 SHADE
 2400 K8+4 SHADE
 2400 K10 SHADE
 2400 K10+5 SHADE
 2400 K12 SHADE
 2400 K12+6 SHADE
 2400 K16+8 SHADE
 2400 K24+12 SHADE
 2400 K24+12+6 SHADE

SIMBOLOGIA - SYMBOLS



La marcatura "CE" voluta dalla Comunità Europea con direttiva 93/68/CEE attesta la conformità dell'apparecchio ai requisiti richiesti dalle norme tecniche.

The "CE" mark required by the European Community with the 93/68/CEE directive states that the luminaire complies with the European technical requirements.



Apparecchio dotato di protezione contro la scossa elettrica basata sul fatto che in ogni punto dell'apparecchio la tensione di alimentazione e/o di funzionamento è inferiore a 50V.

The protection against electric shocks of this luminaire is achieved by every component having a start/functioning voltage of less than 50VA.



Apparecchio non predisposto per il montaggio diretto su superfici normalmente infiammabili. Luminaire not suitable for direct mounting onto normally inflammable surfaces.



Indica che si possono installare delle lampadine a basso consumo di energia (tipo fluorescenti) This indicates you can use energy saving lamps (fluorescent lamps).



Apparecchio dotato di involucro protetto contro la penetrazione di corpi solidi superiori a 12 mm e non protetto contro la penetrazione di liquidi.

The enclosure of this luminaire is protected against solid objects up to than 12 mm, no special protection provided against penetration of water.



Apparecchio dotato di involucro protetto contro la penetrazione di corpi solidi con dimensioni superiori a 2,5 mm e non protetto contro la penetrazione di liquidi.

The enclosure of this luminaire is protected against solid objects up to than 2,5 mm, no special protection provided against penetration of water.



Apparecchio dotato di involucro protetto contro la penetrazione di corpi solidi con dimensioni superiori a 1 mm e non protetto contro la penetrazione di liquidi.

The enclosure of this luminaire is protected against solid objects up to than 1 mm, no special protection provided against penetration of water.



Apparecchio totalmente protetto contro la polvere e contro le ondate di acqua marina. Enclosure rated as dust tight and protected against heavy seas or powerful jets of water.



Apparecchio nel quale la protezione contro la scossa elettrica si basa oltre che dall'isolamento principale anche dalla connessione delle parti conduttrici accessibili ad un conduttore di protezione dell'impianto elettrico fisso.

Luminaire in which protection against electric shock does not rely on basic insulation only, but which are provided for the connection of accessible conductive parts to the protective conductor in the fixed wiring of the installation.



Apparecchio da dotare di lampadine tipo alogene autoprotette (a bassa pressione). This luminaire requires self-shielded tungsten halogen lamps (low pressure).



Apparecchio dotato di protezione contro la scossa elettrica basata sull'isolamento fondamentale e su misure supplementari quali il doppio isolamento rinforzato.

The protection against electrical shocks of this luminaire is achieved by simple insulation and some other devices such as double insulation or reinforced insulation. There is no earth cable provided.



American Disability Act



Certificazione di conformità di prodotto che attesta l'idoneità ai requisiti essenziali di sicurezza ad esso applicabili richiesti dai paesi dell'Unione doganale di Russia.

Certification of product conformity attesting suitability to the essential and applicable safety requirements in the countries of the Customs Union in Russia.

Ferme restando le caratteristiche basilari del prodotto, D.M. LUCE S.r.l. si riserva di apportare modifiche in ogni momento al solo scopo di miglioramento.

While maintaining the basic characteristics of the product, D.M. LUCE S.r.l. reserves the right to make modifications at any time with the sole aim of improvement.

Simbologia Symbols

Ø: diametro diameter

l: larghezza width

h: altezza height

s: sporgenza protusion

Etichette energetiche Energy labels

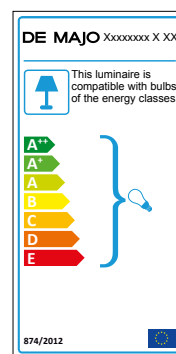
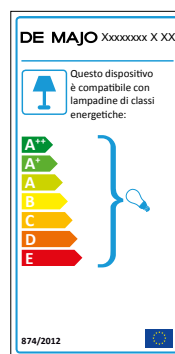

KNOT
I DISCHI
IMPERO
CANNETTATA HALO
OTTO X OTTO
ARCADE
ASTRO
BIRO
MEMORY
PERONI
<TAG>
TOMMY
2400
2400 SHADE

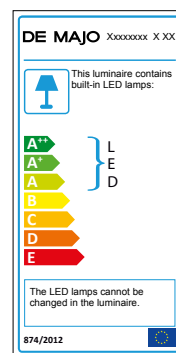
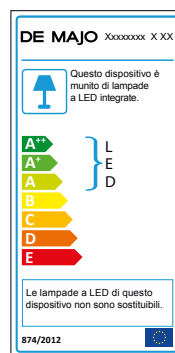

GHOST
BOA
CANNETTATA LED
DIAPHANES
DOME

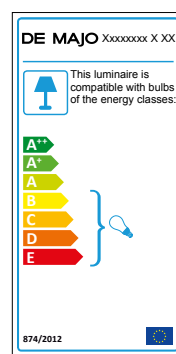
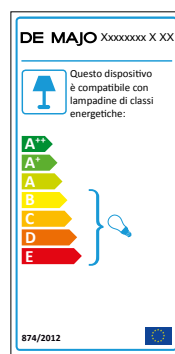

MEMORY A1



D.M. LUCE S.R.L.

Via Galileo Galilei, 34 - 30035 Mirano (VE)
Tel +39 041 57 29 653 - Fax +39 041 57 02 533
demajo@demajomurano.com
EXPORT DEPARTMENT
Tel +39 041 57 29 654 - Fax +39 041 57 29 647
export@demajomurano.com

www.demajoilluminazione.com

